

STRUCTURE Silicon Monolithic Integrated Circuit

PRODUCT NAME Multi-Channel Power IC

TYPE **BD8165MUV**

FEATURES

- Built-in 5-channel outputs for TFT-LCD Display
- Built-in VCOM AMP

●ABSOLUTE MAXIMUM RATINGS (Ta=25°C)

PARAMETER	SYMBOL	LIMITS	UNIT
Supply Voltage 1	VCC,PVCC2,3	15	V
Supply Voltage 2	LDVCC1	7	V
Supply Voltage 3	HVCC	20	V
SW1 Voltage	VSW1	22	V
Junction Temperature	Tjmax	150	°C
Power Dissipation	Pd	4826*1	mW
Operating Temperature Range	Topr	-40~105	°C
Storage Temperature Range	Tstg	-55~150	°C

*1 Decreased in done 38.6mW/°C for operating above Ta≥25°C,
mounted on 70×70×1.6mm 4 layer Glass-epoxy PCB. (back foil 70.0mm×70.0mm)

●OPERATING CONDITIONS (Ta=-40°C~+105°C)

Parameter	Symbol	MIN	MAX	Unit
Supply Voltage 1	VCC,PVCC2,3	4.2	14	V
Supply Voltage 2	LDVCC1	-	5.5	V
Supply Voltage 3	HVCC	6	18	V
SW1 Voltage	VSW1	-	18	V

Status of this document

The Japanese version of this document is the formal specification.

A customer may use this translation version only for a reference to help reading the formal version.

If there are any differences in translation version of this document, formal version takes priority.

● ELECTRICAL CHARACTERISTICS (Unless otherwise specified, Ta=25°C, VCC=12V, HVCC=15V)

Parameter	Symbol	Limit			Unit	Condition
		MIN	TYP	MAX		
【DC/DC BLOCK】						
Feed Back Voltage 1	VFB1	1.230	1.250	1.270	V	
Feed Back Voltage 2	VFB2	1.225	1.250	1.275	V	
Feed Back Voltage 3	VFB3	0.882	0.900	0.918	V	
FB Input Bias Current	IFB	-1.2	0.1	1.2	uA	
COMP Source Current	ICSO	15	40	65	uA	
COMP Sink Current	ICSI	-65	-40	-15	uA	
MAX Duty	MDT	80	90	-	%	
【LD01, LD03 BLOCK】						
LDO Feed Back Voltage	LDFB	1.231	1.25	1.269	V	
Drop Voltage 1	DPLD1	-	0.3	1.0	V	LDFB1=1.0V, Io=500mA
Drop Voltage H	DPLDH	-	0.4	0.9	V	LDFB_H=1.0V, Io=100mA
【Charge Pump BLOCK】						
Feed Back Voltage	CPFEB	1.225	1.25	1.275	V	
Drop Voltage 1	DPCPP	0.14	0.35	0.78	V	Io=100mA
Drop Voltage 2	DPCPN	0.28	0.7	1.55	V	Io=100mA
【Operational Amplifier BLOCK】						
Input Offset Voltage	VOFF	-15	0	15	mV	
VCOM Output Current	ICOM	60	150	-	mA	
Load Regulation	ΔV_o	-15	1	15	mV	Io=+1mA~-1mA
Maximum Output Voltage	VoH	HVCC-1.0	HVCC-0.8	-	V	Io=-1mA, IN=HVCC-0.8V
Minimum Output Voltage	VoL	-	0.1	0.16	V	Io=1mA, IN=0V
【WHOLE】						
Reference Voltage	VREF	2.46	2.53	2.60	V	
Oscillation Frequency	FSW	550	650	750	kHz	
UVLO Voltage	UVLO	0.88	-	1.17	V	
Average Supply Current (VCC, PVCC2, 3)	ICC	-	5	11	mA	No Switching
Average Supply Current (HVCC)	HICC	-	1.0	4	mA	No Switching

○ This product is not designed for protection against radioactive rays.

● PHYSICAL DIMENSION - MARKING (VQFN048V7070)

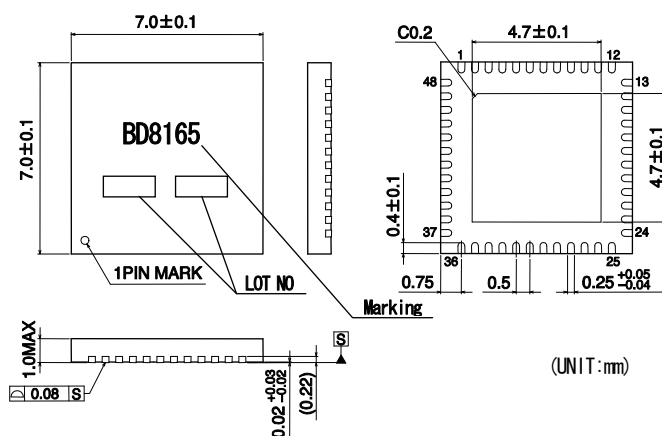

●BLOCK DIAGRAM

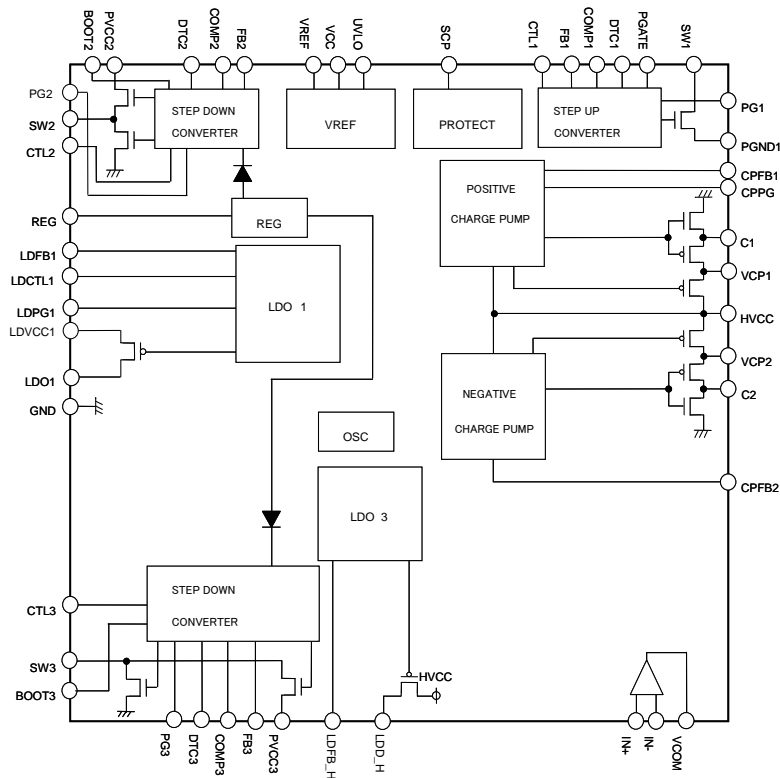

●PIN No. & FUNCTION TABLE

PIN NO.	PIN NAME	FUNCTION	PIN NO.	PIN NAME	FUNCTION
1	BOOT3	Boot strap Terminal 3	25	COMP1	Error Amp Output 1
2	PG3	Power Good Output 3	26	FB1	Feed Back Input 1
3	DTC3	DUTY Control Input 3	27	CTL1	Control Input 1
4	COMP3	Error Amp Output 3	28	SCP	Short Protection Current Output
5	FB3	Feed Back Input 3	29	VCC	Power Supply Input
6	PVCC3	Power Supply Input	30	UVLO	UVLO Input
7	LDFB_H	LDO Feed Back Input H	31	VREF	Reference Voltage Output
8	LDO_H	LDO Output H	32	FB2	Feed Back Input 2
9	IN+	COM Input +	33	COMP2	Error Amp Output 2
10	IN-	COM Input -	34	DTC2	DUTY Control Input 2
11	VCOM	COM Output	35	PVCC2	Power Supply Input
12	CPFB2	Charge Pump Feed Back Input 2	36	BOOT2	Boot strap Terminal 2
13	C2	Charge Pump Input2	37	PG2	Power Good Output 2
14	VCP2	Charge Pump LDO Output 2	38	SW2	Power Switch Output 2
15	HVCC	Power Supply Input	39	CTL2	Control Input 2
16	VCP1	Charge Pump LDO Output 1	40	REG	Boot strap Regulator Output
17	C1	Charge Pump Output 1	41	LDFB1	LDO Feed Back Input 1
18	CPPG	CP Power Good Output	42	LDCTL1	LD01 Control Input
19	CPFB1	Charge Pump Feed Back Input 1	43	LDPG1	LD01 Power Good Output
20	PGND1	Ground	44	LDO1	LDO Output 1
21	PG1	Power Good Output 1	45	LDVCC1	Power Supply Input
22	SW1	Power Switch Output 1	46	GND	Ground
23	PGATE	Pch Gate Drive Output	47	CTL3	Control Input 3
24	DTC1	DUTY Control Input 1	48	SW3	Power Switch Output 3

●Operation Notes

1. Absolute maximum range

This product are produced with strict quality control, but might be destroyed in using beyond absolute maximum ratings. Open IC destroyed a failure mode cannot be defined (like Short mode, or Open mode).

Therefore physical security countermeasure, like fuse, is to be given when a specified mode to be beyond absolute maximum ratings is considered.

2. Ground potential

GND terminal should be a lowest voltage potential every state.

Please make sure all pins which is over ground even if include transient feature.

3. Setting of heat

Use a setting of heat that allows for a sufficient margin in light of the power dissipation (Pd) in actual operating conditions..

4. Short Circuit between Terminal and Soldering

Don't short-circuit between Output pin and the power supply pin, Output pin and GND pin, or the power supply pin and GND pin. When soldering the IC on circuit board, please be unusually cautious about the orientation and the position of the IC. When the orientation is mistaken the IC may be destroyed.

5. Electromagnetic Field

Mal-function may happen when the device is used in the strong electromagnetic field.

6. Ground wiring patterns

When using both small signal and large current GND patterns, it is recommended to isolate the two ground patterns, placing a single ground point at the application's reference point so that the pattern wiring resistance and voltage variations caused by large currents do not cause variations in the small signal ground voltage. Be careful not to change the GND wiring patterns of any external components.

7. This IC is a monolithic IC which has P+ isolation in the P substrate and between the various pins.

A P-N junction is formed from this P layer and the N layer of each pin.

For example, when a resistor and a transistor is connected to a pin.

Parasitic diodes can occur inevitably in the structure of the IC. The operation of parasitic diodes can result in mutual interference among circuits as well as operation faults and physical damage. Accordingly, you must not use methods by which parasitic diodes operate, such as applying a voltage that is lower than the GND (P substrate) voltage to an input pin.

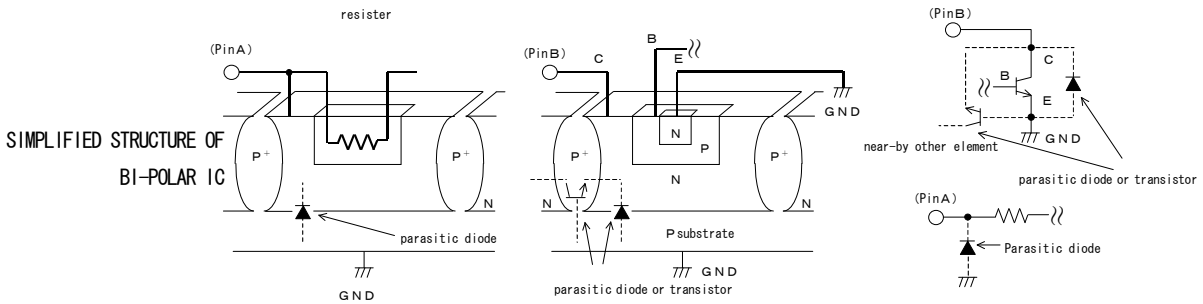

8. Over current protection circuit

The over-current protection circuits are built in at output, according to their respective current outputs and prevent the IC from being damaged when the load is short-circuited or over-current. But, these protection circuits are effective for preventing destruction by unexpected accident. When it's in continuous protection circuit moving period don't use please. And for ability, because this chip has minus characteristic, be careful for heat plan.

9. Built-in thermal circuit

A temperature control circuit is built in the IC to prevent the damage due to overheat.

Therefore, all the outputs are turned off when the thermal circuit works and are turned on when the temperature goes down to the specified level.

10. Testing on application boards

When testing the IC on an application board, connecting a capacitor to a pin with low impedance subjects the IC to stress. Always discharge capacitors after each process or step. Ground the IC during assembly steps as an antistatic measure, and use similar caution when transporting or storing the IC. Always turn the IC's power supply off before connecting it to or removing it from a jig or fixture during the inspection process.

11. Discontiguous mode

The DC/DC converters of this IC are designed for being used in contiguous current mode, normally. The special consideration on adjusting the inductance or the resistive output load to avoid the discontiguous current mode should be properly done.

Notes

No copying or reproduction of this document, in part or in whole, is permitted without the consent of ROHM Co.,Ltd.

The content specified herein is subject to change for improvement without notice.

The content specified herein is for the purpose of introducing ROHM's products (hereinafter "Products"). If you wish to use any such Product, please be sure to refer to the specifications, which can be obtained from ROHM upon request.

Examples of application circuits, circuit constants and any other information contained herein illustrate the standard usage and operations of the Products. The peripheral conditions must be taken into account when designing circuits for mass production.

Great care was taken in ensuring the accuracy of the information specified in this document. However, should you incur any damage arising from any inaccuracy or misprint of such information, ROHM shall bear no responsibility for such damage.

The technical information specified herein is intended only to show the typical functions of and examples of application circuits for the Products. ROHM does not grant you, explicitly or implicitly, any license to use or exercise intellectual property or other rights held by ROHM and other parties. ROHM shall bear no responsibility whatsoever for any dispute arising from the use of such technical information.

The Products specified in this document are intended to be used with general-use electronic equipment or devices (such as audio visual equipment, office-automation equipment, communication devices, electronic appliances and amusement devices).

The Products specified in this document are not designed to be radiation tolerant.

While ROHM always makes efforts to enhance the quality and reliability of its Products, a Product may fail or malfunction for a variety of reasons.

Please be sure to implement in your equipment using the Products safety measures to guard against the possibility of physical injury, fire or any other damage caused in the event of the failure of any Product, such as derating, redundancy, fire control and fail-safe designs. ROHM shall bear no responsibility whatsoever for your use of any Product outside of the prescribed scope or not in accordance with the instruction manual.

The Products are not designed or manufactured to be used with any equipment, device or system which requires an extremely high level of reliability the failure or malfunction of which may result in a direct threat to human life or create a risk of human injury (such as a medical instrument, transportation equipment, aerospace machinery, nuclear-reactor controller, fuel-controller or other safety device). ROHM shall bear no responsibility in any way for use of any of the Products for the above special purposes. If a Product is intended to be used for any such special purpose, please contact a ROHM sales representative before purchasing.

If you intend to export or ship overseas any Product or technology specified herein that may be controlled under the Foreign Exchange and the Foreign Trade Law, you will be required to obtain a license or permit under the Law.



Thank you for your accessing to ROHM product informations.
More detail product informations and catalogs are available, please contact us.

ROHM Customer Support System

<http://www.rohm.com/contact/>

Mouser Electronics

Authorized Distributor

Click to View Pricing, Inventory, Delivery & Lifecycle Information:

[ROHM Semiconductor:](#)

[BD8165MUV-E2](#)