

The 24bit Audio CODEC series

# Monaural Audio CODEC with Touch Panel Interface

## BU26154MUV

### General Description

BU26154 is a low-power compact audio CODEC. BU26154 also incorporates touch panel interface and Cap-Less headphones amplifier, speaker amplifier which is most suitable for digital still cameras, electronic dictionaries. BU26154 has built-in voltage regulator for the stability of CODEC characteristic that is sensitive to the outside noise. Speaker amplifier that can change AB / D Class. Therefore, when the interference including the FM radio influences it, BU26154 can prevent interference by operating AB grade. As digital code processing, it is equipped with the high-pass filter as the noise cut use of the specific frequency band, Notch filter and the Equalizer of 5 bands and P<sup>2</sup>Bass+, Noise gate, and flexible sound quality effect processing is possible.

### Features

- Various sound processing functions
  - ◇ P<sup>2</sup>Bass+
  - ◇ Noise gate
  - ◇ Fast release ALC
  - ◇ 5-band Equalizer/Notch Filter
- High PSRR is attained by built-in regulator
- Speaker amplifier can be switched to AB class and D class.
- Touch panel interface.

### Applications

- Electronic Dictionary
- Digital Still Camera
- Digital Single-lens Reflex Camera
- Digital Mirror-less Camera
- Digital Video Camera, others

### Typical Application Circuit(s)

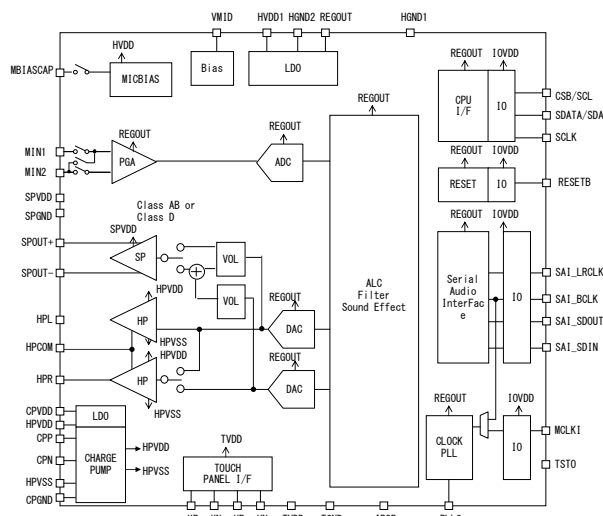

Figure 1. Block Diagram

### Key Specifications

■ HVDD Power Supply:	2.7V to 3.6V
■ SPVDD Power Supply:	2.7V to 5.5V
■ CPVDD Power Supply:	2.7V to 3.6V
■ TVDD Power Supply:	2.7V to 3.6V
■ MIC-ADC SNR:	92dB(Typ)
■ DAC-SP SNR:	95dB (Typ)
■ DAC-HP SNR:	93dB (Typ)

### Package(s)

VQFN040V6060

W (Typ) x D (Typ) x H (Max)  
6.00mm x 6.00mm x 1.00mm



VQFN040V6060

Pin Configuration(s)

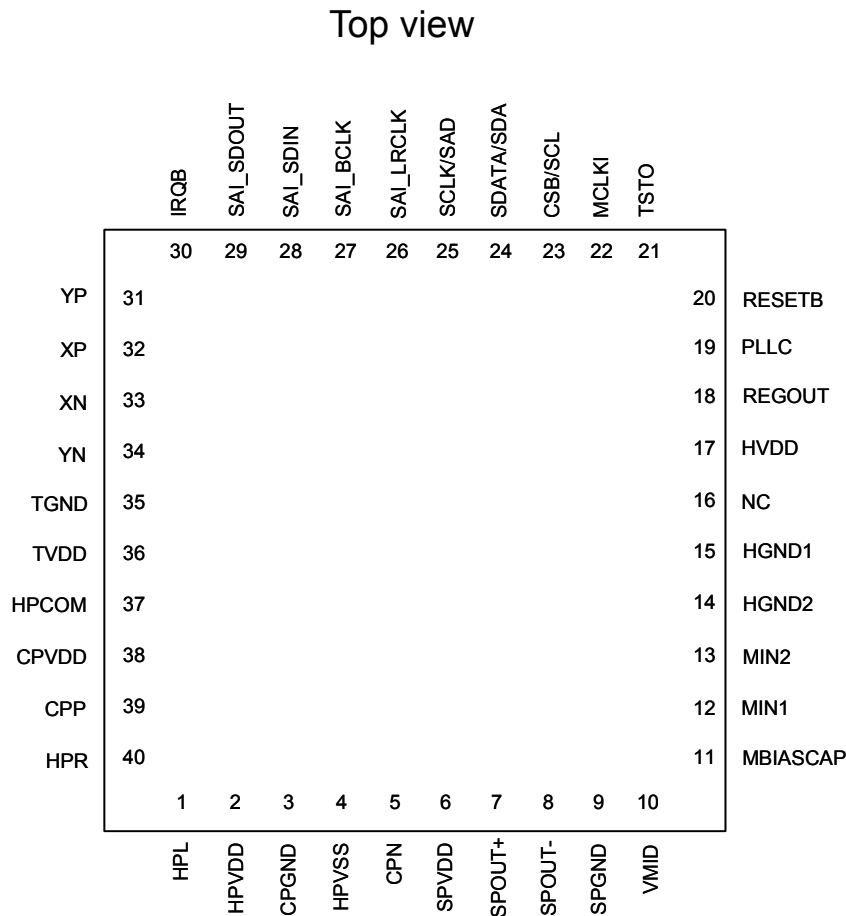

Figure 2. Pin Configuration(s)

Pin Description(s)

No	Name	I/O	Power	Function	Reset (Note1)	No use (Note3)
17	HVDD	P	-	High voltage power supply pin A capacitor is connected between HVDD and HGND1.	-	-
6	SPVDD	P	-	Speaker power supply pin A capacitor is connected between SPVDD and SPGND.	-	-
38	CPVDD	P	-	Voltage power supply pin for charge pump A capacitor is connected between CPVDD and CPGND.	-	-
16	N.C	-	-	A no connect pin.	-	-
36	TVDD	P	-	Voltage power supply for the touch panel Please connect a capacitor between TVDD and TGND.	-	-
15	HGND1	P	-	High voltage ground 1 It is used on the same voltage as HGND2, SPGND, CPGND, and TGND.	-	-
14	HGND2	P	-	High voltage ground 2 It is used on the same voltage as HGND1, SPGND, CPGND, and TGND.	-	-
9	SPGND	P	-	Ground pin for Speaker It is used on the same voltage as HGND1, HGND2, CPGND, and TGND.	-	-
3	CPGND	P	-	Ground pin for charge pump It is used on the same voltage as HGND1, HGND2, SPGND, and TGND.	-	-
35	TGND	P	-	Ground pin for touch panel interface It is used on the same voltage as HGND1, HGND2, CPGND, and SPGND.	-	-
18	REGOUT	O	HVDD	Regulator output A capacitor is connected between REGOUT and HGND1. Please connect as close as possible to the chip.	HGND2	-

2	HPVDD	O	CPVDD	A positive side voltage output pin for the headphones driver. A capacitor is connected between HPVDD and CPGND. Please connect as close as possible to the chip.	CPGND	(Note 2)
4	HPVSS	O	CPVDD	A negative side voltage output pin for the headphones driver. A capacitor is connected between HPVSS and CPGND. Please connect as close as possible to the chip.	CPGND	(Note 2)
22	MCLKI	I	HVDD	Master Clock pin	(input)	HGND1
21	TSTO	O	HVDD	Output pin for test-mode. Make it open.	HGND1	Open
20	RESETB	I	HVDD	Reset pin "L" level: Reset enables. "H" level: Reset disable.	(input)	-
24	SDATA /SDA	IO	HVDD	3 wire interface: data input output pin It is indicated as SDATA. 2 wire interface: data input output pin <sup>(Note 1)</sup> It is indicated as SDA.	(input)	-
25	SCLK /SAD	I	HVDD	3 wire interface: Serial clock input pin It is indicated as SCLK. 2 wire interface: Slave address select input pin. It is indicated as SAD. SAD pin = "L" level slave address is "0011010" SAD pin = "H" level slave address is "0011011"	(input)	HGND1
23	CSB /SCL	I	HVDD	3 wire interface: chip select input pin It is indicated as CSB. 2 wire interface: Serial clock input pin *1 It is indicated as SCL.	(input)	-
26	SAI_LRCLK	IO	HVDD	SAI LR clock input/output pin	(input)	HGND1
27	SAI_BCLK	IO	HVDD	SAI bit clock input/output pin	(input)	HGND1
28	SAI_SDIN	I	HVDD	SAI serial data input pin	(input)	HGND1
29	SAI_SDO	O	HVDD	SAI serial data output pin	HGND1	Open
30	IRQB	O	HVDD	An interrupt output terminal. When an interrupt occurs, chip outputs "L".	HGND1	Open
10	VMID	O	REGOUT	Analog reference voltage pin A capacitor is connected between VMID and HGND2.	HGND2	-
11	MBIASCAP	O	HVDD	Microphone bias voltage output pin A capacitor is connected between HGND2. Please connect as close as possible to the chip.	HGND2	Open
12	MIN1	I	REGOUT	Analog microphone input 1 Single-end and differential can be chosen. When differential is chosen, it connects with microphone + pin.	Hi-Z	Open
13	MIN2	I	REGOUT	Analog microphone input 2 Single-end and differential can be chosen. When differential is chosen, it connects with microphone - pin.	Hi-Z	Open
8	SPOUT-	O	SPVDD	speaker output - pin	SPGND	Open
7	SPOUT+	O	SPVDD	speaker output + pin	SPGND	Open
1	HPL	O	SPVDD	Headphones output Lch terminal	CPGND	Open
40	HPR	O	SPVDD	Headphones output Rch terminal	CPGND	Open
39	CPP	O	CPVDD	Charge pump flying capacitor, positive side output pin	Hi-Z	Open
5	CPN	O	CPVDD	Charge pump flying capacitor, negative side output pin	Hi-Z	Open
19	PLLC	O	HVDD	PLL filter pin When clock of the MCLKI pin input is used, make it open. When clock of the SAI_BCLK pin input is used, it is necessary to connect resistors and a capacitor.	HGND2	Open
31	YP	O	TVDD	YP pin for the touch panel interface	Hi-Z	Open
32	XP	O	TVDD	XP pin for the touch panel interface	Hi-Z	Open
33	XN	O	TVDD	XN pin for the touch panel interface	Hi-Z	Open
34	YN	O	TVDD	YN pin for the touch panel interface	Hi-Z	Open
37	HPCOM	I	-	Headphones amplifier common pin	(input)	-

(Note 1) In case of 2 wire serial, if this pin is used with external pull-up resistor, it possibly gets noise from power. Therefore, tamper noise design is required in the noisy environment.

(Note 2) At the time of power down, in HPVDD and HPVSS, is short-circuited.

Description of Block(s)

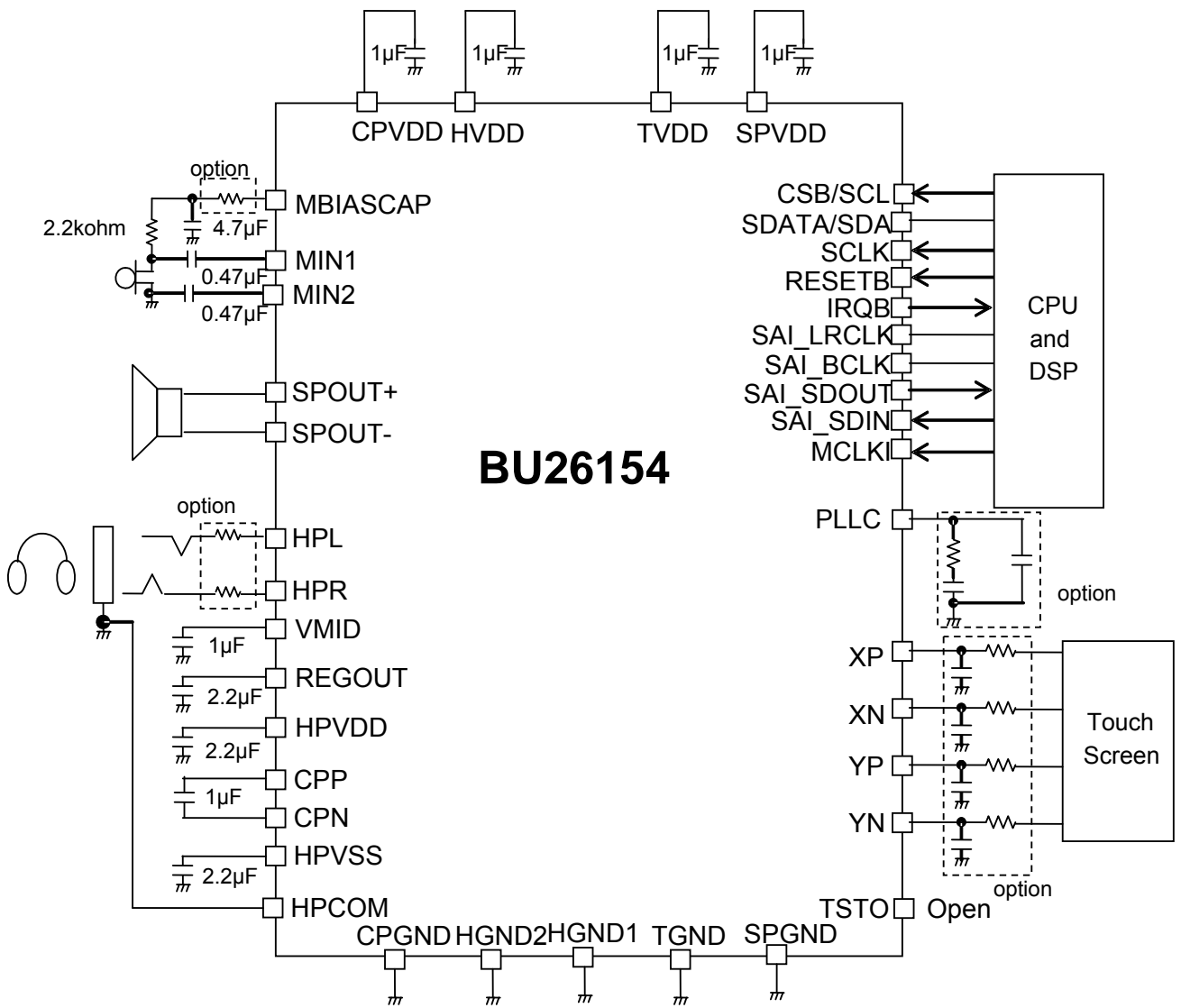

Figure 3. BU26154 Application circuit

**Absolute Maximum Ratings (Ta = 25°C)**

(HGND1=HGND2=SPGND=CPGND=TGND=0V)

Parameter	Symbol	Condition	Rating	Unit
HVDD Supply Voltage	HVDD	-	-0.3 to 4.5	V
SPVDD Supply Voltage	SPVDD	-	-0.3 to 7.0	V
CPVDD Supply Voltage	CPVDD	-	-0.3 to 4.5	V
Input Voltage	VIN	MCLKI, SAI_LRCLK, SAI_BCLK, SAI_SDIN, SDATA/SDA, SCLK, CSB/SCL pins	-0.3 to HVDD+0.3	V
		MIN1, MIN2 pins	-0.3 to REGOUT+0.3	V
Storage Temperature	T <sub>stg</sub>	-	-55 to +150	°C
Power Dissipation <sup>(Note 1)</sup>	Pd	Ta=25°C <sup>(Note 1)</sup>	0.80	W
		Ta=25°C <sup>(Note 2)</sup>	3.01	W
Output Current 1	IOSP	SPOUT+, SPOUT- pins	-560 to +560	mA
Output Current 2	IOHP	HPL, HPR pins	-100 to +100	mA
Output Current 3	IOCP	HPVSS,HPVDD,CP,CN pin	-500 to +500	mA
Output Current 4	IOREGO	REGOUT pin	-30 to 0	mA
Output Current 5	IOO	Except SPOUT+,SPOUT-, HPL,HPR, REGOUT,HPVDD,HPVSS pins	-8 to +8	mA

Do not short the output pin to another output pin, power supply pin or GND pin.(Output pin includes an IO pin which is in output mode)

(Note 1) 74.2mm×74.2mm×1.6mm FR4 1Layer Glass epoxy base Surface Copper foil 0% Mounting

Above Ta=25°C, reduced by 8.0mW/°C. Thermal beer is on a base.

(Note 2) 74.2mm×74.2mm×1.6mm FR4. 4 Layer Glass epoxy base(2,3layer Copper foil 100%) Mounting

Above Ta=25°C, reduced by 30.12mW/°C. Thermal beer is on a base.

**Caution:** Operating the IC over the absolute maximum ratings may damage the IC. The damage can either be a short circuit between pins or an open circuit between pins and the internal circuitry. Therefore, it is important to consider circuit protection measures, such as adding a fuse, in case the IC is operated over the absolute maximum ratings.**Recommended Operating Conditions**

(HGND1=HGND2=SPGND=CPGND=TGND=0V)

Parameter	Symbol	Condition	Rating	Unit
HVDD Supply Voltage	HVDD	HVDD=CPVDD=TVDD	2.7 to 3.6	V
SPVDD Supply Voltage	SPVDD	-	2.7 to 5.5	V
CPVDD Supply Voltage	CPVDD	HVDD=CPVDD=TVDD	2.7 to 3.6	V
TVDD Supply Voltage	TVDD	HVDD=CPVDD=TVDD	2.7 to 3.6	V
Operating Temperature	T <sub>op</sub>	-	-20 to +85	°C

(Note 1) The radiation-proof design is not carried out.

## Electrical Characteristics

## DC Characteristics

(HGND1= HGND2=SPGND=CPGND=TGND=0V, HVDD=3.3V, SPVDD=3.3V, CPVDD=3.3V, TVDD=3.3V, Ta=25°C)

Parameter	Symbol	Conditions	Min	Typ	Max	Unit	Related Pin
"H" Input Voltage1	VIH1	HGND1=0V	HVDD *0.8	-	HVDD+0.3	V	All Digital Input
"L" Input Voltage 1	VIL1	HGND1=0V	-0.3	-	HVDD *0.2	V	All Digital Input
"H" Input Voltage 2	VIH2	HGND1=0V	HVDD-0.4	-	HVDD+0.3	V	All Digital Input
"L" Input Voltage 2	VIL2	HGND1=0V	-0.3	-	0.4	V	All Digital Input
"H" output Voltage	VOH	IOH=-1mA	HVDD *0.85	-	-	V	Except SDA
"L" output Voltage 1	VOL1	IOL=1mA	-	-	HVDD *0.15	V	Except SDA
"L" output Voltage 2	VOL2	IOL=3mA	-	-	0.4	V	SDA
"H" Input Leakage Current	IiH	VIH= HVDD	-	-	10	μA	All Digital Input
"L" Input Leakage Current	IiL	VIL=HGND1	-10	-	-	μA	All Digital Input
"Z" output Leakage Current	IOZH	VOH=HVDD	-	-	10	μA	SDA
"Z" output Leakage Current	IOZL	VOL=HGND1	-10	-	-	μA	SDA
Operating Current1	IDDO1	Playback(fs48kHz) no Load, Hp-amp use Sin1kHz-Full Scale output	-	10	13	mA	-
Operating Current2	IDDO2	Playback(fs48kHz) no Load, D-class, Sp-amp use Sin1kHz-Full Scale output	-	10.5	13.7	mA	-
Operating Current3	IDDO3	Playback(fs48kHz) no Load, AB-class, Sp-amp use Sin1kHz-Full Scale output	-	12	15.6	mA	-
Operating Current4	IDDO4	Record(fs48kHz) Sin1kHz-Full Scale input	-	9.5	12.4	mA	-
Operating Current5	IDDO5	Touch Panel Interface Operate	-	0.6	1	mA	-
Operating Current6 (Note 3)	IDDO6	Touch Panel Interface Interrupt Wait Ta = -40 to 55 °C	-	220	320	uA	-
Standby Current	IDDS	25 °C	-	0.5	5	μA	-

(Note 1) Touch Panel Interface Interrupt electric current at the time of the wait. Please refer to a touch panel interface clause for the movement setting condition.

(Note 2) Standby current is total value for all power supply currents.

(Note 3) Standby current's condition is power off state by RESETB=L

AC Characteristics

Clock

PLL not used

(HGND1= HGND2=SPGND=CPGND=TGND=0V, HVDD=3.3V, SPVDD=3.3V, CPVDD=3.3V, TVDD=3.3V, Ta=25°C)

Parameter	Symbol	Min	Max	Unit
MCLKI Frequency	fC	4.096	49.152	MHz
MCLKI Period	tC	1/fC	1/fC	ns
MCLKI "H" Length	tCH	tC*0.4	-	ns
MCLKI "L" Length	tCL	tC*0.4	-	ns

PLL used

(HGND1= HGND2=SPGND=CPGND=TGND=0V, HVDD=3.3V, SPVDD=3.3V, CPVDD=3.3V, TVDD=3.3V, Ta=25°C)

Parameter	Symbol	Min	Max	Unit
MCLKI Frequency	fC	6.75	54	MHz
MCLKI Period	tC	1/fC	1/fC	ns
MCLKI "H" Length	tCH	tC*0.4	-	ns
MCLKI "L" Length	tCL	tC*0.4	-	ns

When PLL is use, clock from SAI\_BCLK pin other than MCLKI pin could be inputted. Please refer to SAI slave clause about the BCLK pin input frequency.

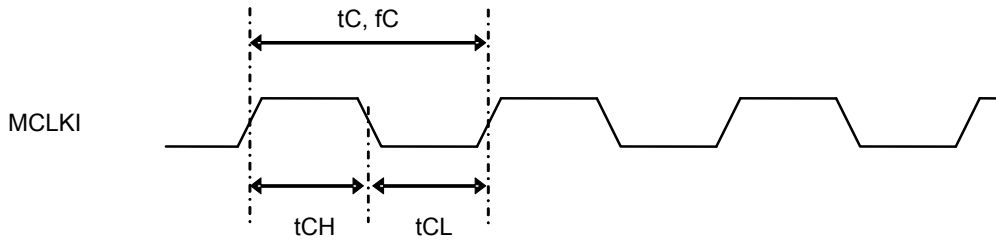

Figure 4

Reset

(HGND1= HGND2=SPGND=CPGND=TGND=0V, HVDD=3.3V, SPVDD=3.3V, CPVDD=3.3V, TVDD=3.3V, Ta=25°C)

Parameter	Symbol	Min	Max.	Unit
RESETB pulse width	tW_RST	5	-	μ s

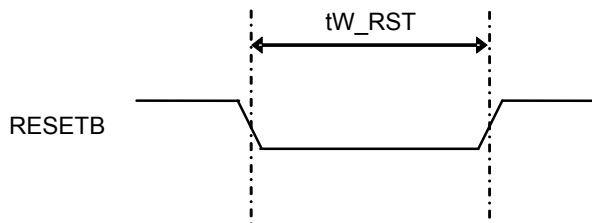

Figure 5

When Reset pin is made low-level, internal LDO goes to power mode. 1ms is necessary until REGOUT pin becomes low-level. The recommended tW\_RST is over 1ms.

**2-Wire Serial Interface**

(HGND1= HGND2=SPGND=CPGND=TGND=0V, HVDD=3.3V, SPVDD=3.3V, CPVDD=3.3V, TVDD=3.3V, Ta=25°C, CL=30pF)

Parameter	Symbol	Standard Mode		Fast Mode		Unit
		Min	Max	Min	Max	
SCL Frequency	$f_{SCL}$	-	100	-	400	kHz
SCL "L" Length	$t_{LOW}$	4.7	-	1.3	-	$\mu s$
SCL "H" Length	$t_{HIGH}$	4.0	-	0.6	-	$\mu s$
Hold Time under Repeat [Start] Condition	$t_{HD:STA}$	4.0	-	0.6	-	$\mu s$
Setup Time under Repeat [Start] Condition	$t_{SU:STA}$	4.0	-	0.6	-	$\mu s$
Data Hold Time	$t_{HD:DAT}$	0	3.45	0	0.9	$\mu s$
Data Setup Time	$t_{SU:DAT}$	250	-	100	-	ns
Setup Time under [Stop] Condition	$t_{SU:STO}$	4.0	-	0.6	-	$\mu s$

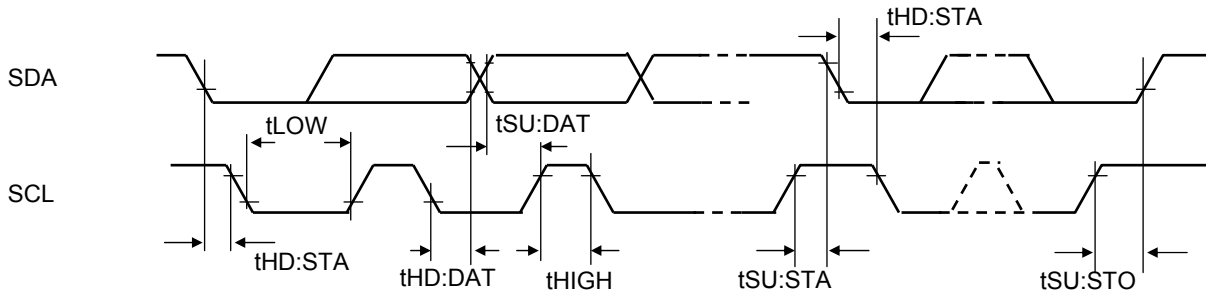

Figure 6

**3-Wire Serial Interface**

(HGND1= HGND2=SPGND=CPGND=TGND=0V, HVDD=3.3V, SPVDD=3.3V, CPVDD=3.3V, TVDD=3.3V, Ta=25°C, CL=30pF)

Parameter	Symbol	Min	Max	Unit
SCLK Low to Chip Select enable	tSLCL	100	-	ns
Chip Select Enable to SCLK Low	tCLSL	100	-	ns
Chip Select Enable to SCLK High	tCLSH	100	-	ns
CLK High to Chip Select enable	tSHCL	100	-	ns
SCLK High Pulse Width	tSH	50	-	ns
SCLK Low Pulse Width	tSL	50	-	ns
Input Data Setup time	tIDS	30	-	ns
Input Data Hold time	tIDH	30	-	ns
SCLK last edge to Chip Select disable	tCHS2	100	-	ns
Chip Select High Pulse Width	tCH	100	-	ns
Output Data Valid	tODV	-	40	ns
Chip Select High to Data Transition	tCHDTS	-	40	ns

Two kinds of timing are supported depending on the SCLK pin level at data transfer start. Read or Write is selected by LSB logic INDEX.

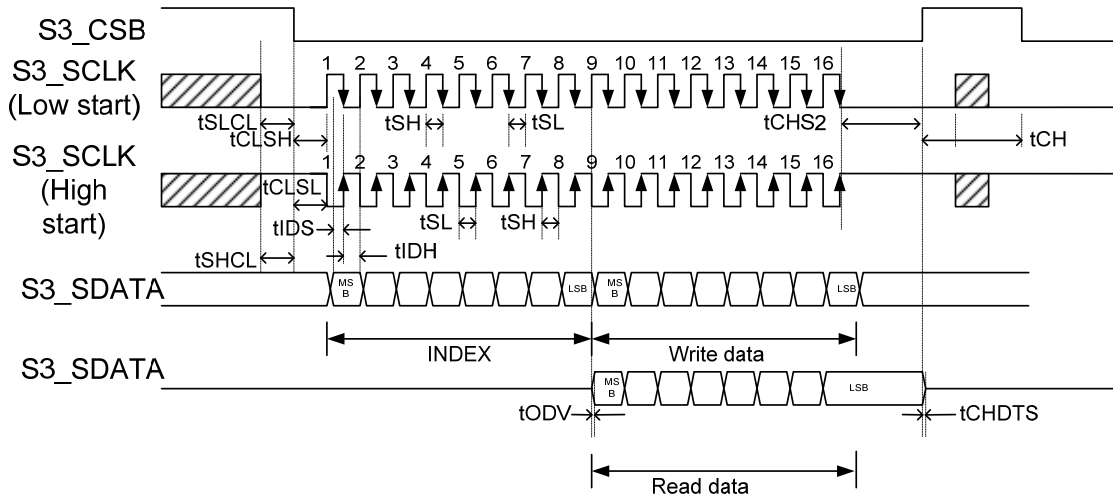

Figure 7

**Serial Audio Interface (Slave)**

(HGND1= HGND2=SPGND=CPGND=TGND=0V, HVDD=3.3V, SPVDD=3.3V, CPVDD=3.3V, VDD=3.3V, Ta=25°C, CL=30pF)

Parameter	Symbol	Min	Max	Unit
SAI_BCLK Period	tC_BCLK	32fs	128fs	Hz
SAI_BCLK "H" Length	tHW_BCLK	73	-	ns
SAI_BCLK "L" Length	tLW_BCLK	73	-	ns
SAI_LRCLK Hold Time	tH_LRCLK	20	-	ns
SAI_LRCLK Setup Time	tSU_LRCLK	20	-	ns
SAI_SDOUT Delay Time	tD_SDO (Note 1)	-	80	ns
SAI_SDIN Setup Time	tSU_SDI	20	-	ns
SAI_SDIN Hold Time	tH_SDI	20	-	ns

(Note 1) tD\_SDO is the delay time from previous SAI\_BCLK transition and SAI\_LRCLK transition.

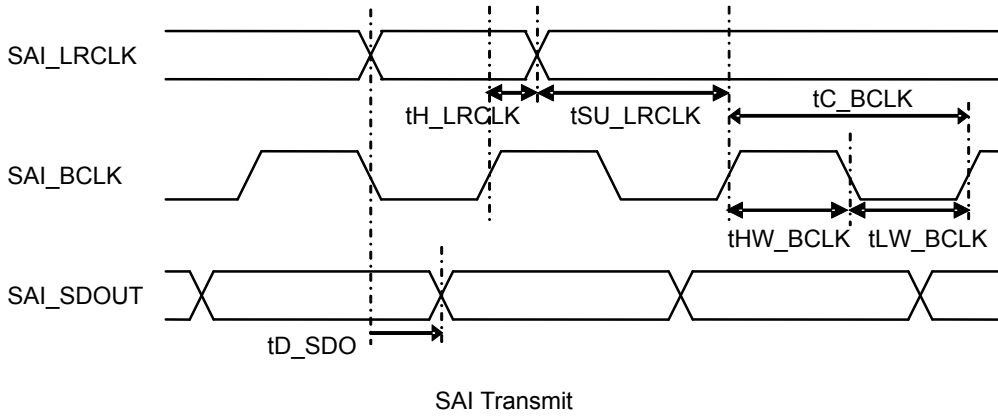

Figure 8

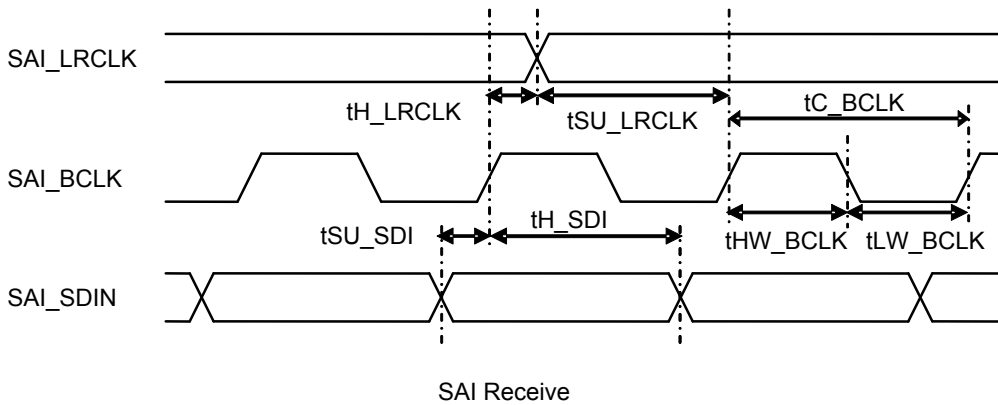
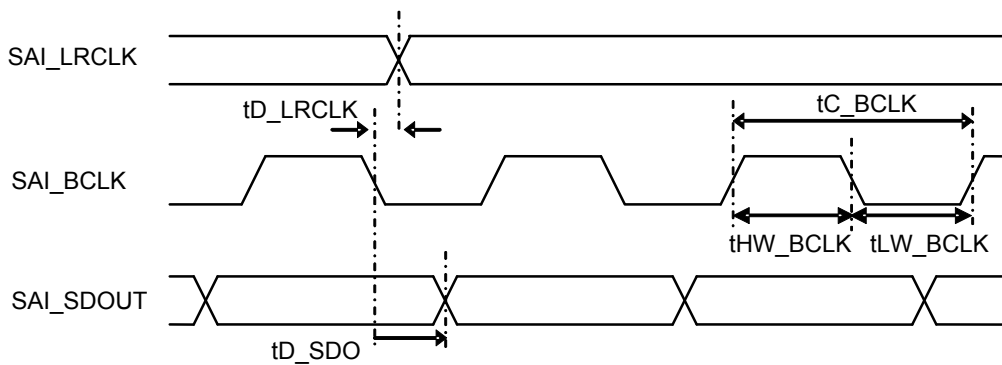

Figure 9

**SAI (Master) - Serial Audio Interface (Master)**

(HGND1= HGND2=SPGND=CPGND=TGND=0V, HVDD=3.3V, SPVDD=3.3V, CPVDD=3.3V, TVDD=3.3V, Ta=25°C, CL=30pF)

Parameter	Symbol	Min	Max	Unit
SAI_BCLK Period	tC_BCLK	32fs	64fs	Hz
SAI_BCLK "H" Length	tHW_BCLK	146	-	ns
SAI_BCLK "L" Length	tLW_BCLK	146	-	ns
SAI_LRCLK Delay time	tD_LRCLK	-	20	ns
SAI_SDOOUT Delay Time	tD_SDO	-	20	ns
SAI_SDIN Setup Time	tSU_SDI	50	-	ns
SAI_SDIN Hold Time	tH_SDI	0	-	ns



SAI Transmit  
Figure 10

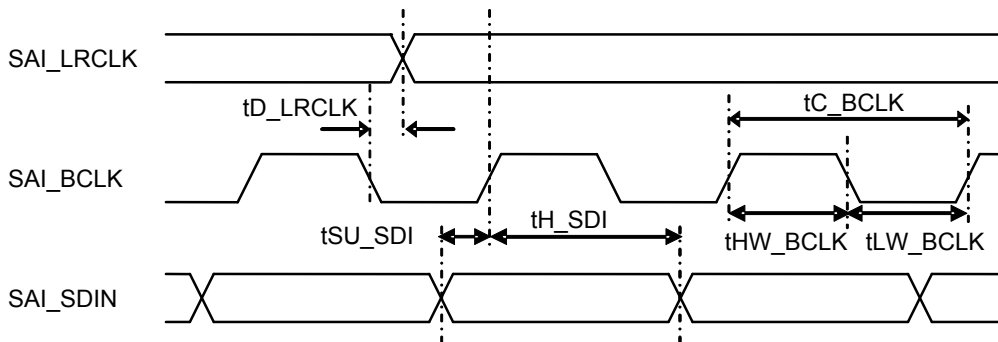

SAI Receive  
Figure 11

**Power Supply Sequence**

Please power on/off the LSI with all kind of power at the same time.  
 Each power supply should power up/down in 50ms. Also, keep all power supply in the ON state or the OFF state.  
 Please avoid partial ON or partial OFF states.

Please keep RESETB pin “L” level until all power supply become ON state. The CPU I/F become available when all power supply is powered on after  $t_{w\_PURST}$  and  $t_{w\_REGU}$  time exceeds.  
 HVDD must be powered on first, but HVDD must be powered off last. About SPVDD, there is no limitation above.

Parameter	Symbol	Min	Typ	Max	Unit
Power On Delay Time	$t_{VDD\_ON}$	0	-	50	ms
Power Off Delay Time	$t_{VDD\_OFF}$	0	-	50	ms
Reset Time after Power ON	$t_{w\_PURST}$	1	-	-	$\mu$ s
Wait Time for Regulator Starting after Reset Release	$t_{w\_REGU}$	1	-	-	ms

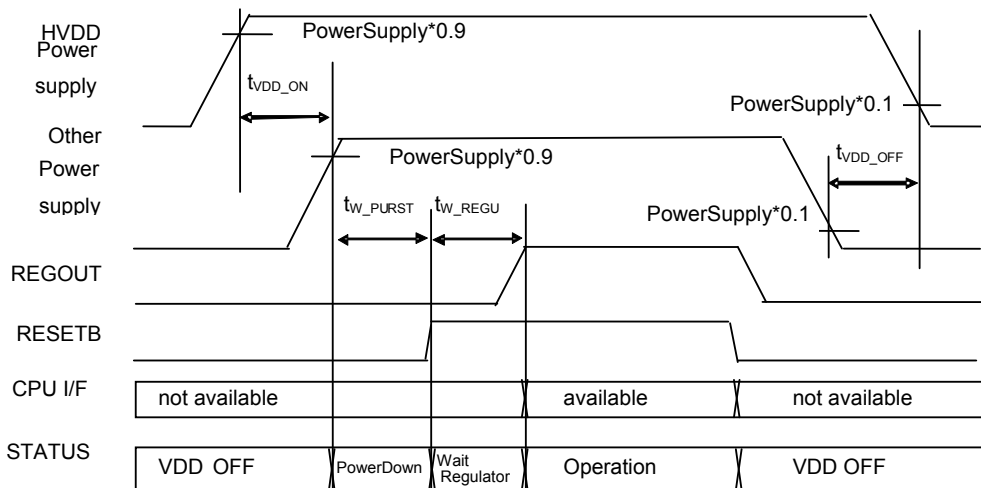

Figure 12

## Analog Characteristics

(HGND1= HGND2=SPGND=CPGND=TGND=0V, HVDD=3.3V, SPVDD=3.3V, CPVDD=3.3V, TVDD=3.3V, Ta=25°C)

Parameter	Symbol	Condition	Min	Typ	Max	Unit
Regulator Output						
REGOUT Output Level	VREGOUT	-	1.7	1.8	1.9	V
Mic Input (MIC Gain=18dB / Digital Volume=0.0dB / ALC=OFF)						
Full Scale Input Signal Level	VMINFS1	MIN1,MIN2	-	-	0.124	Vp-p
Input Resistance	RMIN1	MIN1,MIN2	20	30	40	kΩ
Mic Input (MIC Gain=9.0dB / Digital Volume=0.0dB / ALC=OFF)						
Full Scale Input Signal Level	VMINFS2	MIN1,MIN2	-	-	0.454	Vp-p
Input Resistance	RMIN2	MIN1,MIN2	20	30	40	kΩ
Analog Reference Level(VMID-pin)						
Analog Reference Voltage	VREF	-	0.9x REGOUT/2	1.0x REGOUT/2	1.1x REGOUT/2	V
Microphone Bias(MBIASCAP -pin)						
Output Voltage where, VMIC<HVDD*0.85	VMIC	IMIC = -1mA, MICBCON=0	1.50x REGOUT/2	1.67x REGOUT/2	1.84x REGOUT/2	V
		IMIC = -1mA, MICBCON=1	2.00x REGOUT/2	2.22x REGOUT/2	2.45x REGOUT/2	V
		IMIC = -1mA, MICBCON=2	2.50x REGOUT/2	2.78x REGOUT/2	3.06x REGOUT/2	V
		IMIC = -1mA, MICBCON=3	3.00x REGOUT/2	3.33x REGOUT/2	3.67x REGOUT/2	V
Output Current	IMIC	-	-	-	2	mA

(HGND1=HGND2=SPGND=CPGND=TGND=0V, HVDD=3.3V, SPVDD=3.3V, CPVDD=3.3V, TVDD=3.3V, Ta=25°C)

Parameter	Symbol	Conditions	Min	Typ	Max	Unit
Analog Inputs to ADC out (MIC Gain=18dB / Digital Volume=0.0dB / ALC=OFF)						
S/(N+D)	SND1	-1dBFS/ A-weighted	-	78	-	dB
S/N	SNR1	A-weighted	-	89	-	dB
Power Supply Rejection Ratio	PSRR1	HVDD on 100mVp-p, 1kHz noise, no signal input	-	90	-	dB
Analog Inputs to ADC out (MIC Gain=9.0dB / Digital Volume=0.0dB / ALC=OFF)						
S/(N+D)	SND2	-1dBFS/ A-weighted	-	80	-	dB
S/N	SNR2	A-weighted	-	92	-	dB
Power Supply Rejection Ratio	PSRR2	HVDD on 100mVp-p, 1kHz noise, no signal input	-	90	-	dB
DAC to Headphone OUT(HPR/HPL, with 16Ω/50pF load)						
Total Harmonic Distortion	THD+N3	1kHz,input -12dBFS	-	75	-	dB
Signal to Noise Ratio	SNR3	A-weighted	-	93	-	dB
Power Supply Rejection Ratio	PSRR3	HVDD on 100mVp-p,1kHz noise, no signal input	-	90	-	dB
		CPVDD on 100mVp-p,1kHz noise, no signal input	-	90	-	dB
Output Offset Voltage	VOF	No signal input	-	±1	-	mV
Charge Pump Oscillator Frequency	CPOSC	-	-	500	-	kHz
HPVDD Port Output Voltage	HPVDO	-	-	1.8	-	V
HPVSS Port Output Voltage	HPVSO	-	-	-1.8	-	V
DAC to Speaker OUT D-class Mode (SPOUT+/-, with 8Ω/50pF load)						
Output Power	Po4	THD=10%, SPVOL=6dB	-	700	-	mW
Total Harmonic Distortion	THD+N4	Po=310mW	-	66	-	dB
Signal to Noise Ratio	SNR4	A-weighted, THD+N=1%	-	95	-	dB
Power Supply Rejection Ratio	PSRR4	HVDD on 100mVp-p,1kHz noise	-	90	-	dB
		SPVDD on 100mVp-p,1kHz noise	-	60	-	dB
PWM frequency	PWMF	-	-	370	-	kHz
Efficiency	EFF	-	-	90	-	%
DAC to Speaker OUT AB-class Mode (SPOUT+/-, with 8Ω/50pF load)						
Output Power	Po5	THD=10%, SPVOL=6dB	-	700	-	mW
Total Harmonic Distortion	THD+N5	Po=310mW	-	62	-	dB
Signal to Noise Ratio	SNR5	A-weighted, THD+N=1%	-	95	-	dB
Power Supply Rejection Ratio	PSRR5	HVDD on 100mVp-p,1kHz noise	-	90	-	dB
		SPVDD on 100mVp-p,1kHz noise	-	60	-	dB
Microphone Bias(MBIASCAP-pin) *1						
Output Noise Voltage	VMICN6	22Hz to 22kHz, MICBCON=1	-	5	-	μV
Power Supply Rejection Ratio	PSRR6	HVDD on 100mVp-p,1kHz noise Load=1mA MICBCON=1	-	70	-	dB

(HGND1=HGND2=SPGND=CPGND=TGND=0V, HVDD=3.3V, SPVDD=3.3V, CPVDD=3.3V, TVDD=3.3V, Ta=25°C)

Parameter	Symbol	Conditions	Min	Typ	Max	Unit
Touch Panel Interface						
ADC Resolution	N	-	-	-	12	Bit
Differential Non-Linearity Error	DNL	-	-3	-	3	LSB
Integral Non-Linearity Error	INL	-	-4	-	4	LSB
Offset Error	OFTERR	-	-	1	-	LSB
Gain Error	GAERR	-	-	0.5	-	LSB
Touch Panel Driver Switch	SWONR	-	-	5	-	Ω
Interrupt Pull-up Resistance	IRQR1	RSEL=0	40	50	70	kΩ
	IRQR2	RSEL=1	70	90	120	kΩ
ADC Conversion Timing	Tw_ADC1		-	-	35	μs
	Tw_ADC2		-	-	43	μs

## Function Description

### Clock Control

Main modules that make sound path of the LSI inside operate with 1024fs Audio Clock.

Audio Clock can be selected whether divided clock of 256fs/512fs/1024fs from MCLKI or generated clock from Audio PLL.

When PLL is used, PLL generates internal clock. The input clock into PLL can be selected from either MCLKI port or SAI\_BCLK port by setting Clock Input / Output Control register. PLL generates 256fs clock of sampling frequency.

The registers about Audio Clock setting: Sampling Rate Setting Register, FPLLM, FPLLNL, FPLLNH, FPLLD, FPLLFL, FPLLFH, FPLLFDL, FPLLFDH, Clock Input / Output Control register, Clock Input Select Register

#### • The sequence of PLL setting

1. Stop PLL output by setting PLLOE bit to "0".
2. Disable PLL by setting PLEN bit to "0".
3. Set FPLLM, FPPNL, FPLLNH, FPLLD, FPLLFL, FPLLFH, FPLLFDL, FPLLFDH.
4. Set input port by PLLISEL bit.
5. Set PLEN bit to "1".
6. Wait for the PLL stabilizing time as the table "PLL Stabilizing Time".
7. Set PLLOE bit to "1".
8. Start recording or playback.

#### PLL Stabilizing Time

PLL stability time
10msec

#### - Related Register

Sampling Rate Setting Register

PLLNL, PLLNH Register

PLLML, PLLMH Register

PLLDIV Register

Clock Enable Register

Clock Input / Output Control Register

When PLL is Used.

The LSI support audio PLL function that can generate precise audio clock from wide range of clock frequency. Then, it can be realize audio function without external clock generator for audio. The LSI supports following cases.

The LSI generates audio clock with input clock provided from MCLKI port or BCLKI port.

■case1: PLLISEL (0x0e/0x0f)=0x1, MST(0x64/0x65)="0"

Audio clock is generated by the PLL BU26154 with MCLKI clock. SAI\_LRCLK and SAI\_BCLK are provided by the CPU.

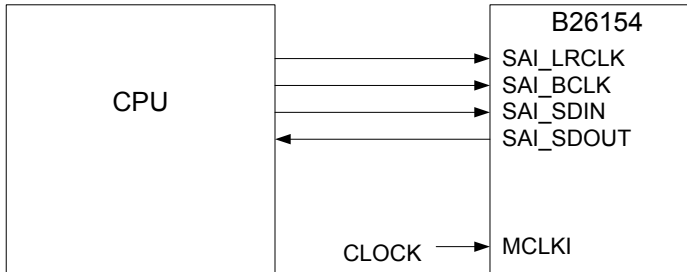

Figure 13

■case2: PLLISEL (0x0e/0x0f)=0x1, MST(0x64/0x65)="1"

Audio clock is generated by the PLL in BU26154 from MCLKI clock. SAI\_LRCLK and SAI\_BCLK are provided from the LSI.

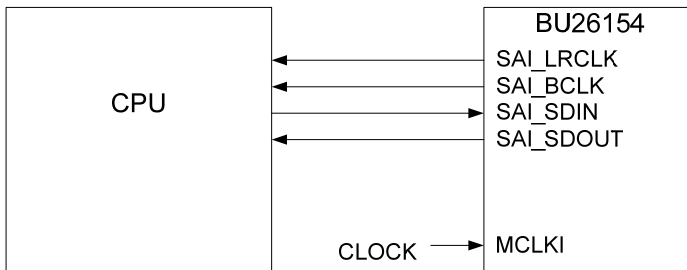

Figure 14

■case3: PLLISEL (0x0e/0x0f)=0x2, MST(0x64/0x65)="1"

Audio clock is generated by PLL in BU26154 form SAI clock.

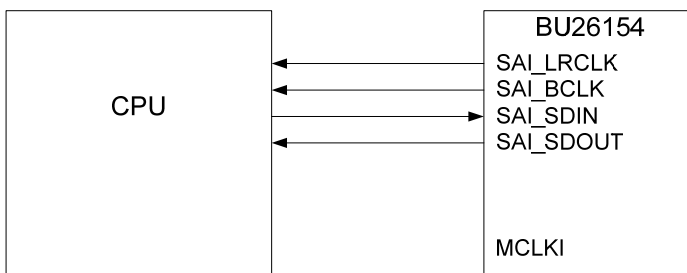

Figure 15

When PLL is not Used.

Audio clock is generated by the CPU and supplied to the LSI when PLL is not used. Then CPU and the LSI are synchronized.

■case 5: MST (0x64/0x65) = "0"

Audio clock (256fs, 512fs, 1024fs) is generated by the CPU and supplied to MCLKI port of the LSI. LRCLK and BCLK are also provided from the CPU.

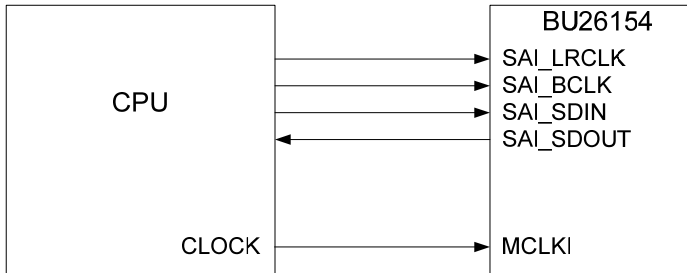

Figure 16

■case6: MST (0x64/0x65) = "1"

Audio clock (256fs, 512fs, 1024fs) is generated by the CPU and supplied to MCLKI port of the LSI. SAI\_LRCLK and SAI\_BCLK are provided from the LSI.

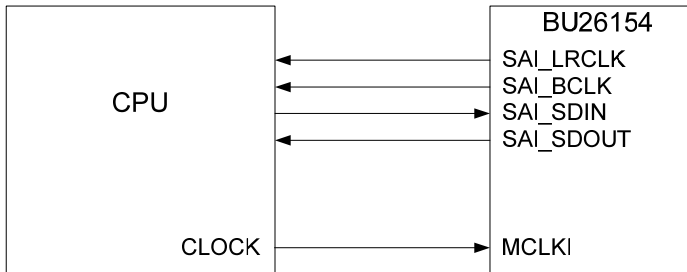

Figure 17

Even when using the same sampling frequency, the setting condition is different depending on clock frequency. When changing MCLKI input frequency, PLLOE should be set to "0", then PLLOE should be set to "1" back.

SAI (Serial Audio System Interface)

The LSI supports SAI formats.

WSLI="0", DLYI="0", FMTI="0"

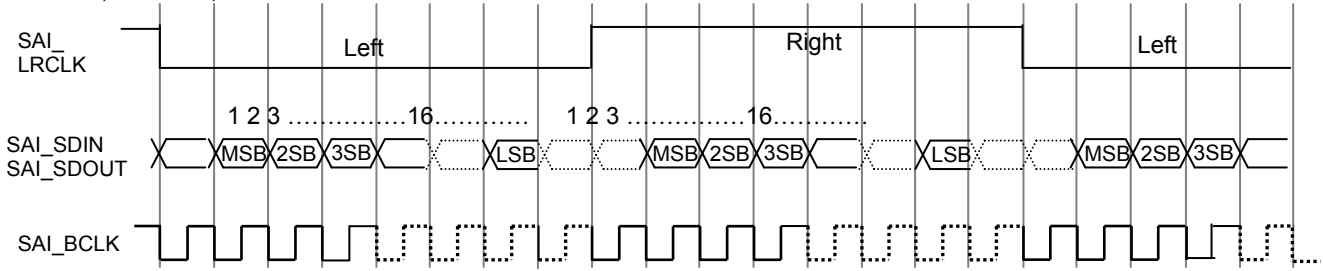

Figure 18

WSLI="1", DLYI="0", FMTI="0"

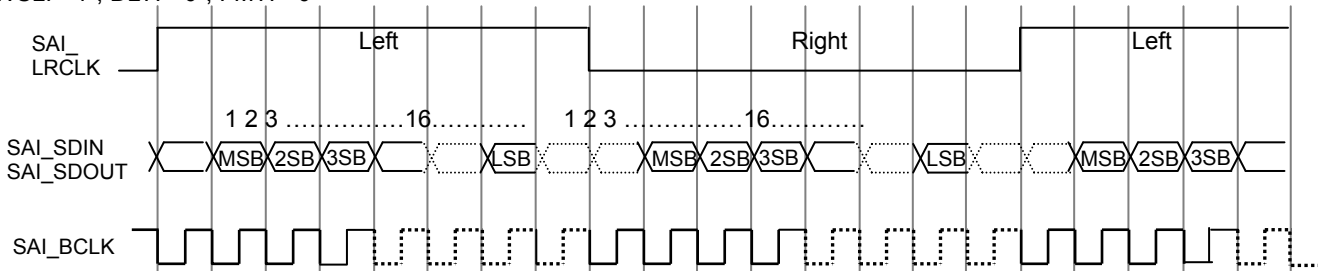

Figure 19

WSLI="0", DLYI="1", FMTI="0"

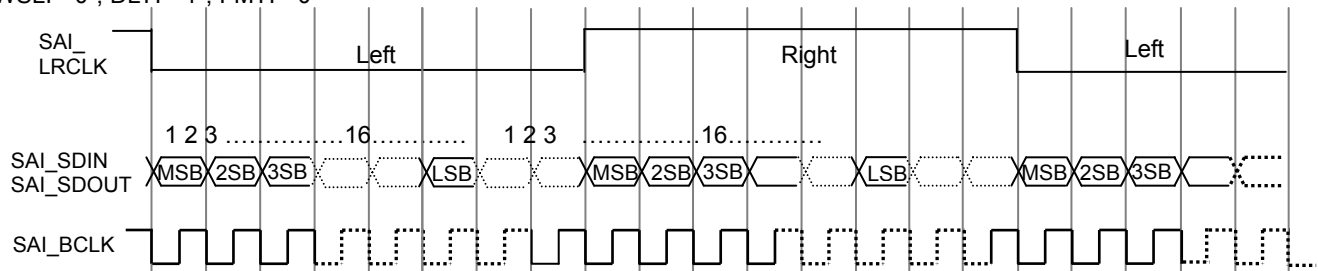

Figure 20

WSLI="1", DLYI="1", FMTI="0"

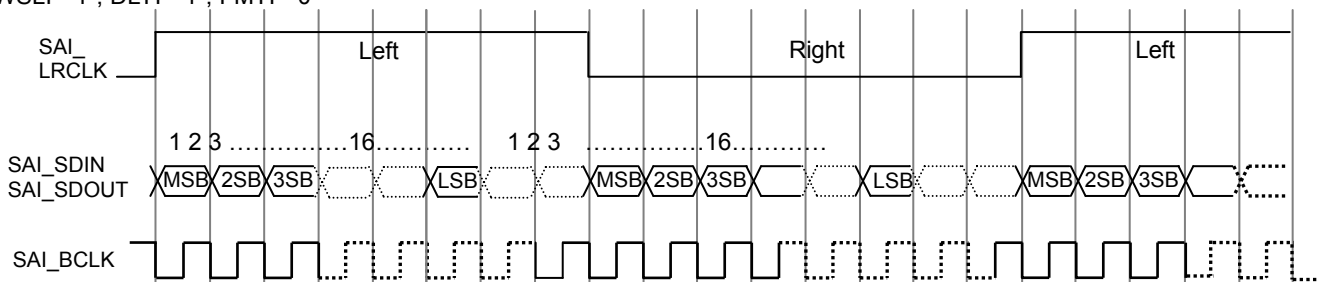

Figure 21

DLYI="0", FMTI="1"

Flame synchronous transfer mode: R channel data is transferred right after L channel data.

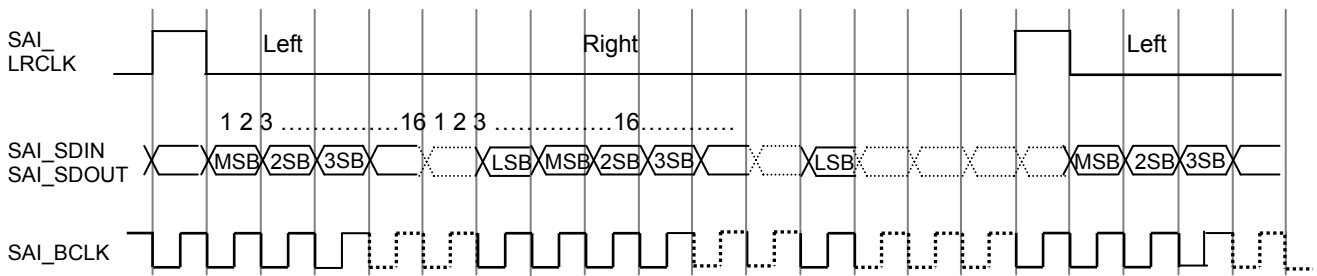

Figure 22

DLYI="1", FMTI="1"

Flame synchronous transfer mode: R channel data is transferred right after L channel data.

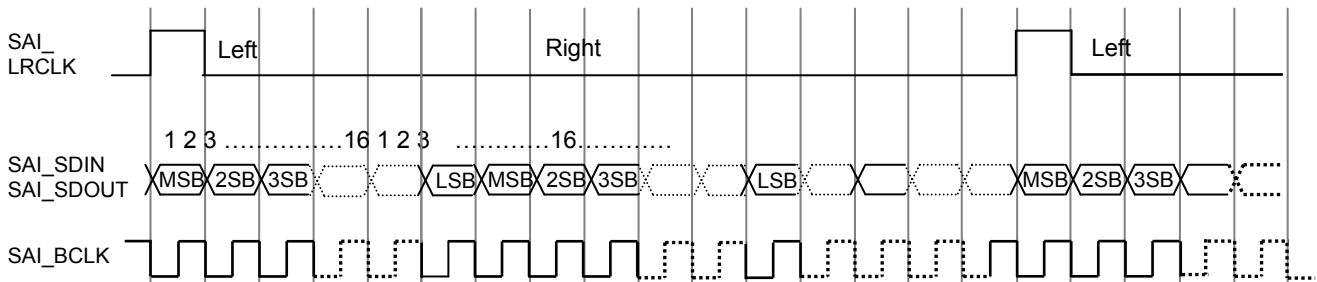

Figure 23

- Related Register
- SAI Transmitter Control Register
- SAI Receiver Control Register

2 wire serial interface

This LSI has 2 wire serial interfaces. The LSI operates as a slave device. The address is fixed at "0011010".

- Format

The followings are the protocol of the LSI.

Write (MSB first)

Start Condition (Set SDA level from "H" to "L" during SCL="H")

Slave Address (0011010) +W (0) (8bit)

Write Address (8bit)

Write Data (8bit)

...

Stop Condition (Set SDA level from "L" to "H" during SCL="H")

Read (MSB first)

Start Condition

Slave Address (0011010) +W (0) (8bit)

Read Address (8bit)

(Stop Condition) Start Condition

Slave Address (0011010) +R (1) (8bit)

Read Data (8bit)

The following shows the wave form of the LSI.

The yellow gridding shows that slave device drives the bus.

The symbol in the wave form means as following table.

Unit	Description
W/R	0: It is Read Write 1
A	0: ACK(Acknowledge) 1: NAK(Not Acknowledge)
A[7-0]	Address (8bit)
D[7-0]	Data(8bit)

Write

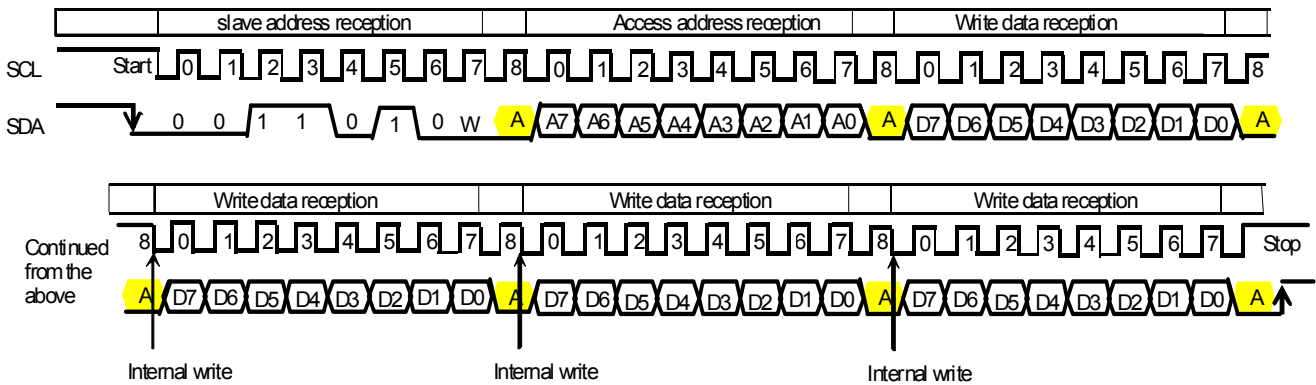

Figure 24

In case there is no Stop or Start condition after internal register is written (Above figure: Internal Write), the slave device becomes continuous write mode and the next received 8 bits of data will be written into the internal register addressed by incremented by two to the current address.

Read

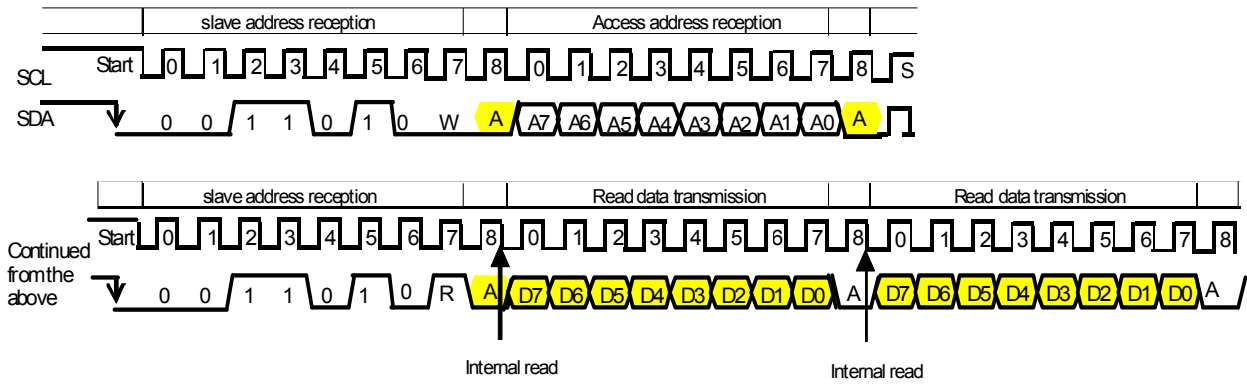

Figure 25

If the Master device returns ACK (acknowledge) after the 8 bit data transferred from the LSI becomes continuous read mode. The next received 8 bits of data will be read from the internal register addressed by incremented by two to the current address.

## State transition about sound control

The following shows state transition about sound control. A change state is carried out by RECPLAY bit setup.

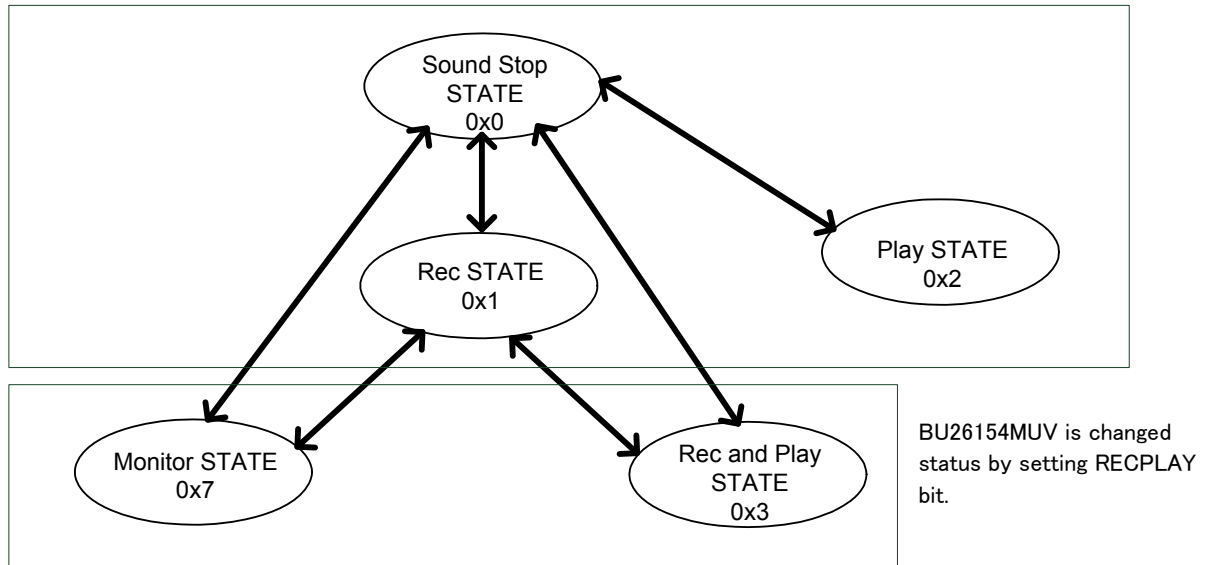

Figure 26

- (1) Sound Stop STATE (RECPLAY=0x0)  
Sound activity is stopped.
- (2) Rec STATE (RECPLAY =0x1)  
Recording is enabled through microphone.
- (3) Play STATE (RECPLAY =0x2)  
Playback is enabled from SAI.
- (4) Monitor STATE (RECPLAY =0x7)  
Monitoring recording via microphone is enabled. ALC function is only effective in recording path.  
Only 2ch sound effects are available in Notch filter mode. In the time of transition Rec STATE to Monitor STATE, please set off the register bits of EQ2EN-EQ3EN.
- (5) Rec and Play STATE (RECPLAY =0x3)  
Playback is enabled from SAI with recording via microphone. ALC function is only effective in recording path.  
Only 2ch sound effects are available in Notch filter mode. In the time of transition Rec STATE to Monitor STATE, please set off the register bits of EQ2EN-EQ3EN.

Signal Flow

It uses signal flow Case1 or Case2 at the time of recording (analog microphone).

Case1:

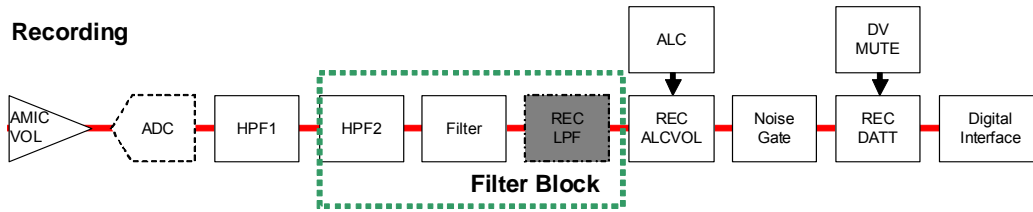

Case2:

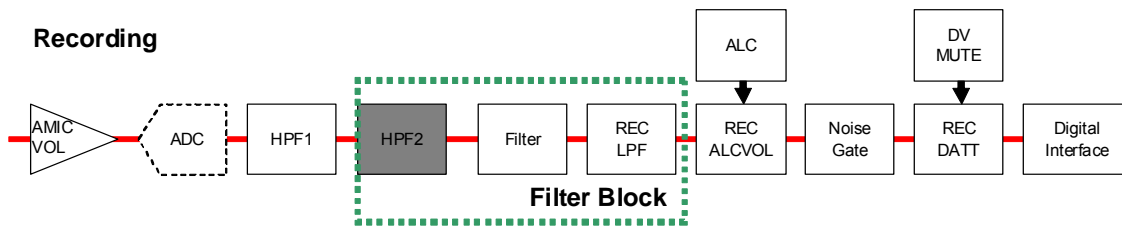

Figure 27

Name	Function	Related Register	Setting
AMICVOL	Analog Microphone volume	Mic input volume control	Volume setting 9dB to +35.25dB
HPF1	High path filter for record DC cut	DSP Filter Function Enable	HPF Enable/Disable
HPF2	High pass Filter for Record	DSP Filter Function Enable	HPF Enable/Disable order setting
Filter	Notch filter is available	High Pass Filter2 Cut-off Control	Cut-off frequency setting
		Sound Effect Mode	Sound Effect mode setting
		DSP Filter Function Enable	Each filters Enable/Disable setting
		EQ Band N Gain Setting	Each filters gain setting
RECLPF	Low pass Filter for recording.	Programmable EQ Band N Coefficient-a0/1	Each sound effects characteristics setting
		Rec Programmable LPF Setting	LPF Enable/Disable setting order setting
		Rec Programmable LPF Cutoff Coef	Cut-off frequency setting
REC ALCVOL	ALC use:ALC controls volume ALC not use: It's available as Boost volume	refer to application note	
ALC	Auto Level Controller Function. ALC is processed to recording data		
Noise Gate	The purpose is for reducing a floor noise		
RECDATT	Record Digital Attenuator. It's available fader function for reducing a Pop-noise when changing volume.	Record Digital Attenuator Control	Record Digital Attenuator Control
		Digital Volume Control Function Enable	Digital Volume Control Function Enable
		Mixer & Volume Control	Mixer & Volume Control
DVMUTE	Record Digital Volume Mute	Digital Volume Control Function Enable	Digital Volume Control Function Enable

\* Please refer to the Sound Effect Mode register for Filter Block. When Filter Block is connected with the reproduction route, nothing is processed in the recording route.

Signal flow at the time of the reproduction

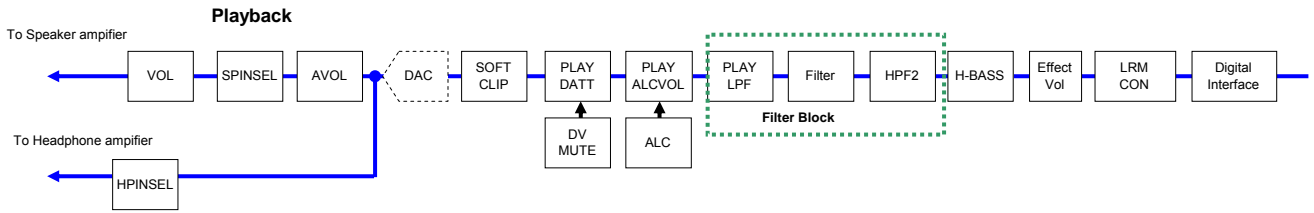

Figure 28

Name	Function	Related Register	Setting
LRMCON	Mixer of the Lch/Rch data input from SAI.	Mixer & Volume Control	Mixer setting
Effect Vol	It is digital before the sound is processed Volume.	Playback Effect Volume	Volume setting -71.5dB to 0dB (0.5dBstep)
P <sup>2</sup> Bass+	Block for P <sup>2</sup> Bass + processing.	P <sup>2</sup> Bass+ Enable P <sup>2</sup> Bass+ Parameter*	Setting of P <sup>2</sup> Bass+
Filter	Notch filter is available	Sound Effect Mode	Sound mode setting
		DSP Filter Function Enable	Enable/Disable of each filter
		EQ Band N Gain Setting	Gain setting of each filter
		Programmable EQ Band N Coefficient-a0/1	Characteristic setting of each filter and acoustic treatment
PLAYLPF	It is programmable LPF for the reproduction.	Play Programmable LPF Setting	Degree setting of LPF for Enable/Disable reproduction of LPF for reproduction
		Play Programmable LPF Cutoff Coef	Characteristic setting of LPF for reproduction
PLAY ALCVOL	When ALC is used It functions as Volume that ALC controls. When ALC unused: It functions as Boost Volume.	Please refer to the application note for the ALC function.	
ALC	It is an auto level controller. ALC is processed to the reproduction data.		
PLAYDATT	Digital Attenuator of the reproduction route. Fader can be used for the noise reduction at the Volume setting change.	Playback Digital Attenuator Control	Volume setting -71.5dB to 0dB (0.5dBstep)
		Digital Volume Control Function Enable	Fader ON/OFF setting (Synchronize with DVMUTE.)
		Mixer & Volume Control	Setting at Fade time (Synchronize with DVMUTE.)
DVMUTE	Reproduction route (PLAYDATT) is compulsorily put into the state of Mute. The value of PLAYDATT need not be changed.	Digital Volume Control Function Enable	MUTE ON/ Turning off setting
SPVOL	The Analog Boost Volume of Speaker amplifier setting.	Speaker Amplifier Input Control	Volume setting 0dB/6dB/12dB/18dB
AVOL	The Analog Volume of reproduction route setting. Fader can be used for the Pop-noise reduction at the Volume setting change.	Analog volume control	Volume setting -28dB to +18dB*At BTL
		Amplifier Volume Fader Control	Fader ON/OFF setting (Synchronize with AVMUTE.)
		Amplifier Volume Control Function Enable	Setting at Fade time (Synchronize with AVMUTE.)
AVMUTE	Reproduction route (SPVOL) is compulsorily put into the state of Mute. The value of SPVOL need not be changed.	Amplifier Volume Control Function Enable	MUTE ON/OFF setting
SPINSEL	It selects the input path to speaker amplifier.	Speaker Amplifier Input Control	Selection of speaker amplifier playback path
HPINSEL	It selects the input path to headphone amplifier.	Headphone Amplifier Input Control	Selection of headphone amplifier playback path

\* Please refer to Sound Effect Mode Register for Filter Block. When Filter Block is connected with the recording route, nothing is processed in the reproduction route.

Filter (5bands-Programmable IIR Filter)

A five bands equalizer features a second-order IIR type Band Pass Filter. Volume control of MUTE, -71.5dB to +12dB (0.5dB step) can be controlled at all paths.

Each channels of the filter can be selected parallel connection or serial connection

The followings are block diagrams at parallel connection and serial connection

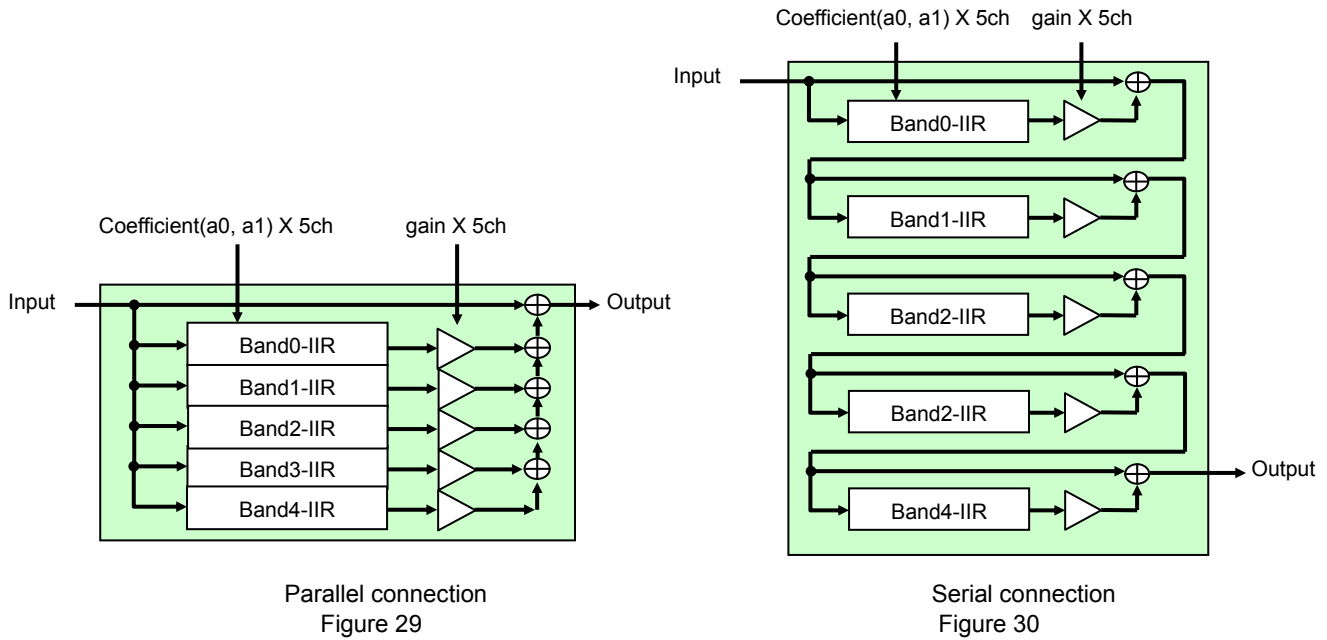

The filter coefficient is programmable. From required center frequency and band width, Programmable Equalizer Coefficient-a0 Control Register and Programmable Notch Filter Coefficient-a1 Control Register value is decided. Followings are the setting formula.

$$a0 = (1 - \tan\pi f_b / fs) / (1 + \tan\pi f_b / fs)$$

$$a1 = -2\cos 2\pi f_0 / fs / (1 + \tan\pi f_b / fs)$$

- f0: Band center frequency [Hz]
- fb: -3dB band width [Hz]
- fs: Sampling frequency [Hz]

\* Actual setting value is an integral number that the result of above formula multiplied by  $2^{14}$  then round up numbers of five and above and round down anything under five to a integer.

DSP filtering function: ON / OFF

DSP Filter Function Enable register can set ON or OFF of each filter function. Please change this register when RECPLAY bit is 0x0. If this register is changed on playback or recording, the noise may be generated.

ALC Auto Level Control

Please refer the application note "AutoLevelControlApplicationNote".

P<sup>2</sup>Bass+ (Perfect Pure Bass Plus)  
Please refer the application note.

Soft clip limiter

Soft clip function is reduced power consumption. If ALC cannot be responded to input waveform, soft clip function is reduced input waveform. In case of input waveform is overed threshold level, soft clip reduce output waveform.

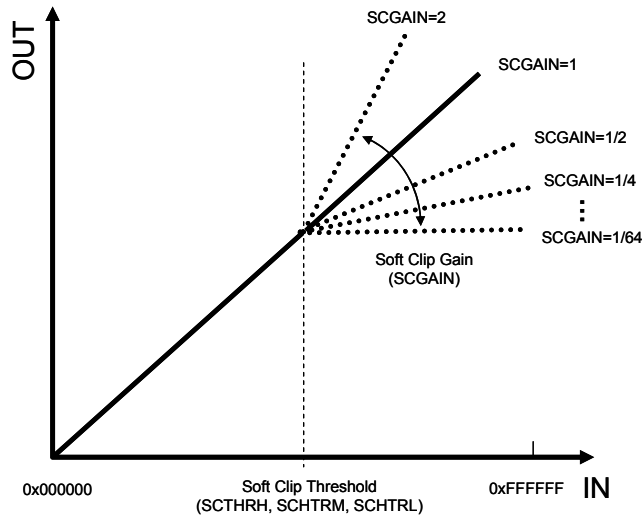

Figure 31

### Low Power Consumption Operation

When PCM data is inputted into LSI consecutive "0" is detected, it will disable the output amplifier automatically and perform low power consumption mode operation by stopping the internal clock. When data except "0" are inputted, it will automatically return to original movement.

When "0" is detected in both LCHRCH, this function is effective. When you use only LCH, please input "0" data into the RCH side. When you use only RCH, please input "0" data into the LCH side. This function is effective only at the time of the playback of the speaker amplifier. At the time of headphones amplifier playback and the recording, please set it to disable. In addition, set the enable function and "0" count level in Zero Detection Setting Register.

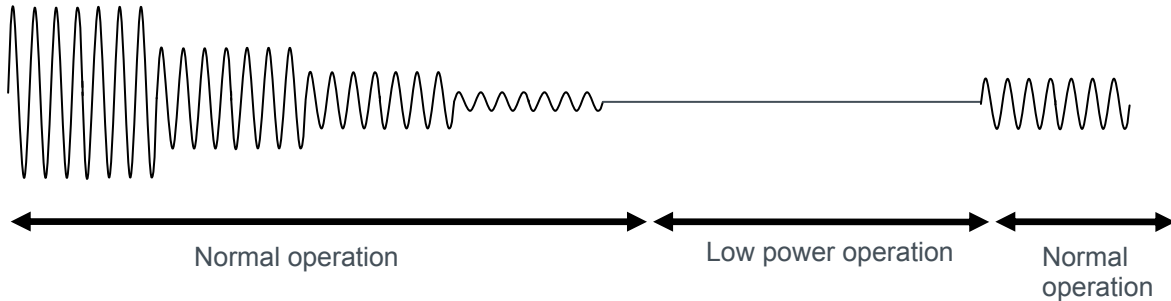

Figure 32

### Change of the SP/HP playback

When it changes of Speaker Amplifier and Headphone Amplifier, it prepares for COEFSEL bit because it does not perform the re-setting of filter coefficients. A side register is used when COEFSEL bit is "0". B side register is used when COEFSEL bit is "1". The target registers are as follows. Please be careful in setting addresses.

A side register		B side register		Register
MAP	INDEX(R)	MAP	INDEX(R)	-
2	0x24/0x26/0x28	2	0x2a/0x2c/0x2e	P <sup>2</sup> BASS+ Parameter0/1/2
0	0x46	2	0x46	Play HPF2 Setting
0	0x4c/0x4e	2	0x4c/0x4e	Play Programmable HPF2L/H Coef
0	0x5c	2	0x5c	Sound Effect Mode
0	0x66	2	0x66	DSP Filter Function Enable
0	0x70	2	0x70	Playback Effect Volume Control
0	0x3e	2	0x73	Playback Digital Attenuator Control
0	0x74 to 0x7c	2	0x74 to 0x7c	EQ Band0/1/2/3/4 Gain Setting
0	0x80 to 0xa6	2	0x7e to 0xa4	Programmable Equalizer Band0/1/2/3/4 Coefficient-a0/a1 L/H

Analog block

VMID is used as analog circuit reference voltage for both recording path and playback path. Therefore, both case for recording and playback, VMID need to do power up. At the power up, the wait time in proportion to the capacitor value is needed to charge external capacitor connected with VMID pin. If recording and playback start before completion of charge, it may generate noise. The following is a sequence of recommendation. Refer to the Analog Reference Power Management Register for the function of VMIDCON.

VMID Power UP/DOWN Sequence (External capacitor 1uF)

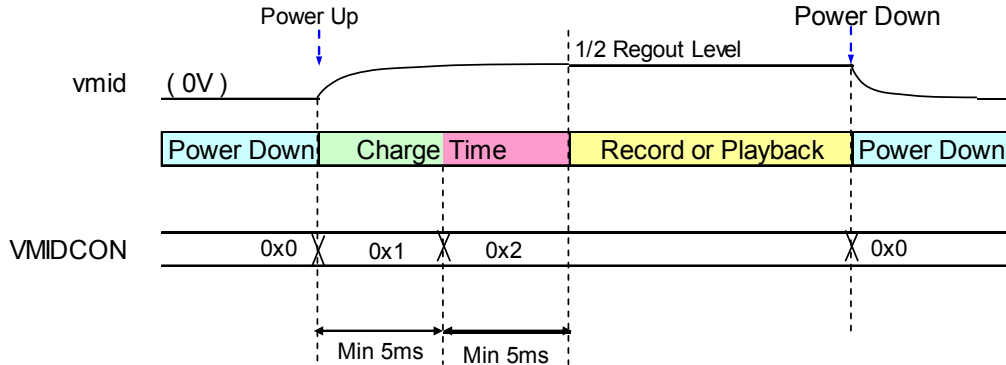

Figure 33

Playback Path

The LSI can be executed sound output from 4 paths bellow. The output can be selected by Speaker Amplifier Output Control Register and Analog Reference Power Management Register.

- Digital Input (SAI) → DAC → D-class Speaker Amplifier
- Digital Input (SAI) → DAC → AB-class Speaker Amplifier
- Digital Input (SAI) → DAC → Headphone Amplifier
- Analog Microphone Input (MIN pin) → ADC → DAC → Headphone Amplifier

<attention>

No guaranty of record path sound quality during speaker amplifier active.

Speaker amplifier

The speaker amplifier of BU26154 can choose operation mode among one of D-class operation or the AB-class operation. It can prevent interference with FM radio influence by making AB-class operation. It performs the change of the enable / disable setting of the speaker amplifier and the AB-class/D-class operation in Speaker Amplifier Power Management Register.

Headphones amplifier

The headphones amplifier of BU26154 operates in a ground reference. Therefore the LSI can delete the condenser for the AC coupling to get outside. In addition, the LSI can suppress a POP noise when you want to suppress a POP noise by connecting the optional resistance of the chart below outside.

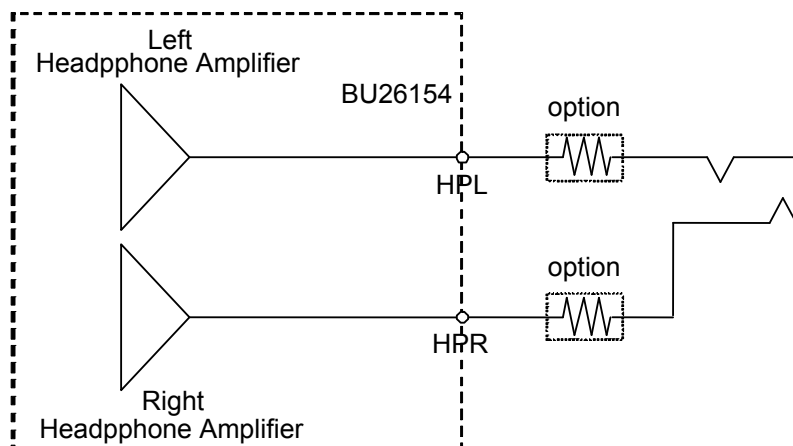

Figure 34

In addition, it is necessary to operate LDO for headphone amplifier when operating headphones amplifier. The power up of headphones amplifier and LDO for headphone set in Analog Reference Power Management Register. Please power up the headphones amplifier after 1mS waiting time for LDO for headphones. At the time of the power down, please power down HPVDD after the power down of the headphones amplifier.

HPVDD Power UP/DOWN Sequence

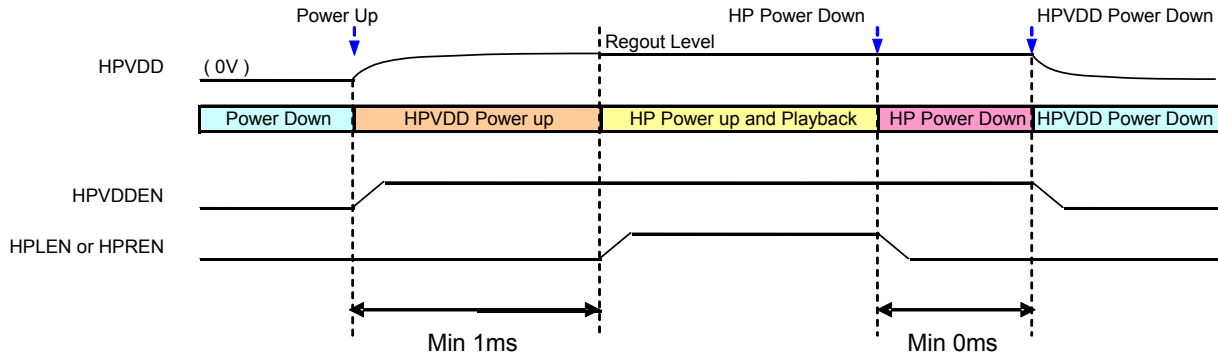

Figure 35

About HPCOM pin

HPCOM pin is a signal ground pin of the headphones amplifier.

### Microphone amplifier

The microphone input can support two modes, a single-end and differential. When using it in single-end input, it writes "0" in the MINDIF bit of the MIC Interface Control register. When using differential input, it writes "1". In the case of single-end input, it can input from MINP pin or MINN pin. Please set of the input pin in MIC Select Control Register.

### Microphone bias

The Case of using Microphone bias, it shows a recommended connection diagram. By all means, please connect a condenser (2.2uF at the minimum) to MBIASCAP outside pin. On this occasion, the LSI can improve noise characteristics by connecting the option resistance on the chart below (the optional resistance is up to 50 Ω).

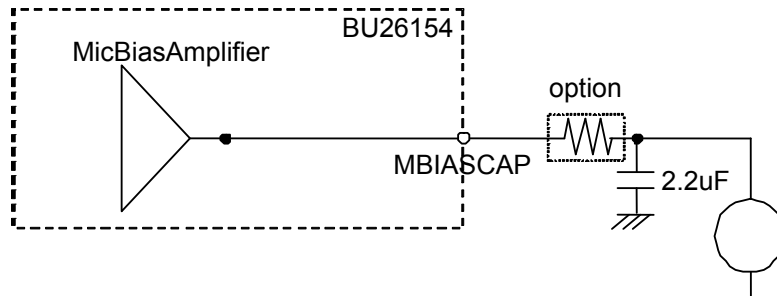

Figure 36

In addition, according to the capacity of the outside condenser, it is necessary to wait until microphone bias is stable. In waiting time of MICBIAS, please set the value of the MICTIME bit at the MIC Input Charging Time register.

Touch Screen Controller

SAR 12 bits ADC is integrated into this LSI and is available as 4 lines type touch screen controller.

There is the function of the X-axis, the position sensing of the Y-axis, the pen pressure detection and the pen interrupt detection.

It becomes independent to Codec and is controllable without minding timing. But the hard reset (reset signal input by RESETB pin) communizes it.

Clock control

When enabled clock is to be used for touch screen controller, set TCLKEN bit of Clock Enable Register to "1". The touch screen controller function uses a built-in oscillator. Therefore it is not necessary to perform clock control listing in item clock control when using only the touch screen controller.

Position sensing

This LSI is available for the position sensing of the touch screen. The twice measurement of the X-axis measurement, the Y-axis measurement is necessary for position sensing.

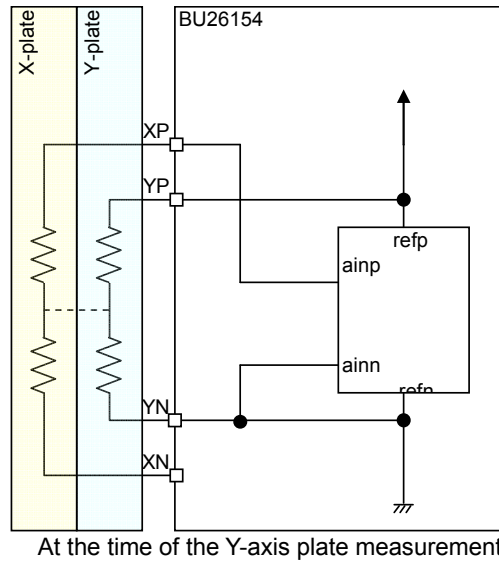
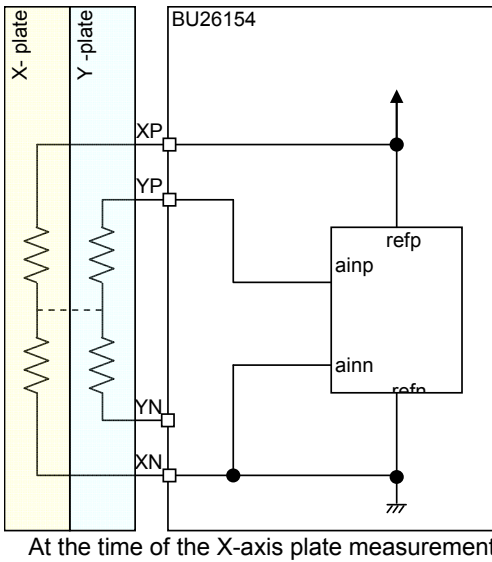

Figure 37

The Pen Pressure Detection

The measurement of touch pressure is carried out to measure the resistance between X plate and Y plate. It is calculable by two methods, from the location information by location determination, and the measurement result in touch pressure measurement mode.

In case of X-Position and Y-Position are known

$$\text{Touch pressure resistance} = X\text{-plate resistance} \cdot (X\text{-position}/4096) \cdot [(4096/Z1) - 1] - Y\text{-plate resistance} \cdot [1 - (Y\text{-position}/4096)]$$

In case of X-Position is known

$$\text{Touch pressure resistance} = X\text{-plate resistance} \cdot (X\text{-position}/4096) \cdot [(Z2/Z1) - 1]$$

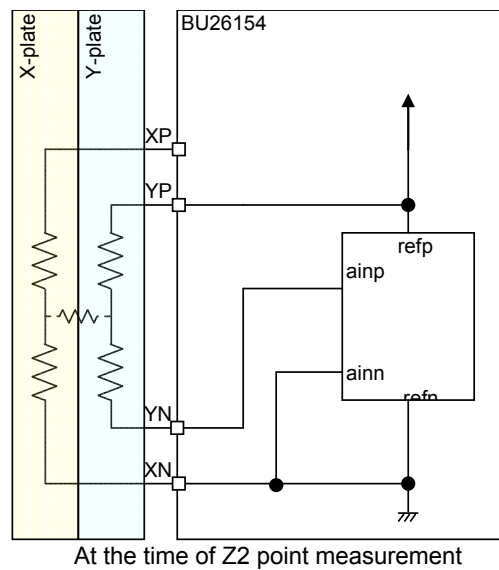
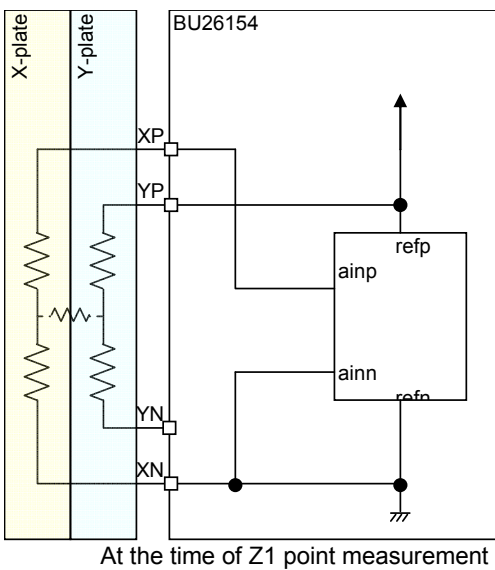
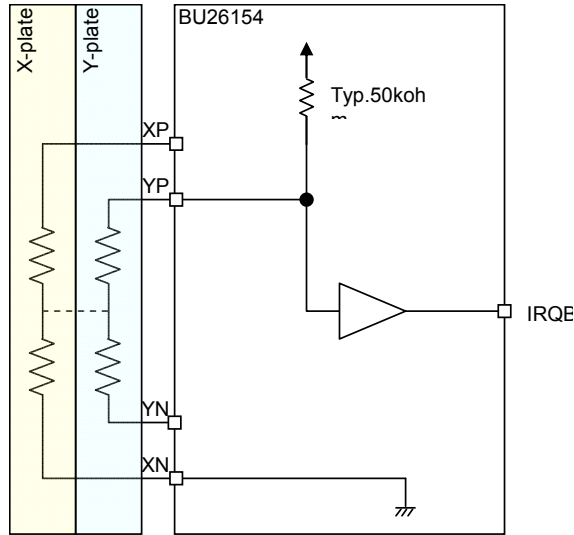

Figure 38

The Pen Interrupt Detection

Touch detect function outputs the X-plate and Y-plate contact from IRQB pin. Please refer to Description of Registers for valid or invalid setup of Touch Detection. When X-plate and Y-plate do not contact, H level is outputted from IRQB pin by internal pull-up resistor (typical 10kohm). When X-plate and Y-plate contact, L level is outputted from IRQB pin by touch plate resistance (about hundreds ohm). Please refer to Description of Registers for IRQB output selection. Touch Detect schematic diagram is shown below.



Interrupt detect circuit  
Figure 39

IRQB pin outputs "L" during RESETB "L"(RESET state) period. During this period, please mask interrupt.

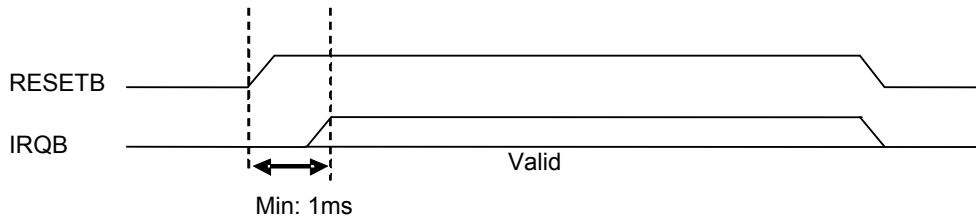

Interrupt timing  
Figure 40

#### About Touch Panel Interface at Interrupt Wait

Touch panel interface can switch to low power consumption by stopping the operation of unnecessary circuits at interrupt wait.

#### Setting of touch panel interface at interrupt wait

0x2d = 0x00, // Thermal detect circuit Disable  
0x1d = 0x02, // MAPCON=2  
0x05 = 0x22, // Level shifter for headphone OFF  
0x13 = 0x00, // Reference current circuit for audio system OFF  
0x1d = 0x00, // MAPCON=0  
0x0d = 0x80, // Touch panel interface oscillation circuit Enable  
0x1d = 0x01, // MAPCON=1  
0x61 = 0x38, // Touch panel interface interrupt circuit Enable  
0x1d = 0x00, // MAPCON=0  
0x0d = 0x00, // Touch panel interface oscillation circuit Disable

This state is interrupt wait mode. Please use a touch panel interface after interrupt, setting enable oscillation circuit.

Please, set circuit from Disable to Enable in circuit when using of audio system function

#### Setting at using of audio system function

0x2d = 0x01, // Thermal detect circuit Enable  
0x1d = 0x02, // MAPCON=2  
0x05 = 0x26, // Level shifter for headphone ON  
0x13 = 0x01, // Reference current circuit for audio system ON  
0x1d = 0x00, // MAPCON=0

Operating Mode

Normal operating mode

It becomes Normal operating mode by setting Touch ADC Control register TCHA2=0x1. Next AD conversion starts by reading register value of ADCR1 register (8Bit mode) or ADCR2 register (12Bit mode), at Normal operating mode.

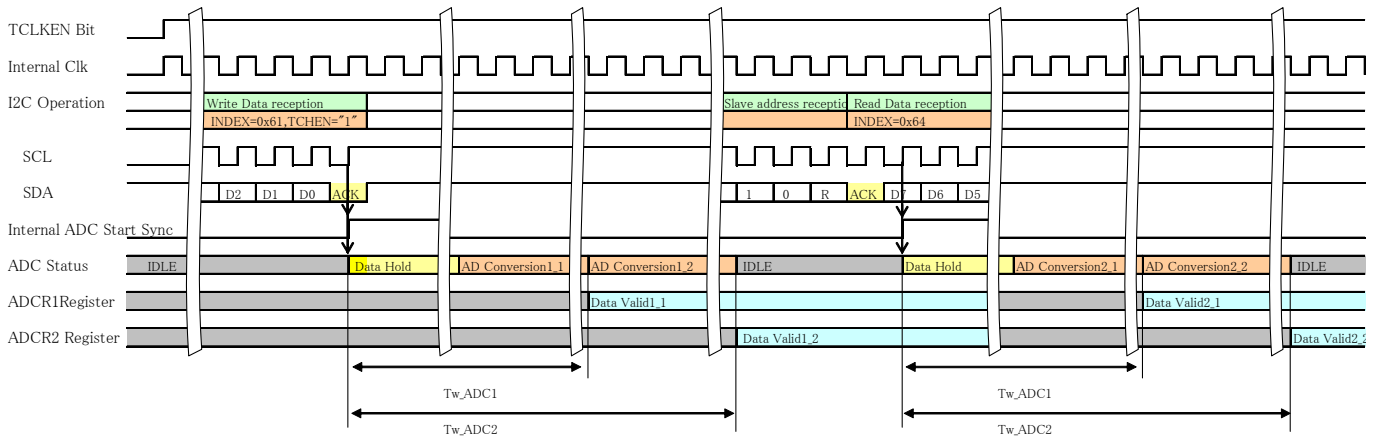

12Bit Normal Mode I2C Timing

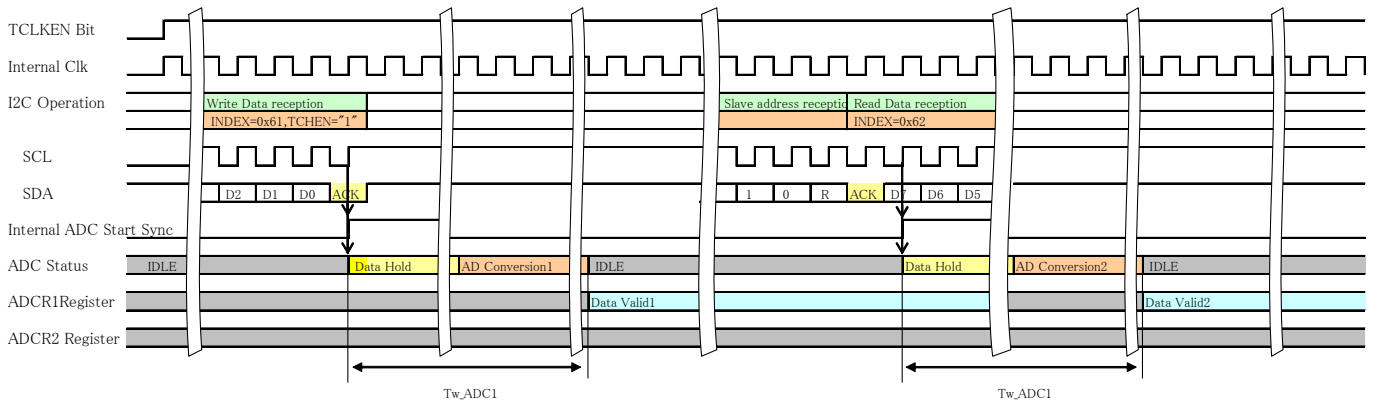

8Bit Normal Mode I2C Timing

AD conversion starts by rising edge of CSB at using SPI. 12Bit timing mode chart is listed below. 8Bit mode start timing is similar it.

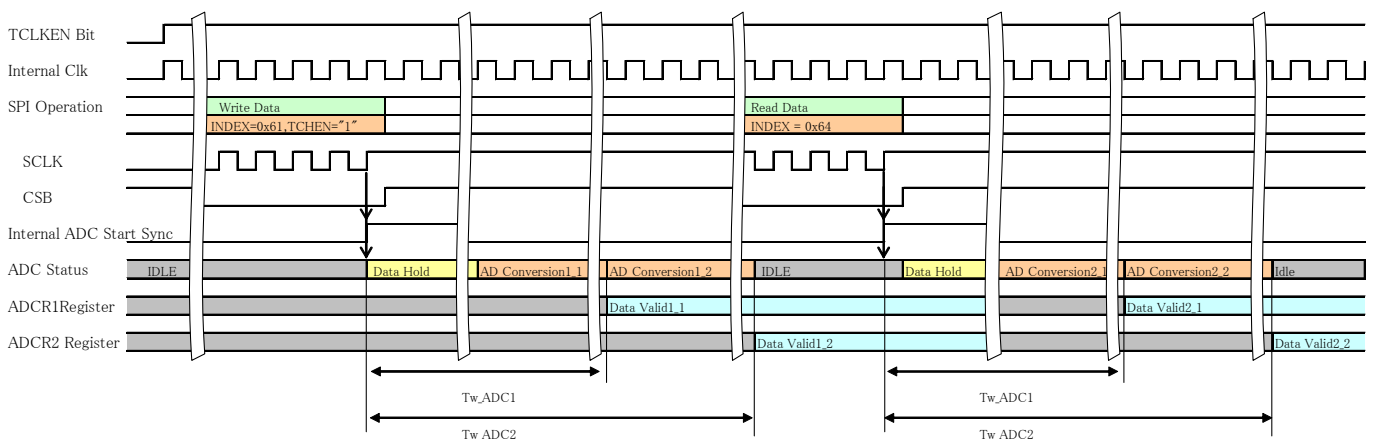

8Bit Normal Mode SPI Timing

Auto Operation Mode

When TCHA2 bit of Touch ADC Control register is set to "0", BU26154MUV is set to Auto Operation Mode. When is to set in Auto Mode Operation, BU 26154 MUV is Interrupt mode by reading to ADCR2 register in 12 bit mode and BU 26154 MUV is Interrupt mode by reading to ADCR1 register in 8 bit mode.

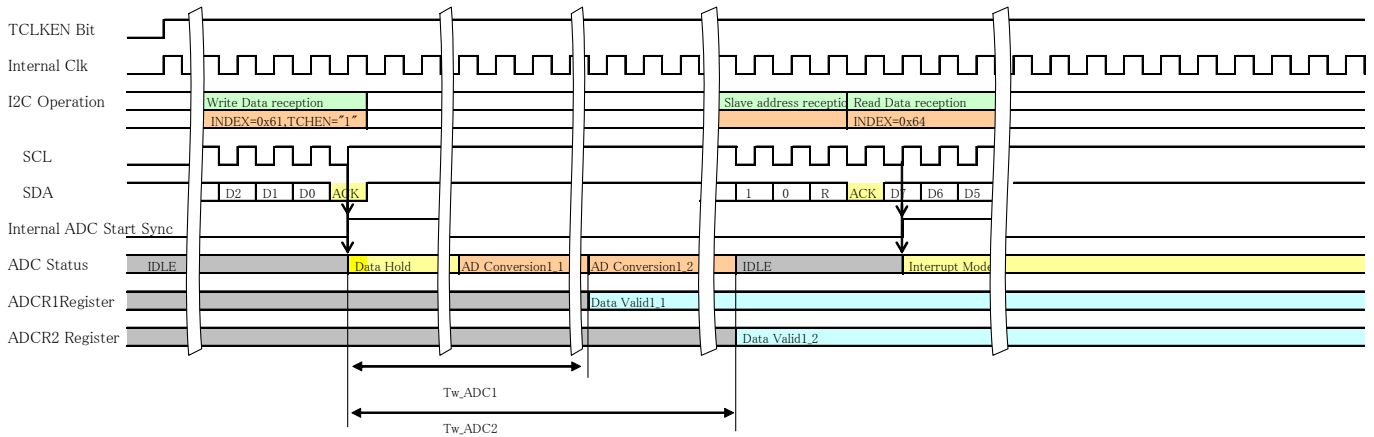

12Bit Auto Mode I2C Timing

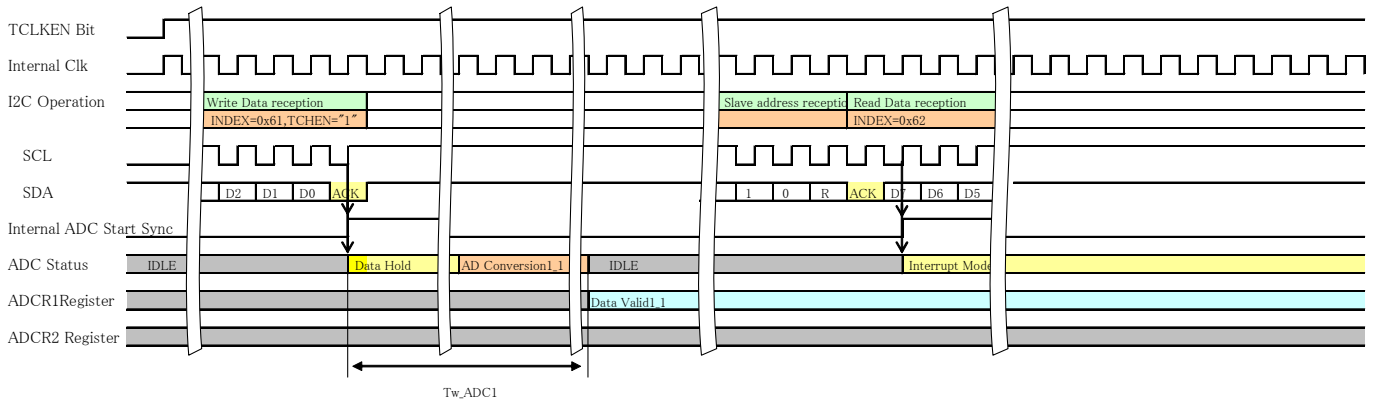

8Bit Auto Mode I2C Timing

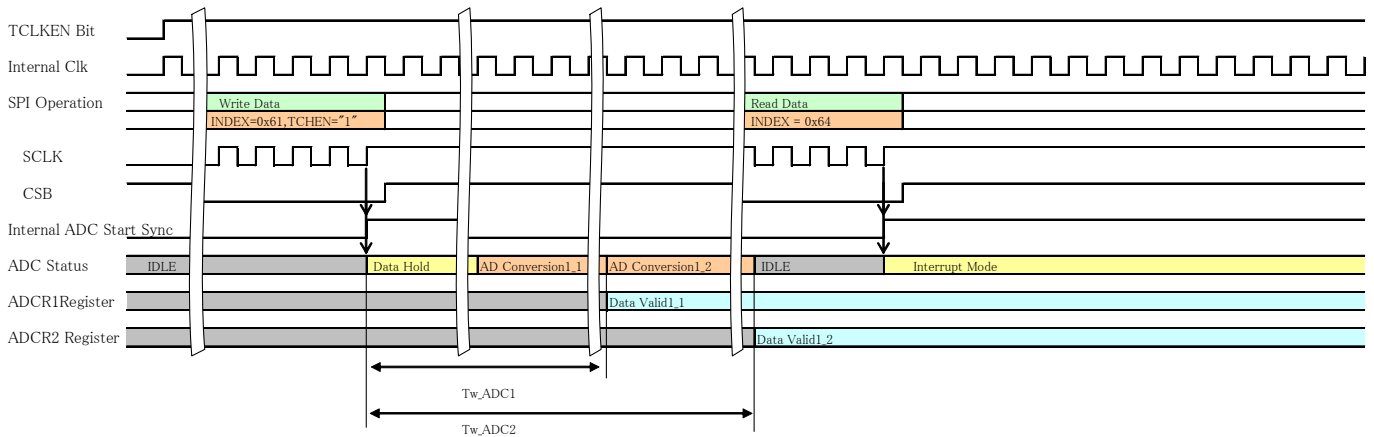

12Bit Auto Mode SPI Timing

## Register function explanation

### Register map

Note: “-” indicates a reserved bit. They return “0” for read. Write “0” to the bit every time. If “1” is written to this bit, the operations cannot be guaranteed.

Don't write data to empty INDEX or register bit to guarantee normal operation.

A function with (\*)bit doesn't need internal clock to change state.

The following registers are accessible at the time of MAPCON=0x0 of the Register Map Control register (0x1c/0x1d).

INDEX		b07	b06	b05	b04	b03	b02	b01	b00	Register Name	Note	
R	W	(Initial)										
0x00	0x01	-	-	-	-	SR				Sampling Rate Setting		
		-	-	-	-	0	0	0	0			
0x0c	0x0d	TCLKEN	-	-	-	-	PLLOE	PLLEN	MCLKEN	Clock Enable		
		0	-	-	-	-	0	0	0			
0x0e	0x0f	-	-	-	PLLISEL		CLKSEL			Clock Input/Output Control		
		-	-	-	0	0	0	0	0			
0x10	0x11	-	-	-	-	-	-	-	SOFTRST	Software Reset		
		-	-	-	-	-	-	-	0			
0x12	0x13	-	-	-	-	-	RECPLOY			Record/Playback Running Control		
		-	-	-	-	-	0	0	0			
0x14	0x15	-	-	MCTIME						Mic Input Charging Time		
		-	-	0	0	0	0	0	0			
0x1c	0x1d	-	-	-	-	-	MAPCON			Register MAP Control		
		-	-	-	-	-	-	-	0			
0x20	0x21	HPREN	HPLEN	-	-	HPVDDEN	MICBEN	VMIDCON			Analog Reference Power Management	
		0	0	-	-	0	0	0	0			
0x22	0x23	-	-	PGAATT	-	PGAEN	-	ADCEN	-	Analog Input Power Management		
		-	-	0	-	0	-	0	-			
0x24	0x25	-	-	-	-	-	DACREN	DACLIN	-	DAC Power Management		
		-	-	-	-	-	0	0	-			
0x26	0x27	SPMDSEL	-	-	AVREN	COEFSEL	-	SPEN	AVLEN	Speaker Amplifier Power Management		
		0	-	-	0	0	1	0	0			
0x2c	0x2d	-	-	-	-	-	-	-	TSDEN	Thermal Shutdown Control		
		-	-	-	-	-	-	-	1			
0x2e	0x2f	-	-	-	-	-	-	ZCEN	-	Zero Cross Comparator Power Management	note1	
		-	-	-	-	-	-	0	-			
0x30	0x31	-	-	-	-	-	-	MICBCON		MICBIAS Voltage Control		
		-	-	-	-	-	-	0	0			
0x3a	0x3b	-	-	-	AVVOL					Analog Volume Control		
		-	-	-	0	1	0	1	0			
0x3e	0x3f	PDATT								Playback Digital Attenuator Control		
		1	1	1	1	1	1	1	1			
0x46	0x47	-	-	HPF2CSEL	PLHPF2CUT			PLHPF2OD	PLHPF2EN	Play HPF2 Setting		
		-	-	0	0	0	0	0	0			
0x48	0x49	-	-	-	-	-	-	AVMUTE	AVFADE	Amplifier Volume Control Function Enable		
		-	-	-	-	-	-	0	0			
0x4a	0x4b	-	-	-	-	-	-	AVFCON			Amplifier Volume Fader Control	
		-	-	-	-	-	-	0	0			
0x4c	0x4d	PHPF2C0L								Play Programmable HPF2 CoefL		
		0	0	0	0	0	0	0	0			
0x4e	0x4f	PHPF2C0H								Play Programmable HPF2 CoefH		
		0	0	0	0	0	0	0	0			
0x58	0x59	-	-	OSRSEL		-	-	-	-	DAC Clock Setting		
		-	-	0	0	-	-	-	-			
0x5a	0x5b	MINVOL			-	-	-	MINDIF	-	Mic Interface Control		
		1	0	0	-	-	-	0	-			
0x5c	0x5d	SEMODE[7]	-	-	-	-	SEMODE[2:0]				Sound Effect Mode	
		0	-	-	-	-	0	0	0			
0x60	0x61	PCMFO24		FMT0	MSB0	ISSCK0	AFOO	DLY0	WSLO	SAI Transmitter Control		
		1	1	0	0	0	0	0	0			
0x62	0x63	PCMF124		FMTI	MSBI	ISSCKI	AFOI	DLYI	WSLI	SAI Receiver Control		
		1	1	0	0	0	0	0	0			
0x64	0x65	-	-	-	BSWP	-	-	-	MST	SAI Mode select		
		-	-	-	0	-	-	-	0			
0x66	0x67	HPF2OD	EQ4EN	EQ3EN	EQ2EN	EQ1EN	EQ0EN	HPF2EN	HPF1EN	DSP Filter Function Enable		
		0	0	0	0	0	0	0	1			
0x68	0x69	-	-	-	DVMUTE	DVFADE	-	RALCEN	PALCEN	Digital Volume Control Function Enable		
		-	-	-	0	0	-	0	0			
0x6a	0x6b	DVFCON			RMCON		LMCON			Mixer & Volume Control		
		0	0	0	0	0	0	0	0			
0x6c	0x6d	RDVOL								Record Digital Attenuator Control		
		1	1	1	1	1	1	1	1			
0x70	0x71	Effect VOL								Playback Effect Volume Control		
		1	1	1	1	1	1	1	1			
0x72	0x73	-	RALCVOL						-	-	Record ALC Volume Control	note1
		-	0	1	0	0	0	0	0			
0x74	0x75	EQGAIN0								EQ Band0 Gain Setting		
		1	1	1	0	0	1	1	1			

INDEX		b07 (Initial)	b06	b05	b04	b03	b02	b01	b00	Register Name	Note	
R	W											
0x76	0x77	EQGAIN1								EQ Band1 Gain Setting		
		1	1	1	0	0	1	1	1			
0x78	0x79	EQGAIN2								EQ Band2 Gain Setting		
		1	1	1	0	0	1	1	1			
0x7a	0x7b	EQGAIN3								EQ Band3 Gain Setting		
		1	1	1	0	0	1	1	1			
0x7c	0x7d	EQGAIN4								EQ Band4 Gain Setting		
		1	1	1	0	0	1	1	1			
0x7e	0x7f	-	-	-	-	-	HPF2CUT			High Pass Filter2 Cut-off Control		
		-	-	-	-	-	0	0	0			
0x80	0x81	EQ0A0L								Programable Equalizer Band0 Coefficient-a0 (L)		
		0	0	0	0	0	0	0	0			
0x82	0x83	EQ0A0H								Programable Equalizer Band0 Coefficient-a0 (H)		
		0	0	0	0	0	0	0	0			
0x84	0x85	EQ0A1L								Programable Equalizer Band0 Coefficient-a1 (L)		
		0	0	0	0	0	0	0	0			
0x86	0x87	EQ0A1H								Programable Equalizer Band0 Coefficient-a1 (H)		
		0	0	0	0	0	0	0	0			
0x88	0x89	EQ1A0L								Programable Equalizer Band1 Coefficient-a0 (L)		
		0	0	0	0	0	0	0	0			
0x8a	0x8b	EQ1A0H								Programable Equalizer Band1 Coefficient-a0 (H)		
		0	0	0	0	0	0	0	0			
0x8c	0x8d	EQ1A1L								Programable Equalizer Band1 Coefficient-a1 (L)		
		0	0	0	0	0	0	0	0			
0x8e	0x8f	EQ1A1H								Programable Equalizer Band1 Coefficient-a1 (H)		
		0	0	0	0	0	0	0	0			
0x90	0x91	EQ2A0L								Programable Equalizer Band2 Coefficient-a0 (L)		
		0	0	0	0	0	0	0	0			
0x92	0x93	EQ2A0H								Programable Equalizer Band2 Coefficient-a0 (H)		
		0	0	0	0	0	0	0	0			
0x94	0x95	EQ2A1L								Programable Equalizer Band2 Coefficient-a1 (L)		
		0	0	0	0	0	0	0	0			
0x96	0x97	EQ2A1H								Programable Equalizer Band2 Coefficient-a1 (H)		
		0	0	0	0	0	0	0	0			
0x98	0x99	EQ3A0L								Programable Equalizer Band3 Coefficient-a0 (L)		
		0	0	0	0	0	0	0	0			
0x9a	0x9b	EQ3A0H								Programable Equalizer Band3 Coefficient-a0 (H)		
		0	0	0	0	0	0	0	0			
0x9c	0x9d	EQ3A1L								Programable Equalizer Band3 Coefficient-a1 (L)		
		0	0	0	0	0	0	0	0			
0x9e	0x9f	EQ3A1H								Programable Equalizer Band3 Coefficient-a1 (H)		
		0	0	0	0	0	0	0	0			
0xa0	0xa1	EQ4A0L								Programable Equalizer Band4 Coefficient-a0 (L)		
		0	0	0	0	0	0	0	0			
0xa2	0xa3	EQ4A0H								Programable Equalizer Band4 Coefficient-a0 (H)		
		0	0	0	0	0	0	0	0			
0xa4	0xa5	EQ4A1L								Programable Equalizer Band4 Coefficient-a1 (L)		
		0	0	0	0	0	0	0	0			
0xa6	0xa7	EQ4A1H								Programable Equalizer Band4 Coefficient-a1 (H)		
		0	0	0	0	0	0	0	0			
0xb2	0xb3	-	-	-	-	-	RALCATK			Record ALC Attack Time Control	note1	
		-	-	-	-	0	0	1	0			
0xb4	0xb5	-	-	-	-	-	RALCDCY			Record ALC Decay Time Control	note1	
		-	-	-	-	0	0	1	1			
0xb8	0xb9	-	-	-	-	-	RALCLVL			Record ALC Target Level Control	note1	
		-	-	-	1	0	1	1	1			
0xba	0xbb	-	-	-	-	-	RALCMINGAIN			Record ALC Min Gain Control	note1	
		-	-	-	-	-	0	0	0			
0xbc	0xbd	RSATEN	RSATMINGAIN								Record ALC Saturation Detect Control	
		0	0	1	0	0	0	1	0			
0xbe	0xbf	-	-	-	-	-	RALCZCTM			Record ALC Zero Cross Time Out Control	note1	
		-	-	-	-	-	-	0	0			
0xc0	0xc1	-	-	-	-	-	PALCATK			Playback ALC Attack Time Control	note1	
		-	-	-	-	0	1	0	0			
0xc2	0xc3	-	-	-	-	-	PALCDCY			Playback ALC Decay Time Control	note1	
		-	-	-	-	0	1	0	1			

INDEX		b07 (Initial)	b06	b05	b04	b03	b02	b01	b00	Register Name	Note
R	W										
0xc4	0xc5	-	-	-	PALCLVL					Playback ALC Target Level Control	note1
		-	-	-	1	1	0	1	1		
0xc6	0xc7	-	-	-	-	-	PALCMINGAIN			Playback ALC Min Gain Control	note1
		-	-	-	-	-	0	0	0		
0xc8	0xc9	-	PALCVOL						Playback ALC Volume Control	note1	
		-	0	1	0	0	0	0			0
0xca	0xcb	-	-	-	-	-	PALCZCTM		Playback ALC ZeroCross TimeOut	note1	
		-	-	-	-	-	0	0			
0xcc	0xcd	RALCFRTH			RALCFREN		-	RALCFRSP		ALC Fast Release Setting	note1
		0	0	0	1	0	-	0	1		
0xce	0xcf	PALCFRTH			PALCFREN		-	PALCFRSP		Playback Limiter Fast Release Setting	note1
		0	0	0	1	0	-	0	1		
0xdc	0xdd	ZDTIME				-	-	-	ZDEN	Zero Detection Setting	
		0	0	0	0	-	-	-	0		
0xe8	0xe9	-	-	-	-	-	-	MIN2EN	MIN1EN	MIC select Control	
		-	-	-	-	-	-	0	1		

The following registers are accessible at the time of MAPCON=0x1 of the Register Map Control register (0x1c/0x1d).

INDEX		b07	b06	b05	b04	b03	b02	b01	b00	Register Name	Note	
R	W	(Initial)										
0x02	0x03	-	-	-	-	-	FPLL M			FPLL M setting		
		-	-	-	-	-	0	0	0			
0x04	0x05	FPLLNL								FPLL N Setting(L)		
		0	0	0	0	0	0	0	0			
0x06	0x07	-	-	-	-	-	-	-	FPLLNH	FPLL N Setting(H)		
		-	-	-	-	-	-	-	0			
0x08	0x09	-	-	-	FPLLD					FPLL D Setting		
		-	-	-	0	0	0	0	0			
0x0a	0x0b	FPLLF								FPLL F Setting(L)		
		0	0	0	0	0	0	0	0			
0x0c	0x0d	FPLLFH								FPLL F Setting(H)		
		0	0	0	0	0	0	0	0			
0x0e	0x0f	FPLLFDL								FPLL F_D Setting(L)		
		0	0	0	0	0	0	0	0			
0x10	0x11	FPLLFDH								FPLL F_D Setting(H)		
		0	0	0	0	0	0	0	0			
0x12	0x13	-	-	-	-	FPLLV					FPLL V setting	
		-	-	-	-	0	0	0	0			
0x1c	0x1d	-	-	-	-	-	MAPCON			RegisterMAP Control		
		-	-	-	-	-	0	0				
0x20	0x21	-	-	-	-	-	-	-	SCEN	Soft Clip Enable		
		-	-	-	-	-	-	-	0			
0x22	0x23	-	SCTHRH								Soft Clip Threshold H	
		-	0	0	0	0	0	0	0			
0x24	0x25	-	SCTHRM								Soft Clip Threshold M	
		0	0	0	0	0	0	0	0			
0x26	0x27	-	SCTHRL								Soft Clip Threshold L	
		0	0	0	0	0	0	0	0			
0x28	0x29	-	-	-	-	-	SCGAIN				Soft Clip Gain	
		-	-	-	-	-	0	0	1			
0x60	0x61	TCHSEN	TCHA2	TCHA1	TCHA0	-	TCHRSEL	TCHMODE	-	Touch ADC Control		
		0	1	1	1	1	0	0	-			
0x62	0x63	ADCR1								Touch ADC result1		
		0	0	0	0	0	0	0	0			
0x64	0x65	ADCR2				-	-	-	-	-	Touch ADC result2	
		0	0	0	0	-	-	-	-			
0x82	0x83	-	-	HPRIN2EN	HPRIN1EN	-	-	-	HPLIN1EN	Headphone input Select Control		
		-	-	0	0	-	-	-	0			
0x84	0x85	-	-	-	-	SPIN2EN	SPIN1EN	SPVOL			SPAMP input Control	
		-	-	-	-	0	0	0	0			
0xa0	0xa1	-	-	-	-	-	-	PLPFOD	PLPFEN	Play Programmable LPF Setting		
		-	-	-	-	-	-	0	0			
0xa2	0xa3	PLPFC0L								Play Programmable LPF Coef (L)		
		0	0	0	0	0	0	0	0			
0xa4	0xa5	PLPFC0H								Play Programmable LPF Coef (H)		
		0	0	0	0	0	0	0	0			
0xa6	0xa7	-	-	-	-	-	-	RLPFOD	RLPFEN	Rec Programmable LPF Setting		
		-	-	-	-	-	-	0	0			
0xa8	0xa9	RLPFC0L								Rec Programmable LPF Coef (L)		
		0	0	0	0	0	0	0	0			
0xaa	0xab	RLPFC0H								Rec Programmable LPF Coef (H)		
		0	0	0	0	0	0	0	0			
0xda	0xdb	-	-	-	-	-	-	-	NGEN	Noise Gate Setting	note1	
		-	-	-	-	-	-	-	0			
0xde	0xdf	NGMINGAIN								Noise Gate Minimum Gain	note1	
		1	1	0	1	0	0	1	1			
0xe0	0xe1	-	-	NGTH					NGTH		Noise Gate Threshold	note1
		-	-	0	1	0	0	1	0			
0xe2	0xe3	-	-	-	-	-	NGTHHYS			Noise Gate Threshold Hysteresis	note1	
		-	-	-	-	-	0	1	0			
0xe4	0xe5	-	NGSLOPE								Noise Gate Slope	note1
		-	0	0	1	0	1	0	0			
0xe6	0xe7	-	-	-	-	-	-	NGGAINSTEP		Noise Gate Gain Step	note1	
		-	-	-	-	-	-	1	0			
0xe8	0xe9	-	NGENVAVE			-	NGZTIM			Noise Gate Time Setting	note1	
		-	0	0	1	-	0	0	0			

INDEX		b07	b06	b05	b04	b03	b02	b01	b00	Register Name	Note
R	W	(Initial)									
0xea	0xeb	NGFDOUT				NGFDIN				Noise Gate Fade Control	note1
		0	0	0	1	0	1	0	1		
0xec	0xed	NGENVMONL[7:0]								Noise Gate Envelope Monitor Lch(L)	note1
		0	0	0	0	0	0	0	0		
0xee	0xef	NGENVMONL[15:8]								Noise Gate Envelope Monitor Lch(H)	note1
		0	0	0	0	0	0	0	0		
0xf0	0xf1	NGENVMONR[7:0]								Noise Gate Envelope Monitor Rch(L)	note1
		0	0	0	0	0	0	0	0		
0xf2	0xf3	NGENVMONR[15:8]								Noise Gate Envelope Monitor Rch(H)	note1
		0	0	0	0	0	0	0	0		
0xf4	0xf5	NKGAINMON								Noise Gate Gain Monitor	note1
		0	0	0	0	0	0	0	0		

The following registers are accessible at the time of MAPCON=0x2 of the Register Map Control register (0x1c/0x1d).

INDEX		b07 (Initial)	b06	b05	b04	b03	b02	b01	b00	Register Name	Note
R	W										
0x00	0x01	-	-	-	-	-	-	-	EXMODE	PLL External Components Setting Register	
		-	-	-	-	-	-	-	1		
0x04	0x05	-	-	-	-	-	HPLSEN	-	-	Audio Analog Control2	
		-	-	1	-	-	1	1	-		
0x12	0x13	-	-	-	-	-	-	-	AREF1EN	Audio Analog Contr1	
		-	-	-	-	-	-	-	1		
0x1c	0x1d	-	-	-	-	-	-	-	MAPCON	RegisterMAP Control	
		-	-	-	-	-	-	0	0		
0x24	0x25	P2BLPF1A				P2BHPF1A				P2 Bass+ Parameter0A	
		0	0	0	0	0	0	0	0		
0x26	0x27	P2BGAINBSA				P2BLPF2A				P2 Bass+ Parameter1A	
		-	0	0	0	0	0	0	0		
0x28	0x29	P2BGAINEVA				P2BGAINODA				P2 Bass+ Parameter2A	
		0	0	0	0	0	0	0	0		
0x2a	0x2b	P2BLPF1B				P2BHPF1B				P2 Bass+ Parameter0B	
		0	0	0	0	0	0	0	0		
0x2c	0x2d	P2BGAINBSB				P2BLPF2B				P2 Bass+ Parameter1B	
		-	0	0	0	0	0	0	0		
0x2e	0x2f	P2BGAINEB				P2BGAINODB				P2 Bass+ Parameter2B	
		0	0	0	0	0	0	0	0		
0x04	0x05	-	-	-	-	-	HPLSEN	-	-	Audio Analog Control2	
		-	-	1	-	-	1	1	-		
0x12	0x13	-	-	-	-	-	-	-	AREF1EN	Audio Analog Contr1	
		-	-	-	-	-	-	-	1		
0x1c	0x1d	-	-	-	-	-	-	-	MAPCON	RegisterMAP Control	
		-	-	-	-	-	-	0	0		
0x46	0x47	-	-	HPF2CSELB	PLHPF2CUTB			PLHPF2ODB	PLHPF2ENB	Play HPF2B	
		-	-	0	0	0	0	0	0		
0x4c	0x4d	PHPF2C0LB								Play Programmable HPF2 CoefL B	
		0	0	0	0	0	0	0	0		
0x4e	0x4f	PHPF2C0HB								Play Programmable HPF2 CoefH B	
		0	0	0	0	0	0	0	0		
0x5c	0x5d	SEMODE[7]	-	-	-	-	SEMODE[2:0]			Sound Effect Mode B	
		0	-	-	-	-	0	0	0		
0x66	0x67	HPF2ODB	EQ4ENB	EQ3ENB	EQ2ENB	EQ1ENB	EQ0ENB	HPF2ENB	HPF1ENB	Filter Func Enable B	
		0	0	0	0	0	0	0	1		
0x70	0x71	Effect VOLB								Playback Effect Volume Control B	
		1	1	1	1	1	1	1	1		
0x72	0x73	PDATTB								Playback Digital Attenuator Control B	
		1	1	1	1	1	1	1	1		
0x74	0x75	EQGAIN0B								EQ gain Band0 B	
		1	1	1	0	0	1	1	1		
0x76	0x77	EQGAIN1B								EQ gain Band1 B	
		1	1	1	0	0	1	1	1		
0x78	0x79	EQGAIN2B								EQ gain Band2 B	
		1	1	1	0	0	1	1	1		
0x7a	0x7b	EQGAIN3B								EQ gain Band3 B	
		1	1	1	0	0	1	1	1		
0x7c	0x7d	EQGAIN4B								EQ gain Band4 B	
		1	1	1	0	0	1	1	1		
0x7e	0x7f	EQ0A0LB								EQ Band0 Coef0L B	
		0	0	0	0	0	0	0	0		
0x80	0x81	EQ0A0HB								EQ Band0 Coef0H B	
		0	0	0	0	0	0	0	0		
0x82	0x83	EQ0A1LB								EQ Band0 Coef1L B	
		0	0	0	0	0	0	0	0		
0x84	0x85	EQ0A1HB								EQ Band0 Coef1H B	
		0	0	0	0	0	0	0	0		
0x86	0x87	EQ1A0LB								EQ Band1 Coef0L B	
		0	0	0	0	0	0	0	0		
0x88	0x89	EQ1A0HB								EQ Band1 Coef0H B	
		0	0	0	0	0	0	0	0		
0x8a	0x8b	EQ1A1LB								EQ Band1 Coef1L B	
		0	0	0	0	0	0	0	0		
0x8c	0x8d	EQ1A1HB								EQ Band1 Coef1H B	
		0	0	0	0	0	0	0	0		
0x8e	0x8f	EQ2A0LB								EQ Band2 Coef0L B	
		0	0	0	0	0	0	0	0		
0x90	0x91	EQ2A0HB								EQ Band2 Coef0H B	
		0	0	0	0	0	0	0	0		
0x92	0x93	EQ2A1LB								EQ Band2 Coef1L B	
		0	0	0	0	0	0	0	0		
0x94	0x95	EQ2A1HB								EQ Band2 Coef1H B	
		0	0	0	0	0	0	0	0		
0x96	0x97	EQ3A0LB								EQ Band3 Coef0L B	
		0	0	0	0	0	0	0	0		

INDEX		b07	b06	b05	b04	b03	b02	b01	b00	Register Name	Note
R	W	(Initial)									
0x98	0x99	EQ3A0HB								EQ Band3	
		0	0	0	0	0	0	0	0	0	Coef0H B
0x9a	0x9b	EQ3A1LB								EQ Band3	
		0	0	0	0	0	0	0	0	0	Coef1L B
0x9c	0x9d	EQ3A1HB								EQ Band3	
		0	0	0	0	0	0	0	0	0	Coef1H B
0x9e	0x9f	EQ4A0LB								EQ Band4	
		0	0	0	0	0	0	0	0	0	Coef0L B
0xa0	0xa1	EQ4A0HB								EQ Band4	
		0	0	0	0	0	0	0	0	0	Coef0H B
0xa2	0xa3	EQ4A1LB								EQ Band4	
		0	0	0	0	0	0	0	0	0	Coef1L B
0xa4	0xa5	EQ4A1HB								EQ Band4	
		0	0	0	0	0	0	0	0	0	Coef1H B

## Register details explanation

Note: “-” indicates a reserved bit. They return “0” for read. Write “0” to the bit every time. If “1” is written to this bit, the operations cannot be guaranteed.

Don't write data to empty INDEX or register bit to guarantee normal operation.

A function with (\*)bit doesn't need internal clock to change state.

## Sampling Rate Setting Register

MAPCON	INDEX		b07 (Initial)	b06	b05	b04	b03	b02	b01	b00
	R	W								
0x0	0x00	0x01	-	-	-	-	SR			
			-	-	-	-	0	0	0	0

This register sets the sampling rate of the recording/playback. Please perform the change of this register level in (RECPLAY=0x0) at a recording/playback stop.

## SR [3:0]

Setting	Explanation
0x0	8kHz
0x1	11.025 kHz
0x2	12kHz
0x3	16kHz
0x4	22.05 kHz
0x5	24kHz
0x6	32kHz
0x7	44.1 kHz
0x8	48kHz

## Clock Enable Register

MAPCON	INDEX		b07 (Initial)	b06	b05	b04	b03	b02	b01	b00
	R	W								
0x0	0x0c	0x0d	TCLKEN	-	-	-	-	PLLOE	PLLEN	MCLKEN
			0	-	-	-	-	0	0	0

This register is a register to control the operation of the clock.

## MCLKEN

This bit sets permission / stop of the input of the MCLKI terminal. The input logic of the MCLKI terminal becomes invalid at the time of the stop and clock is not transmitted to the LSI inside.

Setting	Explanation
0	MCLKI terminal input stop A clock stops at the input first grade of the terminal
1	MCLKI terminal input permission

## PLLEN

This bit sets movement / stop of PLL.

Setting	Explanation
0	PLL stop
1	PLL movement

After setting the PLL Setting register, please set PLLEN bit to "1".

## PLLOE

This bit is to set the status of PLL output. Set this bit to “1” after PLL operation has stabilized. Also, this bit must be set to “1” if PLL is not used, otherwise internal clock cannot be provided.

Setting	Explanation
0	The PLL output is put under ban
1	PLL output permission

## TCLKEN

This bit sets the clock for the touch panel interface circuit.

TCLKEN	Explanation
0	Disable clock for the touch panel interface.
1	Enable clock for the touch panel interface.

Clock Input / Output Control Register

MAPCON	INDEX		b07 (Initial)	b06	b05	b04	b03	b02	b01	b00
	R	W								
0x0	0x0e	0x0f	-	-	-	PLLISEL		CLKSEL		
			-	-	-	0	0	0	0	0

This register is to select internal clock. It is to use or not use and to create MCLKI input or internal clock divided PLL.

CLKSEL[2:0]

Choose a clock to be use

Setting	Explanation
0x0	Using PLL lets you output 256fs clock from PLL. The PLL output is just used inside this LSI.
0x2	Using PLL lets you output 512fs clock from PLL. The clock that is divided by 1/2 the PLL output is used inside this LSI.
0x3	Using PLL lets you output 1024fs clock from PLL. The clock that is divided by 1/4 the PLL output is used inside this LSI.
0x4	Input 256fs clock to MCLKI terminal and PLL is not used. MCLKI terminal input is just used in this LSI.
0x6	Input 512fs clock to MCLKI terminal and PLL is not used. The clock that is divided by 1/2 the MCLKI terminal input is used inside this LSI.
0x7	Input 1024fs clock than MCLKI terminal and use it without using PLL. The clock that is divided by 1/4 the MCLKI terminal input is used inside this LSI.

PLLISEL[1:0]

When this bit chooses to input clock into PLL and does not use PLL, please set register to 0x0.

Setting	Explanation
0x0	Prohibited from setting
0x1	Use MCLKI terminal input
0x2	Use BCLK terminal input

Software Reset Register

MAPCON	INDEX		b07 (Initial)	b06	b05	b04	b03	b02	b01	b00
	R	W								
0x0	0x10	0x11	-	-	-	-	-	-	-	SOFTRST
			-	-	-	-	-	-	-	0

This register is for software reset. CPU interface and this register are reset by writing SOFTRST bit to "1". And then, write "0" for releasing reset.

Record/Playback Running Control Register

MAPCON	INDEX		b07 (Initial)	b06	b05	b04	b03	b02	b01	b00
	R	W								
0x0	0x12	0x13	-	-	-	-	-	RECPLAY		
			-	-	-	-	-	0	0	0

This register controls start / stop of the recording/playback operation of the LSI.

REPLAY [2:0]

This bit controls start / stop of the recording/playback operation of the LSI and it is feasible by recording and reproduction at the same time and monitor recording data from the reproduction course, and please refer to "state transition item about the recording reproduction control" for the transition between recording/playback states again. Transition between other states is prohibited. Please move to the next movement once by all means after having let recording/playback movement make a stop (REPLAY=0x0).

TCLKEN	Explanation
0x0	Sound Stop STATE Stop recording and playback.
0x1	Rec STATE Recording start. Microphone input is converted from analog to digital, and transferred through SAI.
0x2	Play STATE Playback start. SAI received data is converted from digital to analog and output from playback path.
0x3	Rec and Play STATE. Simultaneously Recording and Playback start. Microphone input is converted from analog to digital, and transferred through SAI and SAI received data is converted from digital to analog and output from playback path.
0x7	Monitor STATE. Monitoring the recording sound start. Microphone input is converted from analog to digital, and transferred through SAI and this data is converted from digital to analog and output from playback path.

MIC Input Charging Time Register

MAPCON	INDEX		b07 (Initial)	b06	b05	b04	b03	b02	b01	b00
	R	W								
0x0	0x14	0x15	-	-	MCTIME					
			-	-	0	0	0	0	0	0

This register is to select the wait time for microphone input load charge. The LSI work recording signal or playback signal are mute when from REPLAY is changed from 0x0 until MCTIME. This time contains required time of initializing DSP that is 40/fs. It must be waited the setting time to start recording or playback.

MCTIME is valid at playback. If it is necessary to start up earlier on playback, please set MCTIME to 0x00. It is minimum time.

MCTIME [5:0]

Setting	fs conversion	Time (fs=48kHz)
0x00	40/fs	0.8ms
0x01	128/fs	2.7ms
0x02	256/fs	5.3ms
0x03	384/fs	8.0ms
0x04 - 0x3D	(128/fs / step)	:
0x3E	7936/fs	165.3ms
0x3F	8064/fs	168.0ms

Note) the waiting time for microphone input load charge  
It is a recommended value of MIN1 coupling capacitor at the charge time.

Charge waiting time

Capacitor capacity	Charge waiting time (6 τ)
0.1μF	16ms
0.22μF	36ms

\* Charge time is proportional to capacity of capacitor.

Register MAP Control Register

MAPCON	INDEX		b07 (Initial)	b06	b05	b04	b03	b02	b01	b00
	R	W								
ALL	0x1c	0x1d	-	-	-	-	-	-	MAPCON	
			-	-	-	-	-	-	0	0

## MAPCON

This register controls register MAP.

Setting	Explanation
0x0	It is accessible to register MAP0
0x1	It is accessible to register MAP1
0x2	It is accessible to register MAP2
0x3	This is prohibited from setting

## Analog Reference Power Management Register

MAPCON	INDEX		b07 (Initial)	b06	b05	b04	b03	b02	b01	b00
	R	W								
0x0	0x20	0x21	HPREN	HPLEN	-	-	HPVDDEN	MICBEN	VMIDCON	
			0	0	-	-	0	0	0	0

This register controls headphones amplifier, LDO for the charge pump, the power-up / down of the hole Rch standard voltage generation circuit.

## VMIDCON [1:0]

These bits control power up and down of the VMID generation circuit. Power up time can be reduced by using high speed mode. VMID generation circuit should be changed to normal mode after high speed mode.

Setting	Explanation
0x0	power down
0x1	high speed mode power up
0x2	normal mode power up

## MICBEN

It controls Microphone bias circuit.

Setting	Explanation
0	Power down
1	Power up

## HPVDDEN

It controls HPAMP LDO for the charge pump.

Setting	Explanation
0	Disables
1	Enables

## HPLEN

It controls HPAMP. When using headphone, please set HPLEN/HPREN to "1".

Setting	Explanation
0	Disable(HPL)
1	Enable(HPL)

## HPREN

It controls HPAMP. When using headphones, please set HPLEN/HPREN "1".

Setting	Explanation
0	Disable(HPR)
1	Enable(HPR)

## Analog Input Power Management Register

MAPCON	INDEX		b07 (Initial)	b06	b05	b04	b03	b02	b01	b00
	R	W								
0x0	0x22	0x23	-	-	PGAATT	-	PGAEN	-	ADCEN	-
			-	-	0	-	0	-	0	-

This register controls the power-up / down of analog circuit.

## ADCEN

It controls power-up / down of the ADC.

Setting	Explanation
0	ADC power down
1	ADC power up

## PGAEN

It controls the power-up / down of the microphone amplifier.

Setting	Explanation
0	Microphone amplifier power down
1	Microphone amplifier power up

## PGAATT

It controls the gain of the microphone amplifier.

Setting	Explanation
0	Normal mode (0dB)
1	Attenuation mode (-9dB)

## DAC Power Management Register

MAPCON	INDEX		b07 (Initial)	b06	b05	b04	b03	b02	b01	b00
	R	W								
0x0	0x24	0x25	-	-	-	-	-	DACREN	DACLEN	-
			-	-	-	-	-	0	0	-

This register controls power-up / down of the DAC.

## DACLEN

It controls the power-up / down of the DAC left.

Setting	Explanation
0	power down
1	power up

## DACREN

It controls the power-up / down of the DAC right.

Setting	Explanation
0	power down
1	power up

## Speaker Amplifier Power Management Register

MAPCON	INDEX		b07 (Initial)	b06	b05	b04	b03	b02	b01	b00
	R	W								
0x0	0x26	0x27	SPMDSSEL	-	-	AVREN	COEFSEL	-	SPEN	AVLEN
			0	-	-	0	0	1	0	0

This register controls speaker amplifier volume's power-up / down.  
b02 is H fix.

## AVLEN

It controls power-up / down of the Lch analog volume.

AVLEN	Explanation
0x0	Lch analog volume power down
0x1	Lch analog volume power up

## SPEN

I control the power-up / down of the speaker amplifier.

SPEN	Explanation
0x0	Speaker amplifier power down
0x1	Speaker amplifier power up

## COEFSEL

In BU26154, an A side, a B side prepare filter setting at the time of the reproduction, a volume setting register. The register value of the A side, in the case of "1", I use a register level of the B side when this bit is "0".

COEFSEL	Explanation
0x0	It uses the register A side.
0x1	It uses the register B side.

## AVREN

It controls power-up / down of the Rch analog volume.

AVREN	Explanation
0x0	Rch analog volume power down
0x1	Rch analog volume power up

## SPMDSEL

It sets the speaker amplifier to D class or AB class. At the time of the change, set SPEN=0 before setting SPMDSEL.

SPMDSEL	Explanation
0x0	Set speaker amplifier to AB-class.
0x1	Set speaker amplifier to D-class.

## Thermal Shutdown Control Register

MAPCON	INDEX		b07 (initial)	b06	b05	b04	b03	b02	b01	b00
	R	W								
0x00	0x2c	0x2d	-	-	-	-	-	-	-	TSDEN
			-	-	-	-	-	-	-	1

## TSDEN

It controls a thermal shut down function.

Setting	Explanation
0x0	disable
0x1	enable

## Zero Cross Comparator Power Management Register

MAPCON	INDEX		b07 (Initial)	b06	b05	b04	b03	b02	b01	b00
	R	W								
0x0	0x2e	0x2f	-	-	-	-	-	-	ZCEN	-
			-	-	-	-	-	-	0	-

This register sets ON/OFF of the zero cross function of the digital volume.

## ZCEN

This function is effective for EFFECT VOLUME and RDATT

Setting	Explanation
0	disable
1	enable

## MICBIAS Voltage Control Register

MAPCON	INDEX		b07 (Initial)	b06	b05	b04	b03	b02	b01	b00
	R	W								
0x0	0x30	0x31	-	-	-	-	-	-	MICBCON	
			-	-	-	-	-	-	0	0

This register sets the output voltage reading of the microphone bias.

MICBCON [1:0]

These bits are to set the MICBIAS. Set the MICBIAS voltage less than HVDD x 0.85.

Setting	The output voltage
0x0	REGOUT / 2 x 1.67V
0x1	REGOUT / 2 x 2.22V
0x2	REGOUT / 2 x 2.78V
0x3	REGOUT / 2 x 3.33V

Analog Volume Control Register

MAPCON	INDEX		b07 (Initial)	b06	b05	b04	b03	b02	b01	b00
	R	W								
0x0	0x3a	0x3b	-	-	-	AVVOL				
			-	-	-	0	1	0	1	0

This register sets the Gain of the analog volume of Lch and Rch. The fader function of the AMP Volume Control Function Enable register is also available.

AVOL[5:0]

AVOL[5:0]	Gain[dB]	AVOL[5:0]	Gain[dB]
0x3Fto0x1a	-	0x09	-2.0
0x19	+18.0	0x08	-4.0
0x18	+17.0	0x07	-6.0
0x17	+16.0	0x06	-8.0
0x16	+15.0	0x05	-12.0
0x15	+14.0	0x04	-16.0
0x14	+13.0	0x03	-20.0
0x13	+12.0	0x02	-24.0
0x12	+11.0	0x01	-28.0
0x11	+10.0	0x00	MUTE
0x0f	+8.0		
0x0e	+7.0		
0x0d	+6.0		
0x0c	+4.0		
0x0b	+2.0		
0x0a	0.0		

Playback Digital Attenuator Control Register

MAPCON	INDEX		b07 (Initial)	b06	b05	b04	b03	b02	b01	b00
	R	W								
0x0	0x3e	0x3f	PDATT							
			1	1	1	1	1	1	1	1

Playback Digital Attenuator Control Register B

MAPCON	INDEX		b07 (Initial)	b06	b05	b04	b03	b02	b01	b00
	R	W								
0x2	0x72	0x73	PDATTB							
			1	1	1	1	1	1	1	1

PDATT[7:0]/ PDATTB[7:0]/

This register sets the Gain of the digital volume in the case of COEFSEL=0, the register level of PDATT is effective. In the case of COEFSEL=1, the register level of PDATTB is effective.

PDATT/ PDATTB	Gain (dB)	PDATT [7:0]	Gain (dB)	PDATT [7:0]	Gain (dB)	PDATT [7:0]	Gain (dB)
0x00 - to 0x6E	This is prohibited from setting	0x93	-54.0	0xB8	-35.5	0xDD	-17.0
0x6F	MUTE	0x94	-53.5	0xB9	-35.0	0xDE	-16.5
0x70	-71.5	0x95	-53.0	0xBA	-34.5	0xDF	-16.0
0x71	-71.0	0x96	-52.5	0xBB	-34.0	0xE0	-15.5
0x72	-70.5	0x97	-52.0	0xBC	-33.5	0xE1	-15.0
0x73	-70.0	0x98	-51.5	0xBD	-33.0	0xE2	-14.5
0x74	-69.5	0x99	-51.0	0xBE	-32.5	0xE3	-14.0
0x75	-69.0	0x9A	-50.5	0xBF	-32.0	0xE4	-13.5
0x76	-68.5	0x9B	-50.0	0xC0	-31.5	0xE5	-13.0
0x77	-68.0	0x9C	-49.5	0xC1	-31.0	0xE6	-12.5
0x78	-67.5	0x9D	-49.0	0xC2	-30.5	0xE7	-12.0
0x79	-67.0	0x9E	-48.5	0xC3	-30.0	0xE8	-11.5
0x7A	-66.5	0x9F	-48.0	0xC4	-29.5	0xE9	-11.0
0x7B	-66.0	0xA0	-47.5	0xC5	-29.0	0xEA	-10.5
0x7C	-65.5	0xA1	-47.0	0xC6	-28.5	0xEB	-10.0
0x7D	-65.0	0xA2	-46.5	0xC7	-28.0	0xEC	-9.5
0x7E	-64.5	0xA3	-46.0	0xC8	-27.5	0xED	-9.0
0x7F	-64.0	0xA4	-45.5	0xC9	-27.0	0xEE	-8.5
0x80	-63.5	0xA5	-45.0	0xCA	-26.5	0xEF	-8.0
0x81	-63.0	0xA6	-44.5	0xCB	-26.0	0xF0	-7.5
0x82	-62.5	0xA7	-44.0	0xCC	-25.5	0xF1	-7.0
0x83	-62.0	0xA8	-43.5	0xCD	-25.0	0xF2	-6.5
0x84	-61.5	0xA9	-43.0	0xCE	-24.5	0xF3	-6.0
0x85	-61.0	0xAA	-42.5	0xCF	-24.0	0xF4	-5.5
0x86	-60.5	0xAB	-42.0	0xD0	-23.5	0xF5	-5.0
0x87	-60.0	0xAC	-41.5	0xD1	-23.0	0xF6	-4.5
0x88	-59.5	0xAD	-41.0	0xD2	-22.5	0xF7	-4.0
0x89	-59.0	0xAE	-40.5	0xD3	-22.0	0xF8	-3.5
0x8A	-58.5	0xAF	-40.0	0xD4	-21.5	0xF9	-3.0
0x8B	-58.0	0xB0	-39.5	0xD5	-21.0	0xFA	-2.5
0x8C	-57.5	0xB1	-39.0	0xD6	-20.5	0xFB	-2.0
0x8D	-57.0	0xB2	-38.5	0xD7	-20.0	0xFC	-1.5
0x8E	-56.5	0xB3	-38.0	0xD8	-19.5	0xFD	-1.0
0x8F	-56.0	0xB4	-37.5	0xD9	-19.0	0xFE	-0.5
0x90	-55.5	0xB5	-37.0	0xDA	-18.5	0xFF	0.0 (Prohibit setting)
0x91	-55.0	0xB6	-36.5	0xDB	-18.0		
0x92	-54.5	0xB7	-36.0	0xDC	-17.5		

## Play HPF2 Setting Register

MAPCON	INDEX		b07 (Initial)	b06	b05	b04	b03	b02	b01	b00
	R	W								
0x0	0x46	0x47	-	-	HPF2CSEL	PLHPF2CUT			PLHPF2OD	PLHPF2EN
			-	-	0	0	0	0	0	0

## Play HPF2 Setting Register B

This register is a setting register of HPF for the reproduction. In the case of COEFSEL=0, PLHPF2EN, PLHPF2OD, PLHPF2CUT, the register level of HPF2CEL are effective. In the case of COEFSEL=1, PLHPF2ENB, PLHPF2ODB, PLHPF2CUTB, the value of the HPF2CELB register become effective.

## PLHPF2EN/ PLHPF2ENB

This bit is enables HPF for the reproduction.

PLHPF2EN/ PLHPF2ENB	Explanation
0	Disable
1	Enable

## PLHPF2OD/ PLHPF2ODB

This bit sets the degree of HPF for the reproduction.

PLHPF2OD/ PLHPF2ODB	Explanation
0	The second order
1	The first order

## PLHPF2CUT/ PLHPF2CUTB

This bit sets the cut-off frequency of HPF for reproduction. In the case of "0", HPF2CEL becomes effective for setting this bit.

PLHPF2CUT/ PLHPF2CUTB	F <sub>s</sub> =8,16,32kHz
0x00	80Hz
0x01	100Hz
0x02	130Hz
0x03	160Hz
0x04	200Hz
0x05	260Hz
0x06	320Hz
0x07	400Hz

## HPF2CEL/ HPF2CELB

I make HPF at the time of the reproduction programmable, or I make it parametric, or this bit sets it.

HPF2CEL/ HPF2CELB	Explanation
0	PLHPF2CUT is effective.
1	PHPF2COEFL/H is effective.

## Amplifier Volume Control Function Enable Register

MAPCON	INDEX		b07 (Initial)	b06	b05	b04	b03	b02	b01	b00
	R	W								
0x0	0x48	0x49	-	-	-	-	-	-	AVMUTE	AVFADE
			-	-	-	-	-	-	0	0

This register controls the fading function of the analog volume.

## AVFADE

It sets the fading function of the analog volume to ON/OFF.

AVFADE	Explanation
0	Fading function OFF When a register set point of AVOL is just used for a real Volume price and wants to do it and changes a value, setting of the analog volume is updated immediately.
1	Fading function ON When a register set point of AVOL was updated, a gain of the analog volume changes by a +/-1 step towards a register set point after the update in step time for AVFCON register setting.

## AVMUTE

When this is set, mute becomes effective for the analog volume at the time of reproduction. It can control fading for the mute shift by this bit by the analog volume forcibly by AVFADE.

AVMUTE	Explanation
0	As for the analog volume, a register set point of AVOL is effective.
1	At the time of re-start: The analog volume is set to MUTE. It comes back to the setting Volume in AVOL by canceling it because it writes it. This register level of AVOL cannot be replaced by the setting of this bit.

Amplifier Volume Fader Control Register

MAPCON	INDEX		b07 (Initial)	b06	b05	b04	b03	b02	b01	b00
	R	W								
0x0	0x4a	0x4b	-	-	-	-	-	AVFCON		
			-	-	-	-	-	0	0	0

This register controls the amplifier volume fade function.

AVFCON[2:0]

These bits are to set the volume change step time of the amplifier volume fade function. The volume changes step by step with this setting period. Step time is in proportion to sampling frequency (fs) as following table.

AVFCON[2:0]	fs conversion	time(fs=48kHz)
0x0	1/fs	20.8µs
0x1	4/fs	83.3µs
0x2	16/fs	333µs
0x3	64/fs	1.33ms
0x4	256/fs	5.33ms
0x5	1024/fs	21.3ms
0x6	4096/fs	85.3ms
0x7	16384/fs	341.ms

Play Programmable HPF2 CoefL Register

Play Programmable HPF2 CoefH Register

MAPCON	INDEX		b07 (Initial)	b06	b05	b04	b03	b02	b01	b00
	R	W								
0x0	0x4c	0x4d	PHPF2C0L							
			0	0	0	0	0	0	0	0
0x0	0x4e	0x4f	PHPF2C0H							
			0	0	0	0	0	0	0	0

Play Programmable HPF2 CoefL Register B

Play Programmable HPF2 CoefH Register B

MAPCON	INDEX		b07 (Initial)	b06	b05	b04	b03	b02	b01	b00
	R	W								
0x2	0x4c	0x4d	PHPF2C0LB							
			0	0	0	0	0	0	0	0
0x2	0x4e	0x4f	PHPF2C0HB							
			0	0	0	0	0	0	0	0

It is the register settings of the programmable high path filter cut-off frequency for the reproduction.

HPF2CSEL bit becomes effective when the register value is equal to "1".

If COEFSEL=0, then the register level of PHPF2C0L, PHPF2C0H is effective.

If COEFSEL=1, then the register level of PHPF2C0LB, PHPF2C0HB is effective.

PHPF2C0L [7:0]/ PHPF2C0LB [7:0]

PHPF2C0H [7:0]/ PHPF2C0HB [7:0]

This sets the cut-off frequency of the programmable high path filter for the reproduction.

Please refer for the setting method.

DAC Clock Setting Register

MAPCON	INDEX		b07 (Initial)	b06	b05	b04	b03	b02	b01	b00
	R	W								
0x0	0x58	0x59	-	-	OSRSEL		-	-	-	-
			-	-	0	0	-	-	-	-

This register sets the DAC clock movement to be used in this LSI.

OSRSEL [1:0]

This register decides sampling frequency.

Setting	Explanation
0x0	8k, 11.025k, 12kHz
0x1	16k, 22.05k, 24kHz
0x2	32k, 44.1k, 48kHz
0x3	This is prohibited from setting

Mic Interface Control Register

MAPCON	INDEX		b07 (Initial)	b06	b05	b04	b03	b02	b01	b00
	R	W								
0x0	0x5a	0x5b	MINVOL			-	-	-	MINDIF	-
			1	0	0	-	-	-	0	-

This register controls the microphone input interface.

MINDIF

It sets the MIC movement mode.

Setting	Explanation
0	Single-end mode
1	Differential mode

MINVOL

This bit sets the Analog MIC volume.

MINVOL	Gain
0x00	6dB
0x01	9dB
0x02	12dB
0x03	15dB
0x04	18dB
0x05	21dB
0x06	24dB
0x07	27dB

Sound Effect Mode Register

MAPCON	INDEX		b07 (Initial)	b06	b05	b04	b03	b02	b01	b00
	R	W								
0x0	0x5c	0x5d	SEMODE[7]	-	-	-	-	SEMODE[2:0]		
			0	-	-	-	-	0	0	0

Sound Effect Mode Register B

MAPCON	INDEX		b07 (Initial)	b06	b05	b04	b03	b02	b01	b00
	R	W								
0x2	0x5c	0x5d	SEMODEB[7]	-	-	-	-	SEMODEB[2:0]		
			0	-	-	-	-	0	0	0

If COEFSEL=0, then the register level of SEMODE is effective. If COEFSEL=1, then the value of the SEMODEB register becomes effective.

## SEMODE [7]/SEMODEB [7]

You choose a course putting Filter Block, and please refer to the clause of "the signal flow" of "the function explanation" for Filter Block.

SEMODE[7]/ SEMODEB [7]	Explanation
0	Use Filter Block on Recording path.
1	Use Filter Block on Playback path.

## SEMODE [2:0]/ SEMODEB [2:0]

This sets distribution of EQ/Notch Filter.

SEMODE[2:0]/ SEMODEB[2:0]	Explanation
0x0	Notch5 band / EQ0 band
0x1	Notch4 band / EQ1 band
0x2	Notch3 band / EQ2 band
0x3	Notch2 band / EQ3 band
0x4	Notch1 band / EQ4 band
0x5	Notch0 band / EQ5 band

When "0x01" is set, Band0 to Band3 filters Notch, and Band4 becomes the EQ.

## SAI Transmitter Control Register

MAPCON	INDEX		b07 (Initial)	b06	b05	b04	b03	b02	b01	b00
	R	W								
0x0	0x60	0x61	PCMFO24	FMTO	MSBO	ISSCKO	AFOO	DLYO	WSLO	
			1	1	0	0	0	0	0	0

This register controls the SAI transmission format setting. The RECPLOY bit of the Record/Playback Running Control register, please change this register in recording stop state (0x0), and please use it by setting again same as the SAI reception side (SAI Receiver Control register).

## WSLO

You appoint LRCLK polarity at the time of the transmission of this LSI, and please set this bit in "1" in (FMTO at the time of "1") in a transfer mode by all means in the frame same period.

Setting	Explanation
0	Left channel transmission at SAI_LRCLK is "L" level; right channel transmission at SAI_LRCLK is "H" level.
1	Left channel transmission at SAI_LRCLK is "H" level; right channel transmission at SAI_LRCLK is "L" level.

## DLYO

This bit appoints 1 clock delay existence / nothing of transmission data.

Setting	Explanation
0	Serial data delay existence
1	Serial data delay nothing

## AFOO

You appoint in front of filling / attacking the enemy from behind of transmission data, and, in the case of a slave mode, this bit is ignored, and it is in previous final stage is fixed, and please set this bit in "0" in (FMTO at the time of "1") in a transfer mode by all means in the frame same period.

Setting	Explanation
0	Left-justify
1	Right-justify

## ISSCKO

This bit sets BCLK terminal to 32fs/64fs.

Setting	Explanation
0	32fs
1	64fs

## MSBO

This bit sets the MSB first /LSB first data transmission.

Setting	Explanation
0	MSB first
1	LSB first

## FMTO

This bit sets the transmission mode.

Setting	Explanation
0	LRCLK transfer mode
1	Frame synchronization transfer mode

## PCMFO24

This bit sets PCM format of the SAI transmission.

Setting	Explanation
0x2	16bit PCM
0x3	24bit PCM
Other than the above	This is prohibited from setting

## SAI Receiver Control Register

MAPCON	INDEX		b07 (Initial)	b06	b05	b04	b03	b02	b01	b00
	R	W								
0x0	0x62	0x63	PCMF124	FMTI	MSBI	ISSCKI	AFOI	DLYI	WSLI	
			1	1	0	0	0	0	0	0

This register is a register controlling SAI reception format setting, and RECPLAY bit of the Record/Playback Running Control register, please change this register in recording stop state (0x0), and please use it by setting again same as the SAI transmission side (SAI Transmitter Control register).

## WSLI

This bit selects LRCLK polarity of the LSI. This bit must be set to "1" when at Flame synchronous transfer mode (FMTI is "1").

Setting	Explanation
0	Left channel is received when SAI_LRCLK is "L" level, right channel is received at SAI_LRCLK is "H" level.
1	Left channel is received when SAI_LRCLK is "H" level, right channel is received at SAI_LRCLK is "L" level.

## DLYI

This bit specifies the existence for serial input data one clock delay of master device.

Setting	Explanation
0	Serial data delay existence
1	Serial data delay nothing

## AFOI

This bit sets the receiving data to be Left-justify or Right-justify. This bit must be set to "0" when at Flame synchronous transfer mode (FMTI is "1").

Setting	Explanation
0	Left-justify
1	Right-justify

## ISSCKI

This bit sets the sampling frequency of SAI\_BCLK pin.

Setting	Explanation
0	32fs
1	64fs

## MSBI

This bit sets the SAI receiving data to be MSB-first or LSB-first.

Setting	Explanation
0	MSB first
1	LSB first

## FMTI

This bit sets the receiving mode

Setting	Explanation
0	LRCLK transfer mode
1	Frame synchronization transfer mode

## PCMF124

This bit sets the SAI PCM receiving format.

Setting	Explanation
0x2	16bit PCM
0x3	24bit PCM
Other than the above	This is prohibited from setting

## SAI Mode select Register

MAPCON	INDEX		b07 (Initial)	b06	b05	b04	b03	b02	b01	b00
	R	W								
0x0	0x64	0x65	-	-	-	BSWP	-	-	-	MST
			-	-	-	0	-	-	-	0

This register is a register setting a movement mode of SAI, and RECPLAY bit of the Record/Playback Running Control register, please change this register in recording stop state (0x0).

## MST

It appoints whether this bit uses SAI with a master mode or a slave mode.

Setting	Explanation
0	Slave mode
1	Master mode

## BSWP

As for this bit, it is done byte swap I2S data with PCM format by 16bitPCM without depending on the setting of the I2S Receiver Control/I2S Transmitter Control register at the time of setting when I set byte swap having I2S or not on the same side of transmission and reception data and there is byte swap and sets it.

Setting	Explanation
0	There is no byte swap (16bit data line up :15bit-8bit,7bit-0bit) (24bit data line up :23bit-16bit,15bit-8bit,7bit-0bit)
1	There is byte swap (16bit data line up :7bit-0bit,15bit-8bit) (24bit data line up :7bit-0bit,15bit-8bit 23bit-16bit)

## DSP Filter Function Enable Register

MAPCON	INDEX		b07 (Initial)	b06	b05	b04	b03	b02	b01	b00
	R	W								
0x0	0x66	0x67	HPF2OD	EQ4EN	EQ3EN	EQ2EN	EQ1EN	EQ0EN	HPF2EN	HPF1EN
			0	0	0	0	0	0	0	0

## DSP Filter Function Enable Register

MAPCON	INDEX		b07 (Initial)	b06	b05	b04	b03	b02	b01	b00
	R	W								
0x0	0x66	0x67	HPF2OD	EQ4EN	EQ3EN	EQ2EN	EQ1EN	EQ0EN	HPF2EN	HPF1EN
			0	0	0	0	0	0	0	0

## DSP Filter Function Enable Register B

MAPCON	INDEX		b07 (Initial)	b06	b05	b04	b03	b02	b01	b00
	R	W								
0x2	0x66	0x67	HPF2ODB	EQ4ENB	EQ3ENB	EQ2ENB	EQ1ENB	EQ0ENB	HPF2ENB	HPF1ENB
			0	0	0	0	0	0	0	0

This register sets the filter function of the digital code processing ON/OFF.

If COEFSEL=0, then register level of HPF1/2EN, EQ0/1/2/3/4EN, HPF2OD is effective. If COEFSEL=1, then value of HPF1/2ENB, EQ0/1/2/3/4ENB, HPF2ODB register becomes effective.

## HPF1EN/ HPF1ENB

This bit is to set ON or OFF of a first-order high pass filter for DC cut. Do not change this bit during operation of the recording (0x13/0x14: RECPLAY=0x1, 0x3, or 0x7). If this bit is changed, the noise may be generated.

When this IC being operated the playing (RECPLAY=0x2), this bit operating don't have effective.

HPF1EN/ HPF1ENB	Explanation
0	Primary high-pass filter OFF for the DC cut
1	Primary high-pass filter ON for the DC cut

## HPF2EN/ HPF2ENB

This bit is to set ON or OFF of a second-order high pass filter for noise cut. Do not change this bit during operation of the recording (RECPLAY=0x1,0x3, or 0x7). If this bit is changed, the noise may be generated.

The bit of HPF2EN is effective only when 0xA6/0xA7:RLPFEN is enable.

HPF2EN/ HPF2ENB	Explanation
0	Second high-pass filter OFF for noise reduction
1	Second high-pass filter ON for noise reduction

## EQ0EN/EQ0ENB

This bit is to set ON or OFF of equalizer band 0. In case of changing this bit during recording and playback operation (RECPLAY=0x1, 0x2, 0x3, or 0x7), enables digital volume fade function (0x68/0x69: DVFADE=1) and then change the gain to 0dB.

EQ0EN/ EQ0ENB	Explanation
0	Equalizer band 0 OFF
1	Equalizer band 0 ON

## EQ1EN/EQ1ENB

This bit is to set ON or OFF of equalizer band 1. In case of changing this bit during recording and playback operation (0x13/0x14: RECPLAY=0x1, 0x2, 0x3, or 0x7), enables digital volume fade function (0x68/0x69: DVFADE=1) and then change the gain to 0dB.

EQ1EN/ EQ1ENB	Explanation
0	Equalizer band 1 OFF
1	Equalizer band 1 ON

## EQ2EN/EQ2ENB

This bit is to set ON or OFF of equalizer band 2. In case of changing this bit during recording and playback operation (0x13/0x14: RECPLAY=0x1, 0x2, 0x3, or 0x7), enables digital volume fade function (0x68/0x69: DVFADE=1) and then change the gain to 0dB.

EQ2EN/ EQ2ENB	Explanation
0	Equalizer band 2 OFF
1	Equalizer band 2 ON

## EQ3EN/EQ3ENB

This bit is to set ON or OFF of equalizer band 3. In case of changing this bit during recording and playback operation (0x13/0x14: RECPLAY=0x1, 0x2, 0x3, or 0x7), enables digital volume fade function (0x68/0x69: DVFADE=1) and then change the gain to 0dB.

EQ3EN/ EQ3ENB	Explanation
0	Equalizer band 3 OFF
1	Equalizer band 3 ON

## EQ4EN/EQ4ENB

This bit is to set ON or OFF of equalizer band 4. In case of changing this bit during recording and playback operation (0x13/0x14: RECPLAY=0x1, 0x2, 0x3, or 0x7), enables digital volume fade function (0x68/0x69: DVFADE=1) and then change the gain to 0dB.

EQ4EN/ EQ4ENB	Explanation
0	Equalizer band 4 OFF
1	Equalizer band 4 ON

## HPF2OD/HPF0DB

This bit is to set number of high pass filter order (HPF2EN bit) for noise cut. In recording or playback operation(0x13/0x14: RECPLAY≠0) ,do not change this bit. If this bit is changed, the noise may be generated.

HPF2OD/ HPF20DB	Explanation
0	The second filter
1	Primary filter

## Digital Volume Control Function Enable Register

MAPCON	INDEX		b07 (Initial)	b06	b05	b04	b03	b02	b01	b00
	R	W								
0x0	0x68	0x69	-	-	-	DVMUTE	DVFADE	-	RALCEN	PALCEN
			-	-	-	0	0	-	0	0

This register sets ON/OFF of digital, the Volume control function.

## PALCEN

This bit is to set ON or OFF of the playing ALC.

It must not be wrote during recording and playback operation (0x13/0x14: RECPLAY=0x1, 0x3, or 0x7).

If this bit was set as the operation, this IC cannot guarantee correct operating.

PALCEN	Explanation
0	Reproduction ALC OFF
1	Reproduction ALCON

## RALCEN

This bit is to set ON or OFF of the recording ALC.

It must not be wrote during recording and playback operation (0x13/0x14: RECPLAY=0x2).

If this bit was set as the operation, this IC cannot guarantee correct operating.

RALCEN	Explanation
0	Recording ALC OFF
1	Recording ALC ON

## DVFADE

This bit is to set ON or OFF of the digital volume fade function.

The fade function is effective for recording/playback digital volume and equalizer gain.

DVFADE	Explanation
0	Fading Function OFF: The register setting value of RDATT, PDATT and EQGAIN0 to 3 is used actual volume value as it is. Therefore the value is effective immediate.
1	Fading Function ON: The volume is changing to the register setting value of RDATT, PDATT and EQGAIN0 to 3 with 1 step per DVFCOEN register step time.

## DVMUTE

This bit is to set MUTE of the digital volume. This mute function is effective for the recording digital volume at recording and effective for playback digital volume at playback. The fade function by DVFADE is effective against the volume change by this bit.

DVMUTE	Explanation
0	Register value of RDVOL and PDATT is effective.
1	Digital volume is set to MUTE. Register value of RDVOL and PDATT cannot be changed by this bit, the volume is resumed by releasing this bit (DVMUTE=0) to the original setting value of RDVOL and PDVOL.

Mixer & Volume Control Register

MAPCON	INDEX		b07 (Initial)	b06	b05	b04	b03	b02	b01	b00
	R	W								
0x0	0x6a	0x6b	DVFCON				RMCON		LMCON	
			0	0	0	0	0	0	0	0

This register controls L/R mixer processing at the time of the SAI reception and a fading function of the digital Volume.

LMCON[1:0]

This bit sets the input channel of SAI reception data of the DAC (Lch).

Setting	Explanation
0x0	I use L
0x1	I use R
0x2	I use (L+R)
0x3	I use (L+R)/2

RMCON[1:0]

This bit sets it about SAI reception data which channel you input into DAC (Rch).

Setting	Explanation
0x0	I use R
0x1	I use L
0x2	I use (L+R)
0x3	I use (L+R)/2

DVFCON[3:0]

These bits are to set the volume change step time of the digital volume fade function. The volume changes step by step (0.5dB) with this setting period. Step time is in proportion to sampling frequency (fs) as following table.

Setting	fs conversion	Time(fs=48kHz)
0x0	1/fs	20.8µs
0x1	2/fs	41.7µs
0x2	4/fs	83.3µs
0x3	8/fs	167µs
0x4	16/fs	333µs
0x5	32/fs	667µs
0x6	64/fs	1.33ms
0x7	128/fs	2.67ms
0x8	256/fs	5.33ms
0x9	512/fs	10.7ms
0xA	1024/fs	21.3ms
0xB	2048/fs	42.7ms
0xC	4096/fs	85.3ms
0xD	8192/fs	171ms
0xE	16384/fs	341ms

Record Digital Attenuator Control Register

MAPCON	INDEX		b07 (Initial)	b06	b05	b04	b03	b02	b01	b00
	R	W								
0x0	0x6c	0x6d	RDVOL							
			1	1	1	1	1	1	1	1

This register sets digital Volume Gain of the recording course.  
MUTE could be set from -71.5dB to 0.0dB by 0.5dB step.

RDATT[7:0]

Setting	Gain(dB)	Setting	Gain(dB)	Setting	Gain(dB)	Setting	Gain(dB)
0x00 - 0x6E	This is prohibited from setting	0x93	-54.0	0xB8	-35.5	0xDD	-17.0
0x6F	MUTE	0x94	-53.5	0xB9	-35.0	0xDE	-16.5
0x70	-71.5	0x95	-53.0	0xBA	-34.5	0xDF	-16.0
0x71	-71.0	0x96	-52.5	0xBB	-34.0	0xE0	-15.5
0x72	-70.5	0x97	-52.0	0xBC	-33.5	0xE1	-15.0
0x73	-70.0	0x98	-51.5	0xBD	-33.0	0xE2	-14.5
0x74	-69.5	0x99	-51.0	0xBE	-32.5	0xE3	-14.0
0x75	-69.0	0x9A	-50.5	0xBF	-32.0	0xE4	-13.5
0x76	-68.5	0x9B	-50.0	0xC0	-31.5	0xE5	-13.0
0x77	-68.0	0x9C	-49.5	0xC1	-31.0	0xE6	-12.5
0x78	-67.5	0x9D	-49.0	0xC2	-30.5	0xE7	-12.0
0x79	-67.0	0x9E	-48.5	0xC3	-30.0	0xE8	-11.5
0x7A	-66.5	0x9F	-48.0	0xC4	-29.5	0xE9	-11.0
0x7B	-66.0	0xA0	-47.5	0xC5	-29.0	0xEA	-10.5
0x7C	-65.5	0xA1	-47.0	0xC6	-28.5	0xEB	-10.0
0x7D	-65.0	0xA2	-46.5	0xC7	-28.0	0xEC	-9.5
0x7E	-64.5	0xA3	-46.0	0xC8	-27.5	0xED	-9.0
0x7F	-64.0	0xA4	-45.5	0xC9	-27.0	0xEE	-8.5
0x80	-63.5	0xA5	-45.0	0xCA	-26.5	0xEF	-8.0
0x81	-63.0	0xA6	-44.5	0xCB	-26.0	0xF0	-7.5
0x82	-62.5	0xA7	-44.0	0xCC	-25.5	0xF1	-7.0
0x83	-62.0	0xA8	-43.5	0xCD	-25.0	0xF2	-6.5
0x84	-61.5	0xA9	-43.0	0xCE	-24.5	0xF3	-6.0
0x85	-61.0	0xAA	-42.5	0xCF	-24.0	0xF4	-5.5
0x86	-60.5	0xAB	-42.0	0xD0	-23.5	0xF5	-5.0
0x87	-60.0	0xAC	-41.5	0xD1	-23.0	0xF6	-4.5
0x88	-59.5	0xAD	-41.0	0xD2	-22.5	0xF7	-4.0
0x89	-59.0	0xAE	-40.5	0xD3	-22.0	0xF8	-3.5
0x8A	-58.5	0xAF	-40.0	0xD4	-21.5	0xF9	-3.0
0x8B	-58.0	0xB0	-39.5	0xD5	-21.0	0xFA	-2.5
0x8C	-57.5	0xB1	-39.0	0xD6	-20.5	0xFB	-2.0
0x8D	-57.0	0xB2	-38.5	0xD7	-20.0	0xFC	-1.5
0x8E	-56.5	0xB3	-38.0	0xD8	-19.5	0xFD	-1.0
0x8F	-56.0	0xB4	-37.5	0xD9	-19.0	0xFE	-0.5
0x90	-55.5	0xB5	-37.0	0xDA	-18.5	0xFF	0.0
0x91	-55.0	0xB6	-36.5	0xDB	-18.0		
0x92	-54.5	0xB7	-36.0	0xDC	-17.5		

Playback Effect Volume Control Register

MAPCON	INDEX		b07 (Initial)	b06	b05	b04	b03	b02	b01	b00
	R	W								
0x0	0x70	0x71	Effect VOL							
			1	1	1	1	1	1	1	1

Playback Effect Volume Control Register B

MAPCON	INDEX		b07 (Initial)	b06	b05	b04	b03	b02	b01	b00
	R	W								
0x2	0x70	0x71	Effect VOLB							
			1	1	1	1	1	1	1	1

This register sets the digital Volume Gain of the reproduction course. If COEFSEL=0, then register level of Effect Vol is effective. If COEFSEL=1, then value of the Effect Vol B register becomes effective. MUTE could be set from -71.5dB to 0.0dB by 0.5dB step.

Effect Vol[7:0]/ Effect Vol B[7:0]

Sets the Digital Volume Gain.

Effect Vol/ Effect Vol B	Gain(dB)	Setting	Gain(dB)	Setting	Gain(dB)	Setting	Gain(dB)
0x00 - 0x6E	This is prohibited from setting	0x93	-54.0	0xB8	-35.5	0xDD	-17.0
0x6F	MUTE	0x94	-53.5	0xB9	-35.0	0xDE	-16.5
0x70	-71.5	0x95	-53.0	0xBA	-34.5	0xDF	-16.0
0x71	-71.0	0x96	-52.5	0xBB	-34.0	0xE0	-15.5
0x72	-70.5	0x97	-52.0	0xBC	-33.5	0xE1	-15.0
0x73	-70.0	0x98	-51.5	0xBD	-33.0	0xE2	-14.5
0x74	-69.5	0x99	-51.0	0xBE	-32.5	0xE3	-14.0
0x75	-69.0	0x9A	-50.5	0xBF	-32.0	0xE4	-13.5
0x76	-68.5	0x9B	-50.0	0xC0	-31.5	0xE5	-13.0
0x77	-68.0	0x9C	-49.5	0xC1	-31.0	0xE6	-12.5
0x78	-67.5	0x9D	-49.0	0xC2	-30.5	0xE7	-12.0
0x79	-67.0	0x9E	-48.5	0xC3	-30.0	0xE8	-11.5
0x7A	-66.5	0x9F	-48.0	0xC4	-29.5	0xE9	-11.0
0x7B	-66.0	0xA0	-47.5	0xC5	-29.0	0xEA	-10.5
0x7C	-65.5	0xA1	-47.0	0xC6	-28.5	0xEB	-10.0
0x7D	-65.0	0xA2	-46.5	0xC7	-28.0	0xEC	-9.5
0x7E	-64.5	0xA3	-46.0	0xC8	-27.5	0xED	-9.0
0x7F	-64.0	0xA4	-45.5	0xC9	-27.0	0xEE	-8.5
0x80	-63.5	0xA5	-45.0	0xCA	-26.5	0xEF	-8.0
0x81	-63.0	0xA6	-44.5	0xCB	-26.0	0xF0	-7.5
0x82	-62.5	0xA7	-44.0	0xCC	-25.5	0xF1	-7.0
0x83	-62.0	0xA8	-43.5	0xCD	-25.0	0xF2	-6.5
0x84	-61.5	0xA9	-43.0	0xCE	-24.5	0xF3	-6.0
0x85	-61.0	0xAA	-42.5	0xCF	-24.0	0xF4	-5.5
0x86	-60.5	0xAB	-42.0	0xD0	-23.5	0xF5	-5.0
0x87	-60.0	0xAC	-41.5	0xD1	-23.0	0xF6	-4.5
0x88	-59.5	0xAD	-41.0	0xD2	-22.5	0xF7	-4.0
0x89	-59.0	0xAE	-40.5	0xD3	-22.0	0xF8	-3.5
0x8A	-58.5	0xAF	-40.0	0xD4	-21.5	0xF9	-3.0
0x8B	-58.0	0xB0	-39.5	0xD5	-21.0	0xFA	-2.5
0x8C	-57.5	0xB1	-39.0	0xD6	-20.5	0xFB	-2.0
0x8D	-57.0	0xB2	-38.5	0xD7	-20.0	0xFC	-1.5
0x8E	-56.5	0xB3	-38.0	0xD8	-19.5	0xFD	-1.0
0x8F	-56.0	0xB4	-37.5	0xD9	-19.0	0xFE	-0.5
0x90	-55.5	0xB5	-37.0	0xDA	-18.5	0xFF	0.0
0x91	-55.0	0xB6	-36.5	0xDB	-18.0		
0x92	-54.5	0xB7	-36.0	0xDC	-17.5		

EQ Band0 Gain Setting Register  
 EQ Band1 Gain Setting Register  
 EQ Band2 Gain Setting Register  
 EQ Band3 Gain Setting Register  
 EQ Band4 Gain Setting Register

MAPCON	INDEX		b07 (Initial)	b06	b05	b04	b03	b02	b01	b00
	R	W								
0x0	0x74	0x75	EQGAIN0							
			1	1	1	0	0	1	1	1
0x0	0x76	0x77	EQGAIN1							
			1	1	1	0	0	1	1	1
0x0	0x78	0x79	EQGAIN2							
			1	1	1	0	0	1	1	1
0x0	0x7a	0x7b	EQGAIN3							
			1	1	1	0	0	1	1	1
0x0	0x7c	0x7d	EQGAIN4							
			1	1	1	0	0	1	1	1

EQ Band0 Gain Setting Register B  
 EQ Band1 Gain Setting Register B  
 EQ Band2 Gain Setting Register B  
 EQ Band3 Gain Setting Register B  
 EQ Band4 Gain Setting Register B

MAPCON	INDEX		b07 (Initial)	b06	b05	b04	b03	b02	b01	b00
	R	W								
0x2	0x74	0x75	EQGAIN0B							
			1	1	1	0	0	1	1	1
0x2	0x76	0x77	EQGAIN1B							
			1	1	1	0	0	1	1	1
0x2	0x78	0x79	EQGAIN2B							
			1	1	1	0	0	1	1	1
0x2	0x7a	0x7b	EQGAIN3B							
			1	1	1	0	0	1	1	1
0x2	0x7c	0x7d	EQGAIN4B							
			1	1	1	0	0	1	1	1

This register sets the gain of each band of the equalizer. If COEFSEL=0, then the register level of EQGAIN0 to 4 is effective. If COEFSEL=1, then value of the EQGAIN0B to EQGAIN4B register becomes effective.

This register can set EQ gain from -71.5dB to 12.0dB(step by step 0.5dB). Also it can set MUTE.  
 EQ can work as a notch filter by MUTE setting.

EQGAIN/ EQGAINB 0 - to 4 [7:0]	Gain (0dB)	EQGAIN/ EQGAINB 0 - to4[7:0]	Gain (0dB)	EQGAIN/ EQGAINB 0 - to4[7:0]	Gain (dB)	EQGAIN/ EQGAINB 0 - to4[7:0]	Gain (dB)
0x00 - to 0x57	MUTE	0x82	-50.5	0xAD	-29.0	0xD8	-7.5
0x58	-71.5	0x83	-50.0	0xAE	-28.5	0xD9	-7.0
0x59	-71.0	0x84	-49.5	0xAF	-28.0	0xDA	-6.5
0x5A	-70.5	0x85	-49.0	0xB0	-27.5	0xDB	-6.0
0x5B	-70.0	0x86	-48.5	0xB1	-27.0	0xDC	-5.5
0x5C	-69.5	0x87	-48.0	0xB2	-26.5	0xDD	-5.0
0x5D	-69.0	0x88	-47.5	0xB3	-26.0	0xDE	-4.5
0x5E	-68.5	0x89	-47.0	0xB4	-25.5	0xDF	-4.0
0x5F	-68.0	0x8A	-46.5	0xB5	-25.0	0xE0	-3.5
0x60	-67.5	0x8B	-46.0	0xB6	-24.5	0xE1	-3.0
0x61	-67.0	0x8C	-45.5	0xB7	-24.0	0xE2	-2.5
0x62	-66.5	0x8D	-45.0	0xB8	-23.5	0xE3	-2.0
0x63	-66.0	0x8E	-44.5	0xB9	-23.0	0xE4	-1.5
0x64	-65.5	0x8F	-44.0	0xBA	-22.5	0xE5	-1.0
0x65	-65.0	0x90	-43.5	0xBB	-22.0	0xE6	-0.5
0x66	-64.5	0x91	-43.0	0xBC	-21.5	0xE7	0.0
0x67	-64.0	0x92	-42.5	0xBD	-21.0	0xE8	0.5
0x68	-63.5	0x93	-42.0	0xBE	-20.5	0xE9	1.0
0x69	-63.0	0x94	-41.5	0xBF	-20.0	0xEA	1.5
0x6A	-62.5	0x95	-41.0	0xC0	-19.5	0xEB	2.0

0x6B	-62.0	0x96	-40.5	0xC1	-19.0	0xEC	2.5
0x6C	-61.5	0x97	-40.0	0xC2	-18.5	0xED	3.0
0x6D	-61.0	0x98	-39.5	0xC3	-18.0	0xEE	3.5
0x6E	-60.5	0x99	-39.0	0xC4	-17.5	0xEF	4.0
0x6F	-60.0	0x9A	-38.5	0xC5	-17.0	0xF0	4.5
0x70	-59.5	0x9B	-38.0	0xC6	-16.5	0xF1	5.0
0x71	-59.0	0x9C	-37.5	0xC7	-16.0	0xF2	5.5
0x72	-58.5	0x9D	-37.0	0xC8	-15.5	0xF3	6.0
0x73	-58.0	0x9E	-36.5	0xC9	-15.0	0xF4	6.5
0x74	-57.5	0x9F	-36.0	0xCA	-14.5	0xF5	7.0
0x75	-57.0	0xA0	-35.5	0xCB	-14.0	0xF6	7.5
0x76	-56.5	0xA1	-35.0	0xCC	-13.5	0xF7	8.0
0x77	-56.0	0xA2	-34.5	0xCD	-13.0	0xF8	8.5
0x78	-55.5	0xA3	-34.0	0xCE	-12.5	0xF9	9.0
0x79	-55.0	0xA4	-33.5	0xCF	-12.0	0xFA	9.5
0x7A	-54.5	0xA5	-33.0	0xD0	-11.5	0xFB	10.0
0x7B	-54.0	0xA6	-32.5	0xD1	-11.0	0xFC	10.5
0x7C	-53.5	0xA7	-32.0	0xD2	-10.5	0xFD	11.0
0x7D	-53.0	0xA8	-31.5	0xD3	-10.0	0xFE	11.5
0x7E	-52.5	0xA9	-31.0	0xD4	-9.5	0xFF	12.0
0x7F	-52.0	0xAA	-30.5	0xD5	-9.0		
0x80	-51.5	0xAB	-30.0	0xD6	-8.5		
0x81	-51.0	0xAC	-29.5	0xD7	-8.0		

## High Pass Filter2 Cut-off Control Register

MAPCON	INDEX		b07 (Initial)	b06	b05	b04	b03	b02	b01	b00
	R	W								
0x0	0x7e	0x7f	-	-	-	-	-	HPF2CUT		
			-	-	-	-	-	0	0	0

This register is to set the cut-off frequency of the high-pass filter for the noise reduction during recording.  
Don't change the setting of this register under the filter processing concerned(HPF2EN="1" and RELPLAY=0x1,0x3 or 0x7).

## HPF2CUT[2:0]

These set the cut-off frequency of the noise reduction high-pass filter during recording and the numerical value of below list expresses 1.5dB damping and 3dB damping frequency in each second order filter(HPF2OD="1") and one order filter (HPF2OD="0").

HPF2CUT [2:0]	Cut-off Frequency(Hz)		
	fs=8kHz, 16kHz, 32kHz	fs=11.025kHz, 22.05kHz, 44.1kHz	fs=12kHz, 24kHz, 48kHz
0x0	80	110	120
0x1	100	138	150
0x2	130	179	195
0x3	160	221	240
0x4	200	276	300
0x5	260	358	390
0x6	320	441	480
0x7	400	551	600

Programmable Equalizer Band0 Coefficient-a0 (L) Register  
 Programmable Equalizer Band0 Coefficient-a0 (H) Register  
 Programmable Equalizer Band0 Coefficient-a1 (L) Register  
 Programmable Equalizer Band0 Coefficient-a1 (H) Register  
 Programmable Equalizer Band1 Coefficient-a0 (L) Register  
 Programmable Equalizer Band1 Coefficient-a0 (H) Register  
 Programmable Equalizer Band1 Coefficient-a1 (L) Register  
 Programmable Equalizer Band1 Coefficient-a1 (H) Register  
 Programmable Equalizer Band2 Coefficient-a0 (L) Register  
 Programmable Equalizer Band2 Coefficient-a0 (H) Register  
 Programmable Equalizer Band2 Coefficient-a1 (L) Register  
 Programmable Equalizer Band2 Coefficient-a1 (H) Register  
 Programmable Equalizer Band3 Coefficient-a0 (L) Register  
 Programmable Equalizer Band3 Coefficient-a0 (H) Register  
 Programmable Equalizer Band3 Coefficient-a1 (L) Register  
 Programmable Equalizer Band3 Coefficient-a1 (H) Register  
 Programmable Equalizer Band4 Coefficient-a0 (L) Register  
 Programmable Equalizer Band4 Coefficient-a0 (H) Register  
 Programmable Equalizer Band4 Coefficient-a1 (L) Register  
 Programmable Equalizer Band4 Coefficient-a1 (H) Register

MAPCON	INDEX		b07 (Initial)	b06	b05	b04	b03	b02	b01	b00
	R	W								
0x0	0x80	0x81	EQ0A0L							
			0	0	0	0	0	0	0	0
0x0	0x82	0x83	EQ0A0H							
			0	0	0	0	0	0	0	0
0x0	0x84	0x85	EQ0A1L							
			0	0	0	0	0	0	0	0
0x0	0x86	0x87	EQ0A1H							
			0	0	0	0	0	0	0	0
0x0	0x88	0x89	EQ1A0L							
			0	0	0	0	0	0	0	0
0x0	0x8a	0x8b	EQ1A0H							
			0	0	0	0	0	0	0	0
0x0	0x8c	0x8d	EQ1A1L							
			0	0	0	0	0	0	0	0
0x0	0x8e	0x8f	EQ1A1H							
			0	0	0	0	0	0	0	0
0x0	0x90	0x91	EQ2A0L							
			0	0	0	0	0	0	0	0
0x0	0x92	0x93	EQ2A0H							
			0	0	0	0	0	0	0	0
0x0	0x94	0x95	EQ2A1L							
			0	0	0	0	0	0	0	0
0x0	0x96	0x97	EQ2A1H							
			0	0	0	0	0	0	0	0
0x0	0x98	0x99	EQ3A0L							
			0	0	0	0	0	0	0	0
0x0	0x9a	0x9b	EQ3A0H							
			0	0	0	0	0	0	0	0
0x0	0x9c	0x9d	EQ3A1L							
			0	0	0	0	0	0	0	0
0x0	0x9e	0x9f	EQ3A1H							
			0	0	0	0	0	0	0	0
0x0	0xa0	0xa1	EQ4A0L							
			0	0	0	0	0	0	0	0
0x0	0xa2	0xa3	EQ4A0H							
			0	0	0	0	0	0	0	0
0x0	0xa4	0xa5	EQ4A1L							
			0	0	0	0	0	0	0	0
0x0	0xa6	0xa7	EQ4A1H							
			0	0	0	0	0	0	0	0

MAPCON	INDEX		b07 (Initial)	b06	b05	b04	b03	b02	b01	b00
	R	W								
0x2	0x7e	0x7f	EQ0A0LB							
			0	0	0	0	0	0	0	0
0x2	0x80	0x81	EQ0A0HB							
			0	0	0	0	0	0	0	0
0x2	0x82	0x83	EQ0A1LB							
			0	0	0	0	0	0	0	0
0x2	0x84	0x85	EQ0A1HB							
			0	0	0	0	0	0	0	0
0x2	0x86	0x87	EQ1A0LB							
			0	0	0	0	0	0	0	0
0x2	0x88	0x89	EQ1A0HB							
			0	0	0	0	0	0	0	0
0x2	0x8a	0x8b	EQ1A1LB							
			0	0	0	0	0	0	0	0
0x2	0x8c	0x8d	EQ1A1HB							
			0	0	0	0	0	0	0	0
0x2	0x8e	0x8f	EQ2A0LB							
			0	0	0	0	0	0	0	0
0x2	0x90	0x91	EQ2A0HB							
			0	0	0	0	0	0	0	0
0x2	0x92	0x93	EQ2A1LB							
			0	0	0	0	0	0	0	0
0x2	0x94	0x95	EQ2A1HB							
			0	0	0	0	0	0	0	0
0x2	0x96	0x97	EQ3A0LB							
			0	0	0	0	0	0	0	0
0x2	0x98	0x99	EQ3A0HB							
			0	0	0	0	0	0	0	0
0x2	0x9a	0x9b	EQ3A1LB							
			0	0	0	0	0	0	0	0
0x2	0x9c	0x9d	EQ3A1HB							
			0	0	0	0	0	0	0	0
0x2	0x9e	0x9f	EQ4A0LB							
			0	0	0	0	0	0	0	0
0x2	0xa0	0xa1	EQ4A0HB							
			0	0	0	0	0	0	0	0
0x2	0xa2	0xa3	EQ4A1LB							
			0	0	0	0	0	0	0	0
0x2	0xa4	0xa5	EQ4A1HB							
			0	0	0	0	0	0	0	0

These registers are to set the coefficients a0 and a1 of each five band programmable equalizer. One coefficients value is specified by two bytes data. The centre frequency and band width of the filter can be set by changing these register value. Please don't change the register setting during corresponding filter operation  
EQ0A0L to EQ4A1H are became effective at COEFSEL=0 and EQ0A0LB to EQ4A1HB are became effective at COEFSEL=1.

The detailed setting value is described in the Filter function.

Zero Detection Setting Register

MAPCON	INDEX		b07 (Initial)	b06	b05	b04	b03	b02	b01	b00
	R	W								
0x0	0xdc	0xdd	ZDTIME				-	-	-	ZDEN
			0	0	0	0	-	-	-	0

This register controls zero detection for low power consumption mode. When zero detection is enable and "0" data are inputted in succession, a part of internal clock and speaker amplifier goes to disable to operate under low power consumption. Controlling a zero detection function for low power consumption mode movement, and enabling this function, some internal clocks stop it, and a speaker amplifier is disabled. When data, not 0 data, is input, the disable block starts operation again.

In addition, the zero detection is effective only speaker amplifier playing mode. In the other modes, please set ZDEN bit in "0".

ZDEN

Enables/Disables the zero detection function.

ZDEN	Explanation
0x0	A zero detection function is disabled.
0x1	A zero detection function is enabled.

ZEROTIM

Sets "0" detection period. When "0" continues more than the following set points in succession with LCH/RCH, it becomes low power consumption mode.

ZEROTIM	Explanation
0x00	256/fs
0x01	512/fs
0x02	1024/fs
0x03	2048/fs
0x04	4096/fs
0x05	8192/fs
0x06	16384/fs
0x07	32768/fs
0x08	65536/fs
0x09	131072/fs
0x0a	262144/fs
0x0b to 0x0f	This is prohibited from setting

MIC select Control Register

MAPCON	INDEX		b07 (Initial)	b06	b05	b04	b03	b02	b01	b00
	R	W								
0x0	0xe8	0xe9	-	-	-	-	-	-	MIN2EN	MIN1EN
			-	-	-	-	-	-	0	1

This register sets microphone input.

MIN1EN

Using MIN1 terminal in analog MIC.

Setting	Explanation
0	Does not use MIN1 terminal.
1	Use MIN1 terminal.

MIN2EN

Using MIN2 terminal in analog MIC. Please set it in "0" when in the differential mode.

Setting	Explanation
0	Does not use MIN2 terminal.
1	Use MIN2 terminal.

FPLL M setting Register  
 FPLL N Setting (L) Register  
 FPLL N Setting (H) Register  
 FPLL D Setting Register  
 FPLL F Setting (L) Register  
 FPLL F Setting (H) Register  
 FPLL F\_D Setting (L) Register  
 FPLL F\_D Setting (H) Register  
 FPLL V setting Register

MAPCON	INDEX		b07 (Initial)	b06	b05	b04	b03	b02	b01	b00
	R	W								
0x1	0x02	0x03	-	-	-	-	-	FPLLM		
			-	-	-	-	-	0	0	0
0x1	0x04	0x05	FPLLNL							
			0	0	0	0	0	0	0	0
0x1	0x06	0x07	-	-	-	-	-	-	-	FPLLNH
			-	-	-	-	-	-	-	0
0x1	0x08	0x09	-	-	-	FPLLD				
			-	-	-	0	0	0	0	0
0x1	0x0a	0x0b	FPLLFL							
			0	0	0	0	0	0	0	0
0x1	0x0c	0x0d	FPLLFH							
			0	0	0	0	0	0	0	0
0x1	0x0e	0x0f	FPLLFDL							
			0	0	0	0	0	0	0	0
0x1	0x10	0x11	FPLLFDH							
			0	0	0	0	0	0	0	0
0x1	0x12	0x13	-	-	-	-	FPLLV			
			-	-	-	-	0	0	0	0

This register sets the output frequency of PLL.

Please use your prepared clock setting register level that is computed separately using clock setting calculation tool.  
 The register set point and the relations of the output frequency are streets of the lower expression.

$$\text{PLL output frequency (Hz)} = \text{PLL input frequency} / \text{FPLLM} \times (\text{FPLLN} + \text{FPLLD}/16 + \text{FPLLF}/\text{FPLLF\_D}/16) \times 2 / \text{FPLLV}$$

Soft Clip Enable Register  
 Soft Clip Threshold H Register  
 Soft Clip Threshold M Register  
 Soft Clip Threshold L Register  
 Soft Clip Gain Register

MAPCON	INDEX		b07 (Initial)	b06	b05	b04	b03	b02	b01	b00
	R	W								
0x1	0x20	0x21	-	-	-	-	-	-	-	SCEN
			-	-	-	-	-	-	-	0
0x1	0x22	0x23	-	SCTHRH						
			-	0	0	0	0	0	0	0
0x1	0x24	0x25	SCTHRM							
			0	0	0	0	0	0	0	0
0x1	0x26	0x27	SCTHRL							
			0	0	0	0	0	0	0	0
0x1	0x28	0x29	-	-	-	-	-	SCGAIN		
			-	-	-	-	-	0	0	1

This register controls the soft clip function.

SCEN

Sets the soft clip enable.

Setting	Explanation
0	Disable
1	Enable

SCTHRH

SCTHRM

SCTHRL

This register sets the soft clip threshold level.

When PCM signal with more than of this bit is input, the LSI clips it according to a value of SCGAIN and works.

The value of threshold level is 23bit (SCTHRM [6:0], SCTHRM [7:0], and SCTHRL [7:0])

Please do not change the value of this bit during Soft Clip function movement.

SCGAIN

This sets the magnification during soft clip. In addition, please do not change the value of this bit during movement.

Setting	Explanation
0x0	Double
0x1	1 time (default)
0x2	1 double 1/2
0x3	1 double 1/4
0x4	1 double 1/8
0x5	1 double 1/16
0x6	1 double 1/32
0x7	1 double 1/64

Touch ADC Control Register

MAPCON	INDEX		b07 (Initial)	b06	b05	b04	b03	b02	b01	b00
	R	W								
1	0x60	0x61	TCHEN	TCHA2	TCHA1	TCHA0	-	TCHRSEL	TCHMODE	-
			0	1	1	1	1	0	0	-

This register controls the touch panel interface, and a light, please do "1" in bit 3.

TCHEN

This enables and disables the touch panel interface. In the case of "0", this bit is cleared after (an automatic mode in the case of enable), the lead of the AD conversion data of the touch panel interface TCHA2 bit by "0".

TCHEN	Explanation
0x0	A touch panel interface is disabled.
0x1	A touch panel interface is enabled.

TCHA2

It controls the convert mode of the touch panel interface, and, in the case of "1", this bit interrupts it after the lead of the AD conversion data of the touch panel interface automatically and changes in a mode. The next conversion starts by an automatic mode leading AD conversion result in the case of disable.

TCHA2	Explanation
0x0	An automatic mode is enabled.
0x1	An automatic mode is disabled.

TCHA1, TCHA0

This controls the convert mode of the touch panel interface.

TCHEN	TCHA2	TCHA1, TCHA0	Explanation
TCHEN=1	*	0x0	It becomes the X-axis measurement mode.
	*	0x1	It becomes the Y-axis measurement mode.
	*	0x2	It becomes the Z1 axis measurement mode.
	*	0x3	It becomes the Z2 axis measurement mode.
TCHEN=0	0x0	0x3	It becomes the interrupt mode.

## TCHRSEL

Choose interrupt pull up resistance using for one of a touch panel interface.

TCHRSEL	Explanation
0x0	I interrupt it, and pulling up resistance becomes 50kΩ.
0x1	I interrupt it, and pulling up resistance becomes 90kΩ.

## TCHMODE

Choose touch panel interface mode.

TCHMODE	Explanation
0x0	12Bit Mode
0x1	8Bit Mode

## Touch ADC result1 Register

## Touch ADC result2 Register

MAPCON	INDEX		b07 (Initial)	b06	b05	b04	b03	b02	b01	b00
	R	W								
0x1	0x62	0x63	ADCR1							
			0	0	0	0	0	0	0	0
0x1	0x64	0x65	ADCR2				-	-	-	-
			0	0	0	0	-	-	-	-

This register is to get analog-to-digital conversion data of the touch panel interface ADC. In the 12bit mode, please read register in order of ADCR1 (\$62h), ADCR2 (\$64h).

## TOUTCHAD1

This register is to get analog-to-digital conversion data of the touch panel interface ADC. In the 8 bit mode, please read only this register. In the 12 bit mode, this register is higher 8 bits of the 12bit ADC output data.

## TOUTCHAD2

This register is to get analog-to-digital conversion data of the touch panel interface ADC. In the 8 bit mode, this register value is "0". In the 12 bits mode, this register is lower 4 bits of the 12bit ADC output data.

## Headphone Amplifier Input Control Register

MAPCON	INDEX		b07 (Initial)	b06	b05	b04	b03	b02	b01	b00
	R	W								
0x1	0x82	0x83	-	-	HPRIN2EN	HPRIN1EN	-	-	-	HPLIN1EN
			-	-	0	0	-	-	-	0

This register is to set the input path of the headphones amplifier. Please do not set HPRIN1EN bit and the HPRIN2EN bit to "1" simultaneously. Please set only either bit to "1".

## HPLIN1EN

This bit is to set the input path of the Lch headphones amplifier.

HPLIN1EN	Explanation
0x0	Disconnect the output of Lch-DAC to Lch headphones amplifier.
0x1	Connect the output of Lch-DAC to Lch headphones amplifier.

## HPRIN1EN

This bit is to set the input path of the Rch headphones amplifier.

HPRIN1EN	Explanation
0x0	Disconnect the output of Lch-DAC to Rch headphones amplifier.
0x1	Connect the output of Lch-DAC to Rch headphones amplifier.

## HPRIN2EN

This bit is to set the input path of the Rch headphones amplifier.

HPRIN2EN	Explanation
0x0	Disconnect the output of Rch-DAC to Rch headphones amplifier.
0x1	Connect the output of Rch-DAC to Rch headphones amplifier.

## Speaker Amplifier Input Control Register

MAPCON	INDEX		b07 (Initial)	b06	b05	b04	b03	b02	b01	b00
	R	W								
0x1	0x84	0x85	-	-	-	-	SPIN2EN	SPIN1EN	SPVOL	
			-	-	-	-	0	0	0	0

This register is to set the input path and the volume of the speaker amplifier.

## SPVOL

This register is to set the volume level of the speaker amplifier.

SPVOL	Explanation
0x0	0dB
0x1	6dB
0x2	12dB
0x3	18dB

## SPIN1EN

This bit is to set the input path of the speaker amplifier.

SPIN1EN	Explanation
0x0	Disconnect the output of the Lch volume to a speaker amplifier.
0x1	Connect the output of the Lch volume to a speaker amplifier.

## SPIN2EN

This bit is to set the input path of the speaker amplifier.

SPIN2EN	Explanation
0x0	Disconnect the output of the Rch volume to a speaker amplifier.
0x1	Connect the output of the Rch volume to a speaker amplifier.

## Play Programmable LPF Setting Register

MAPCON	INDEX		b07 (Initial)	b06	b05	b04	b03	b02	b01	b00
	R	W								
0x1	0xa0	0xa1	-	-	-	-	-	-	PLPFOD	PLPFEN
			-	-	-	-	-	-	0	0

This register is to set "LPF" block for DAC-path (playback) in digital signal flow. This is to set Enable/Disable and filter order. This function is effective for DAC-path (playback) at "PLPFEN=1" and "SEMODE [7]=1".

## PLPFEN

This bit is to set Enable/Disable of low pass filter for DAC-path.

PLPFEN	Explanation
0	LPF for DAC-path is Disable
1	LPF for DAC-path is Enable

## PLPFOD

This bit is to set number of low pass filter order for DAC-path.

PLPFOD	Explanation
0	LPF for DAC-path is second-order
1	LPF for DAC-path is first-order

Play Programmable LPF Coef (L) Register  
Play Programmable LPF Coef (H) Register

MAPCON	INDEX		b07 (Initial)	b06	b05	b04	b03	b02	b01	b00
	R	W								
0x1	0xa2	0xa3	PLPFC0L							
			0	0	0	0	0	0	0	0
0x1	0xa4	0xa5	PLPFC0H							
			0	0	0	0	0	0	0	0

This register is to set "LPF" block for DAC-path (playback) in digital signal flow. This is to set Enable/Disable and filter order.

PLPFC0L [7:0] / PLPFC0H [7:0]

This bit is to set low pass filter cut off frequency for DAC-path.  
 This value has to change by sampling frequency.  
 Please use Filter Setting Calculation program for \*PLPFC0L / PLPFC0H setting.

Rec Programmable LPF Setting Register

MAPCON	INDEX		b07 (Initial)	b06	b05	b04	b03	b02	b01	b00
	R	W								
0x1	0xa6	0xa7	-	-	-	-	-	-	RLPFOD	RLPFEN
			-	-	-	-	-	-	0	0

This register is to set “LPF” block for ADC-path (record) in digital signal flow. This is to set Enable/Disable and filter order.  
 This function is exclusive to “HPF2” controlled by HPF2EN of DSP Filter Function Enable register.  
 This function is effective for ADC-path (record) at “RLPFEN=1” and “SEMODE [7] =1”.

RLPFEN

This bit is to set Enable/Disable of low pass filter for ADC-path.

RLPFEN	Explanation
0	LPF for DAC-path is Disable (HPF2 is available)
1	LPF for DAC-path is Enable (HPF2 is not available. HPF2EN-bit is not valid)

RLPFOD

This bit is to set number of low pass filter order for ADC-path.

RLPFOD	Explanation
0	LPF for ADC-path is second-order
1	LPF for ADC-path is first-order

Rec Programmable LPF Coef (L) Register  
 Rec Programmable LPF Coef (H) Register

MAPCON	INDEX		b07 (Initial)	b06	b05	b04	b03	b02	b01	b00
	R	W								
0x1	0xa8	0xa9	RLPFC0L							
			0	0	0	0	0	0	0	0
0x1	0xaa	0xab	RLPFC0H							
			0	0	0	0	0	0	0	0

This register is to set “LPF” block for ADC-path (playback) in digital signal flow.

Audio Analog Control2 Register

MAPCON	INDEX		b07 (initial)	b06	b05	b04	b03	b02	b01	b00
	R	W								
0x02	0x04	0x05	-	-	-	-	HPLSEN	-	-	-
			-	-	1	-	1	1	-	-

HPLSEN

This bit controls the level shifter for headphone amplifier.

Setting	Explanation
0x0	Disable the level shifter for headphone amplifier
0x1	Enable the level shifter for headphone amplifier

Audio Analog Control1 Register

MAPCON	INDEX		b07 (initial)	b06	b05	b04	b03	b02	b01	b00
	R	W								
0x02	0x12	0x13	-	-	-	-	-	-	-	AREF11EN
			-	-	-	-	-	-	-	1

## AREF11EN

This bit controls the reference current of the analog circuit for the audio block.

Setting	Explanation
0x0	Disable the reference current of the analog circuit for the audio block.
0x1	Enable the reference current of the analog circuit for the audio block.

## Register MAP Control Register

MAPCON	INDEX		b07 (Initial)	b06	b05	b04	b03	b02	b01	b00
	R	W								
0x2	0x1c	0x1d	-	-	-	-	-	-	MAPCON	
			-	-	-	-	-	-	0	0

## MAPCON

Please refer to a register map about the target register to change front and back side of the register map, and to be replaced by.

The register is to set register map. Please refer register map about the map of the changing object.

Setting	Explanation
0x0	It is accessible to register MAP0
0x1	It is accessible to register MAP1
0x2	It is accessible to register MAP2
0x3	Prohibit

## PLL External Components Setting Register

MAPCON	INDEX		b07 (Initial)	b06	b05	b04	b03	b02	b01	b00
	R	W								
2	0x00	0x01	-	-	-	-	-	-	-	EXMODE
			-	-	-	-	-	-	-	1

This register is to select use or not use the external filter for PLL.

## EXMODE

This register is to select use or not use the external filter for PLL. When you use PLL with BCLK clock as a clock source, please set it to "1" by all means.

EXMODE	Explanation
0x00	not use a external filter.
0x01	use a external filter.

Typical Performance Curves

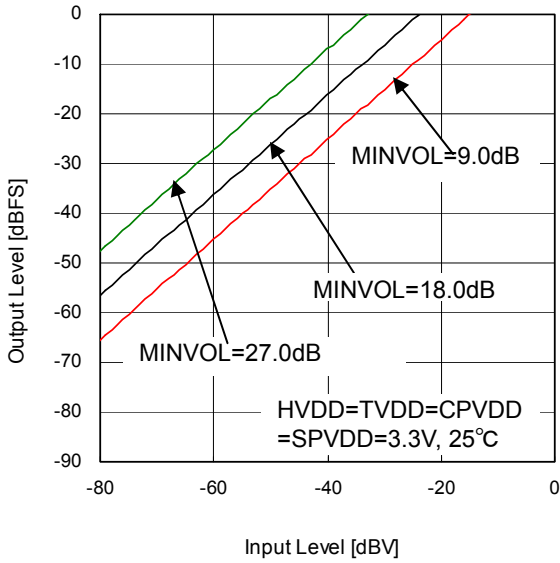

Figure 41. MIC Input Level [dBV] vs Output Level [dBFS]  
Analog Mic Input tot ADC out, PDATT=0

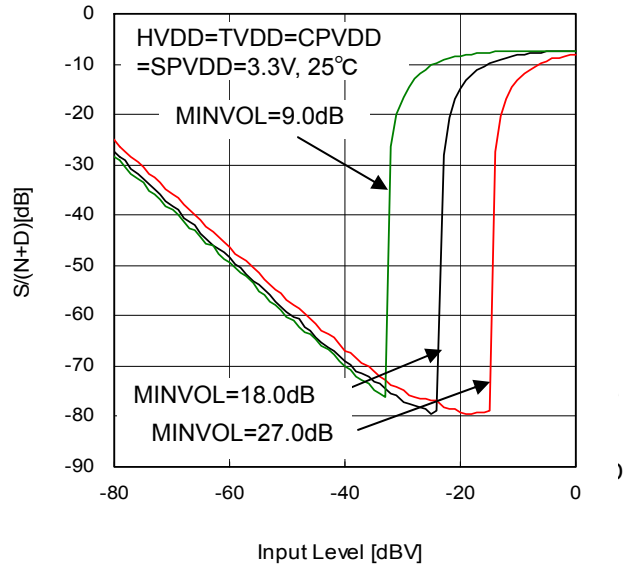

Figure 42. MIC Input Level [dBV] vs S/(N+D) [dBFS]  
Analog Mic Input tot ADC out, PDATT=0

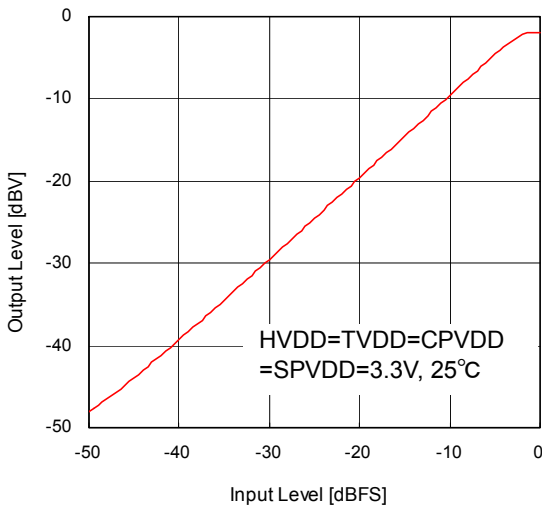

Figure 43. DAC input Level [dBFS] vs HPAMP Output Level [dB]

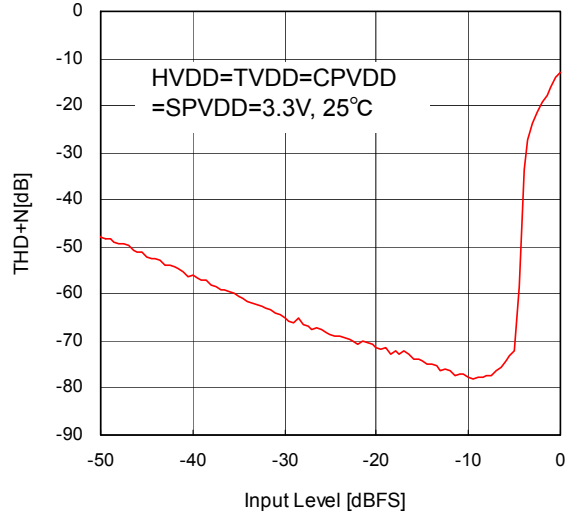

Figure 44. DAC input Level [dBFS] vs HPAMP THD+N [dB]

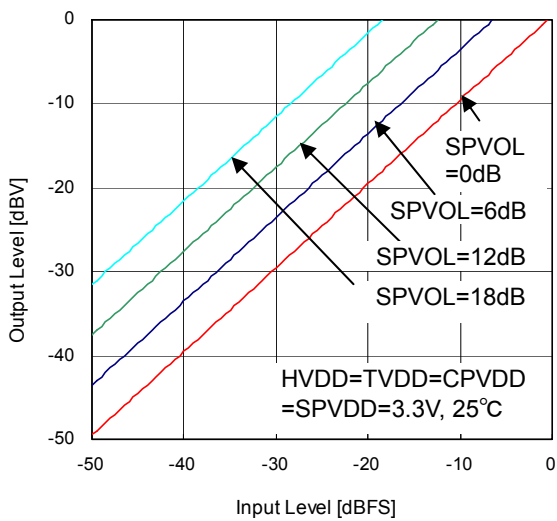

Figure 45. DAC input Level [dBFS] vs SPAMP-D Class Output Level [dB]

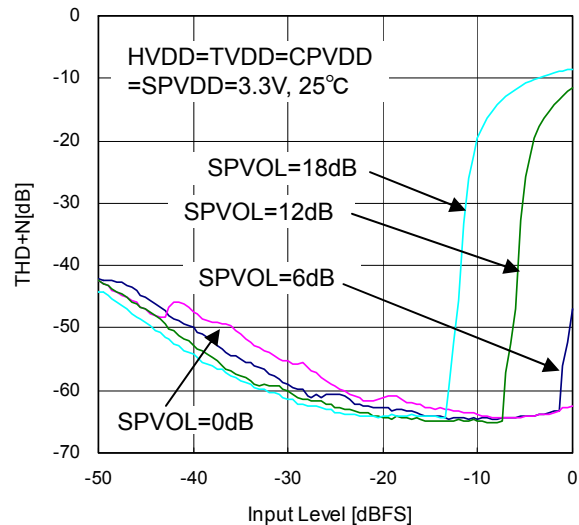

Figure 46. DAC input Level [dBFS] vs SPAMP-D Class THD+N [dB]

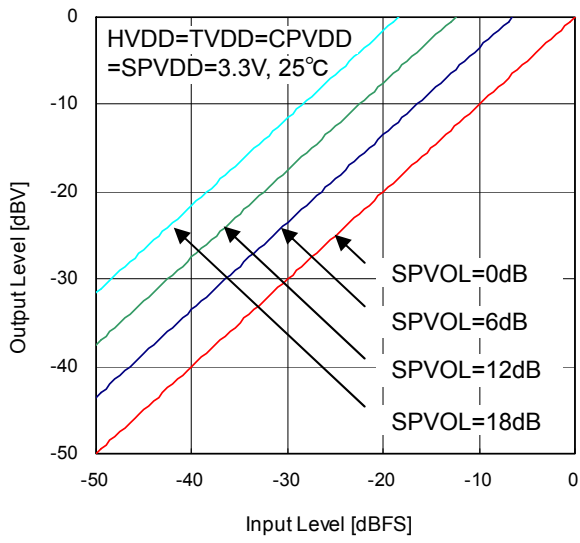

Figure 47. DAC input Level [dBFS] vs SPAMP-AB Class Output Level [dB]

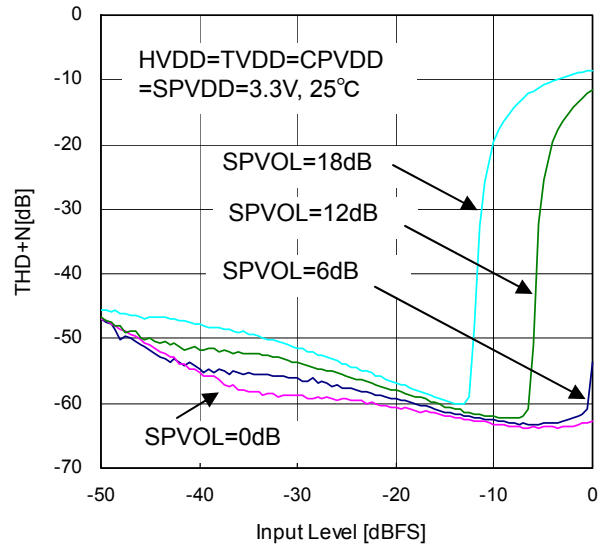

Figure 48. DAC input Level [dBFS] vs SPAMP-AB Class THD+N [dB]

Power dissipation

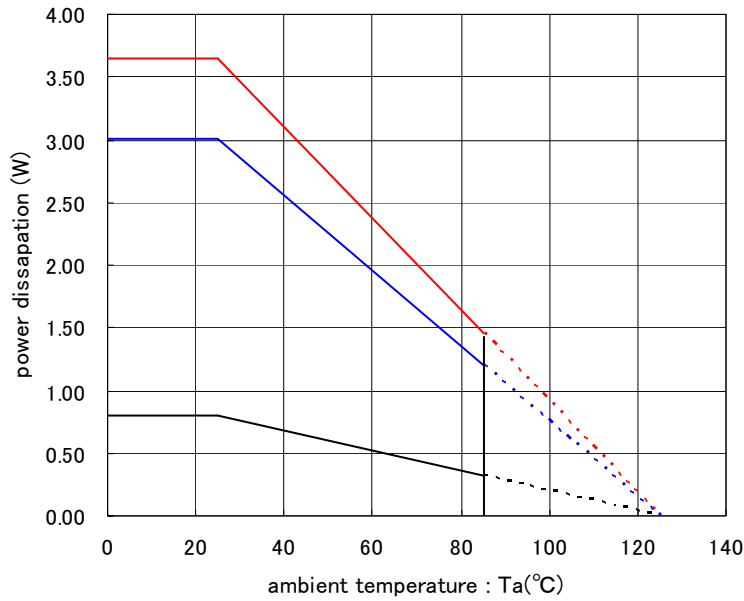

Figure 49.VQFN040V6060 Package

Measuring instrument: TH-156 (Kuwano Electrical)  
 Measuring status: PCB mounting(Rohm)  
 PCB size: 74.2mm × 74.2mm × 1.6mm (PCB with thermal via)  
 The quality of the material: FR4  
 The part of package bottom exposure heat sink connected PCB by solder.

PCB (1): 1-layer board (Size of copper foil on bottom: 23.69mm<sup>2</sup>),  $\theta_{ja} = 125.0^{\circ}\text{C/W}$   
 PCB (2): 4-layer board (Size of copper foil on top and bottom: 23.69mm<sup>2</sup>, 2nd and 3rd layer  
 Size of copper foil on bottom: 5505mm<sup>2</sup>),  $\theta_{ja} = 33.2^{\circ}\text{C/W}$   
 PCB (3): 4-layer board (Size of copper foil on bottom: 5505mm<sup>2</sup>),  $\theta_{ja} = 27.4^{\circ}\text{C/W}$

Please consider power dissipation by an actual using status, and perform the thermal design which has a margin enough. Although this product is exposing the frame on the bottom side of a package, heat dissipation processing is performed to this portion, and we assume raising and using heat dissipation efficiency. Please use not only PCB-top pattern but also PCB-bottom pattern, taking heat dissipation pattern as large as possible at it. Although D-class speaker amplifier have very high efficiency compared with the conventional analog-speaker amplifier and there is also little generation of heat, when continuous action is carried out by the maximum output power, actual power dissipation may exceed Pd. Please consider the thermal design enough so that power dissipation of averaging output power does not exceed Pd.

(Tjmax : Maximum junction temperature=125°C, Ta : Ambient temperature[°C],  $\theta_{ja}$  : Package thermal resistance[°C/W], Poav : Averaging output power[W],  $\eta$  : Efficiency)

Package Power dissipation Pd (W) = (Tjmax - Ta) /  $\theta_{ja}$   
 Circuit Power dissipation Pdiss (W) = Poav \* (1 /  $\eta$  - 1)

I/O equivalence circuit(s)

Terminal No.	Terminal Name	Terminal I/O	Terminal Power	Equivalent Circuit
1 40	HPL HPR	O	HPVDD	
2	HPVDD	O	CPVDD	
4	HPVSS	O	CPVDD	
5	CPN	O	CPVDD	
6	SPVDD	-	SPVDD	
7 8	SDOUT+ SPOUT-	O	SPVDD	

Terminal No.	Terminal Name	Terminal I/O	Terminal Power	Equivalent Circuit
9	SPGND	-	-	<p>SPVDD</p>
10	VMID	O	REGOUT	<p>REGOUT</p> <p>REGOUT</p> <p>HGND2</p> <p>HGND2</p>
11	MICBIAS CAP	O	HVDD	<p>HVDD</p> <p>HGND2</p> <p>HGND2</p>
12 13	MIN1 MIN2	I	REGOUT	<p>REGOUT</p> <p>HGND1</p>
14	HGND2	-	-	<p>REGOUT</p> <p>HVDD</p>
15	HGND1	-	-	<p>REGOUT</p> <p>HVDD</p>
16	N.C	-	-	

Terminal No.	Terminal Name	Terminal I/O	Terminal Power	Equivalent Circuit
17	HVDD	-	HVDD	
18	REGOUT	-	HVDD	
19	PLLC	O	REGOUT	
20	RESETB	I	HVDD	
21 30	TSTO IRQB	O	HVDD	
22 23 25 28	MCLKI CSB/SCL SCLK/SAD SAI_SDIN	I	HVDD	

Terminal No.	Terminal Name	Terminal I/O	Terminal Power	Equivalent Circuit
24 26 27	SDATA/SDA SAI_LRCLK SAI_BCLK	IO	HVDD	
31 32 33 34	YP XP XN YN	O	TVDD	
35	TGND	-	-	
36	TVDD	-	TVDD	
37	HPCOM	-	-	
38	CPVDD	-	CPVDD	

Terminal No.	Terminal Name	Terminal I/O	Terminal Power	Equivalent Circuit
39	CPP	-	CPVDD	

## Operational Notes

- 1) Absolute Maximum Ratings  
An excess in the absolute maximum ratings, such as supply voltage, temperature range of operating conditions, etc., can break down devices, thus don't exceed the absolute maximum ratings of supply voltage, temperature. If any special mode exceeding the absolute maximum ratings is assumed, consideration should be given to take physical safety measures including the use of fuses, etc.
- 2) GND voltage  
Make setting of the potential of the GND terminal so that it will be maintained at the minimum in any operating state.
- 3) Short circuit between terminals and erroneous mounting  
In order to mount ICs on a set PCB, pay thorough attention to the direction and offset of the ICs. Erroneous mounting can break down the ICs. Furthermore, if a short circuit occurs due to foreign matters entering between terminals or between the terminal and the power supply or the GND terminal, the ICs can break down.
- 4) Operation in strong electromagnetic field  
Be noted that using ICs in the strong electromagnetic field can malfunction them.
- 5) Thermal design  
If use speaker amplifier function, please consider power dissipation by an actual using status, and perform the thermal design which have a margin enough. If an input signal is made excessive in the state with insufficient heat dissipation, desired output power may not only be securable, but the thermal shutdown may operate.
- 6) Thermal shutdown  
This IC has the thermal shutdown circuit. If the thermal shutdown operates, speaker output terminal and line output terminal will stop in the open state(high impedance state).The thermal shutdown is only a function for suspending the output operation of IC to the last at the time of the thermal run-away under the abnormal condition in which chip temperature( $T_{jmax}$ ) exceeded 170 degrees. It is a circuit to protect IC, and the purpose is not offering protection and a guarantee of the set.
- 7) Short protection of output terminals  
This IC has the short protect function for output terminals. If the short protect function operates, output terminal will be latched and stop in the open state(high impedance state).After a stop, even if a short state is removed, it does not return to normal operation automatically. Please once turn off a power supply or a shutdown signal to make it return, and let turn on again and reboot.
- 8) Operating condition  
Operating voltage and operating temperature are ranges which perform basic function. Electrical characteristics and absolute maximum rating are not guaranteed in full voltage range or full temperature range.
- 9) Electrical characteristics specification  
Each audio characteristic specification, such as limit output power, total harmonic distortion shows the standard performance of the device, and depends for it on board layout / use parts / power supply part greatly.  
Typical specification value is a value when a device and each parts are directly mounted in the board of Rohm's standard.
- 10) Power supply  
Large peak current rushes into a SPVDD power supply line at the time of ClassD speaker amplifier use.  
The audio characteristic is affected by the value of a power supply decoupling capacitor, and layout.  
The power supply decoupling capacitor should be layouted (1uF or more) with sufficiently low ESR (equivalent series resistance) to most close of IC terminal.  
Moreover, in the design of a board pattern, the wiring of a power supply / GND line should become low impedance. In that case, even if digital power supply and analog power supply are same potential, please divide the digital power pattern and the analog power pattern and reduce a surroundings lump of the digital noise to the analog power supply by the common impedance of a wiring pattern.  
Please take the same pattern design into consideration also about a GND line. Moreover, while inserting a capacitor between power supply-GND terminals about all the power supply terminals of LSI, and please determine the value of capacitor after sufficient confirmation that there is no problem in the characteristics of capacitors to be used (a capacity omission happens at low temperature) in the case of electrolytic capacitors use.
- 11) External capacitor  
In order to use a ceramic capacitor as the external capacitor, determine the constant with consideration given to a degradation in the nominal capacitance due to DC bias and changes in the capacitance due to temperature, etc.
- 12) Status of this document

The Japanese version of this document is formal specification. A customer may use this translation version only for a reference to help reading the formal version.  
If there are any differences in translation version of this document formal version takes priority.

Ordering Information

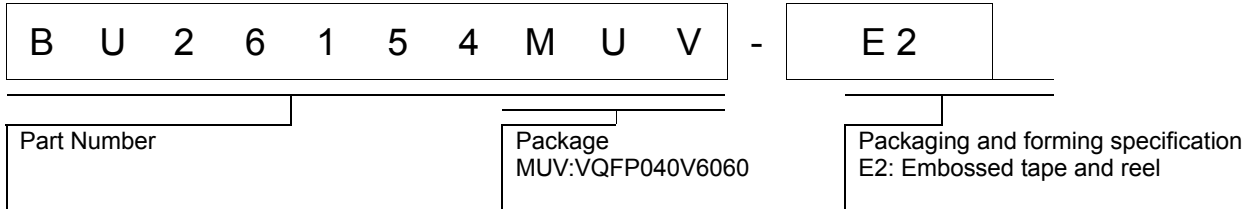

Physical Dimension, Tape and Reel Information

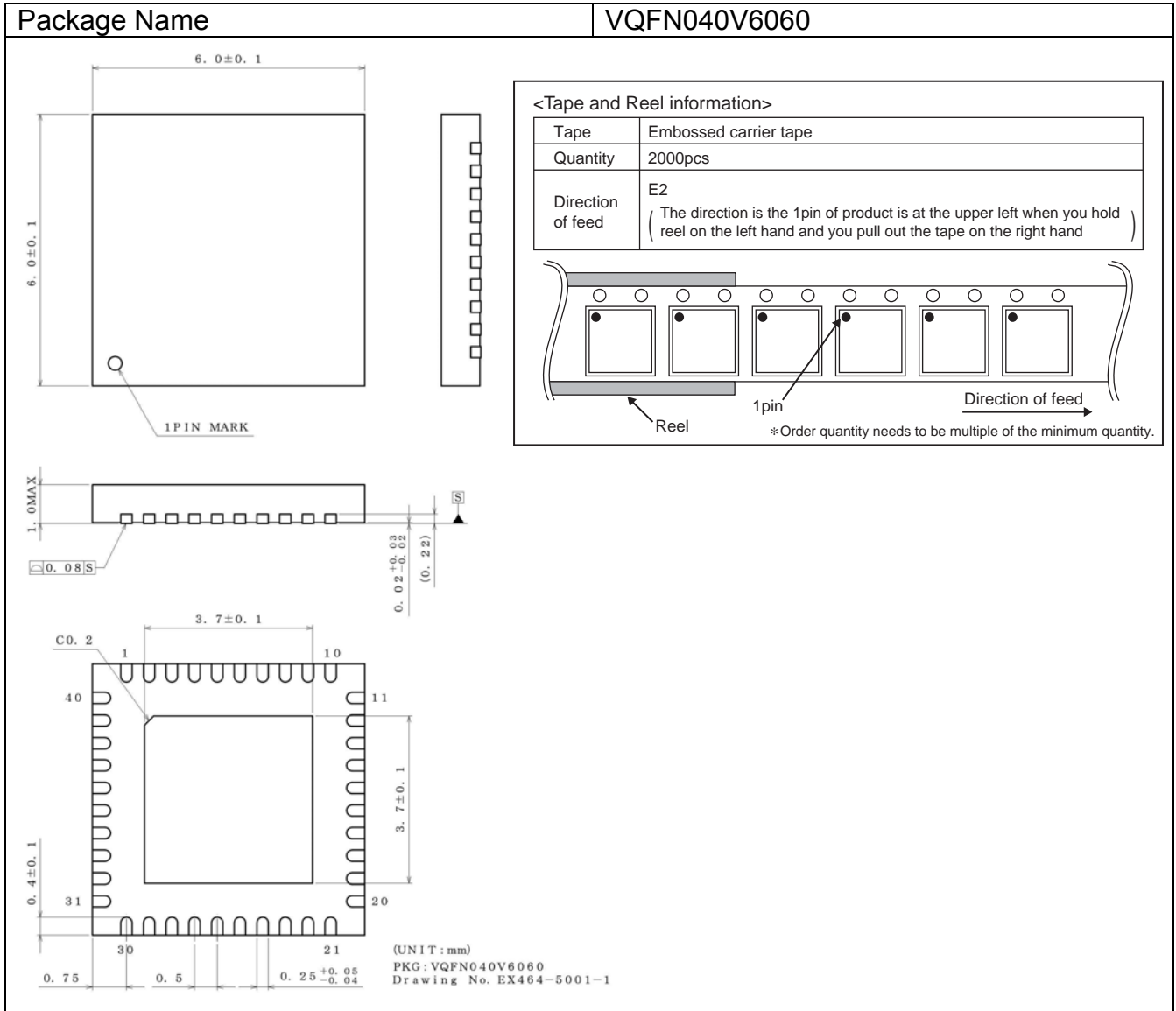

Marking Diagrams

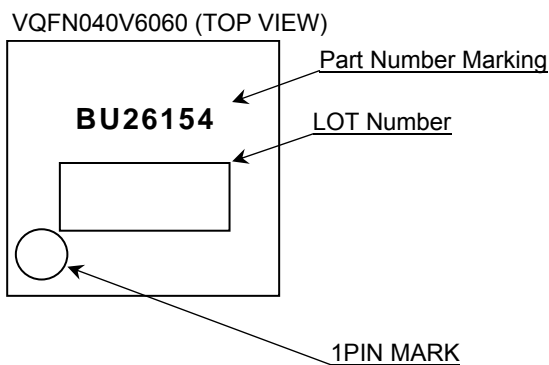

## Revision History

Date	Revision	Changes
23.Jun.2014	001	Rev.001 First revision release
26.Oct.2015	002	P1. Change the Height of Package P4. Change the application circuit P13. Change the VMIC reference voltage (SPVDD=> HVDD) P38, P48,P49,P50,P51,P73 Register function explanation and register details explanation <ul style="list-style-type: none"><li>- Removed MCLKOE bit and ADCREN bit,</li><li>- Added Analog Input Power Management, Speaker Amplifier Power Management registers MAPCON setting</li><li>- Changed ZCEN explanation(PDATT =&gt; EFFECT VOLUME)</li><li>- Added the explanation of Playback Digital Attenuator Control Register /B "FFh setting"</li><li>- Changed HPLSEN bit of Audio analog control2 register</li></ul>

# Notice

## Precaution on using ROHM Products

- Our Products are designed and manufactured for application in ordinary electronic equipments (such as AV equipment, OA equipment, telecommunication equipment, home electronic appliances, amusement equipment, etc.). If you intend to use our Products in devices requiring extremely high reliability (such as medical equipment <sup>(Note 1)</sup>, transport equipment, traffic equipment, aircraft/spacecraft, nuclear power controllers, fuel controllers, car equipment including car accessories, safety devices, etc.) and whose malfunction or failure may cause loss of human life, bodily injury or serious damage to property ("Specific Applications"), please consult with the ROHM sales representative in advance. Unless otherwise agreed in writing by ROHM in advance, ROHM shall not be in any way responsible or liable for any damages, expenses or losses incurred by you or third parties arising from the use of any ROHM's Products for Specific Applications.

(Note1) Medical Equipment Classification of the Specific Applications

JAPAN	USA	EU	CHINA
CLASS III	CLASS III	CLASS II b	CLASS III
CLASS IV		CLASS III	

- ROHM designs and manufactures its Products subject to strict quality control system. However, semiconductor products can fail or malfunction at a certain rate. Please be sure to implement, at your own responsibilities, adequate safety measures including but not limited to fail-safe design against the physical injury, damage to any property, which a failure or malfunction of our Products may cause. The following are examples of safety measures:
  - Installation of protection circuits or other protective devices to improve system safety
  - Installation of redundant circuits to reduce the impact of single or multiple circuit failure
- Our Products are designed and manufactured for use under standard conditions and not under any special or extraordinary environments or conditions, as exemplified below. Accordingly, ROHM shall not be in any way responsible or liable for any damages, expenses or losses arising from the use of any ROHM's Products under any special or extraordinary environments or conditions. If you intend to use our Products under any special or extraordinary environments or conditions (as exemplified below), your independent verification and confirmation of product performance, reliability, etc. prior to use, must be necessary:
  - Use of our Products in any types of liquid, including water, oils, chemicals, and organic solvents
  - Use of our Products outdoors or in places where the Products are exposed to direct sunlight or dust
  - Use of our Products in places where the Products are exposed to sea wind or corrosive gases, including Cl<sub>2</sub>, H<sub>2</sub>S, NH<sub>3</sub>, SO<sub>2</sub>, and NO<sub>2</sub>
  - Use of our Products in places where the Products are exposed to static electricity or electromagnetic waves
  - Use of our Products in proximity to heat-producing components, plastic cords, or other flammable items
  - Sealing or coating our Products with resin or other coating materials
  - Use of our Products without cleaning residue of flux (even if you use no-clean type fluxes, cleaning residue of flux is recommended); or Washing our Products by using water or water-soluble cleaning agents for cleaning residue after soldering
  - Use of the Products in places subject to dew condensation
- The Products are not subject to radiation-proof design.
- Please verify and confirm characteristics of the final or mounted products in using the Products.
- In particular, if a transient load (a large amount of load applied in a short period of time, such as pulse. is applied, confirmation of performance characteristics after on-board mounting is strongly recommended. Avoid applying power exceeding normal rated power; exceeding the power rating under steady-state loading condition may negatively affect product performance and reliability.
- De-rate Power Dissipation depending on ambient temperature. When used in sealed area, confirm that it is the use in the range that does not exceed the maximum junction temperature.
- Confirm that operation temperature is within the specified range described in the product specification.
- ROHM shall not be in any way responsible or liable for failure induced under deviant condition from what is defined in this document.

## Precaution for Mounting / Circuit board design

- When a highly active halogenous (chlorine, bromine, etc.) flux is used, the residue of flux may negatively affect product performance and reliability.
- In principle, the reflow soldering method must be used on a surface-mount products, the flow soldering method must be used on a through hole mount products. If the flow soldering method is preferred on a surface-mount products, please consult with the ROHM representative in advance.

For details, please refer to ROHM Mounting specification

**Precautions Regarding Application Examples and External Circuits**

1. If change is made to the constant of an external circuit, please allow a sufficient margin considering variations of the characteristics of the Products and external components, including transient characteristics, as well as static characteristics.
2. You agree that application notes, reference designs, and associated data and information contained in this document are presented only as guidance for Products use. Therefore, in case you use such information, you are solely responsible for it and you must exercise your own independent verification and judgment in the use of such information contained in this document. ROHM shall not be in any way responsible or liable for any damages, expenses or losses incurred by you or third parties arising from the use of such information.

**Precaution for Electrostatic**

This Product is electrostatic sensitive product, which may be damaged due to electrostatic discharge. Please take proper caution in your manufacturing process and storage so that voltage exceeding the Products maximum rating will not be applied to Products. Please take special care under dry condition (e.g. Grounding of human body / equipment / solder iron, isolation from charged objects, setting of Ionizer, friction prevention and temperature / humidity control).

**Precaution for Storage / Transportation**

1. Product performance and soldered connections may deteriorate if the Products are stored in the places where:
  - [a] the Products are exposed to sea winds or corrosive gases, including Cl<sub>2</sub>, H<sub>2</sub>S, NH<sub>3</sub>, SO<sub>2</sub>, and NO<sub>2</sub>
  - [b] the temperature or humidity exceeds those recommended by ROHM
  - [c] the Products are exposed to direct sunshine or condensation
  - [d] the Products are exposed to high Electrostatic
2. Even under ROHM recommended storage condition, solderability of products out of recommended storage time period may be degraded. It is strongly recommended to confirm solderability before using Products of which storage time is exceeding the recommended storage time period.
3. Store / transport cartons in the correct direction, which is indicated on a carton with a symbol. Otherwise bent leads may occur due to excessive stress applied when dropping of a carton.
4. Use Products within the specified time after opening a humidity barrier bag. Baking is required before using Products of which storage time is exceeding the recommended storage time period.

**Precaution for Product Label**

QR code printed on ROHM Products label is for ROHM's internal use only.

**Precaution for Disposition**

When disposing Products please dispose them properly using an authorized industry waste company.

**Precaution for Foreign Exchange and Foreign Trade act**

Since concerned goods might be fallen under listed items of export control prescribed by Foreign exchange and Foreign trade act, please consult with ROHM in case of export.

**Precaution Regarding Intellectual Property Rights**

1. All information and data including but not limited to application example contained in this document is for reference only. ROHM does not warrant that foregoing information or data will not infringe any intellectual property rights or any other rights of any third party regarding such information or data.
2. ROHM shall not have any obligations where the claims, actions or demands arising from the combination of the Products with other articles such as components, circuits, systems or external equipment (including software).
3. No license, expressly or implied, is granted hereby under any intellectual property rights or other rights of ROHM or any third parties with respect to the Products or the information contained in this document. Provided, however, that ROHM will not assert its intellectual property rights or other rights against you or your customers to the extent necessary to manufacture or sell products containing the Products, subject to the terms and conditions herein.

**Other Precaution**

1. This document may not be reprinted or reproduced, in whole or in part, without prior written consent of ROHM.
2. The Products may not be disassembled, converted, modified, reproduced or otherwise changed without prior written consent of ROHM.
3. In no event shall you use in any way whatsoever the Products and the related technical information contained in the Products or this document for any military purposes, including but not limited to, the development of mass-destruction weapons.
4. The proper names of companies or products described in this document are trademarks or registered trademarks of ROHM, its affiliated companies or third parties.

**General Precaution**

1. Before you use our Products, you are requested to carefully read this document and fully understand its contents. ROHM shall not be in any way responsible or liable for failure, malfunction or accident arising from the use of any ROHM's Products against warning, caution or note contained in this document.
2. All information contained in this document is current as of the issuing date and subject to change without any prior notice. Before purchasing or using ROHM's Products, please confirm the latest information with a ROHM sales representative.
3. The information contained in this document is provided on an "as is" basis and ROHM does not warrant that all information contained in this document is accurate and/or error-free. ROHM shall not be in any way responsible or liable for any damages, expenses or losses incurred by you or third parties resulting from inaccuracy or errors of or concerning such information.

# Mouser Electronics

Authorized Distributor

Click to View Pricing, Inventory, Delivery & Lifecycle Information:

[ROHM Semiconductor:](#)

[BU26154MUV-E2](#)