



IA186EM/IA188EM 8-Bit/16-Bit Microcontrollers

Data Sheet

Copyright © 2011 by Innovasic Semiconductor, Inc.

Published by Innovasic Semiconductor, Inc.
3737 Princeton Drive NE, Suite 130, Albuquerque, NM 87107

AMD, Am186, and Am188 are trademarks of Advanced Micro Devices, Inc.
MILES™ is a trademark of Innovasic Semiconductor, Inc.

TABLE OF CONTENTS

List of Figures	8
List of Tables	9
Conventions	12
Acronyms and Abbreviations	13
1. Introduction.....	14
1.1 General Description.....	14
1.2 Features	14
2. Packaging , Pin Descriptions, and Physical Dimensions.....	15
2.1 Packages and Pinouts	15
2.1.1 IA186EM TQFP Package	16
2.1.2 IA188EM TQFP Package	19
2.1.3 TQFP Physical Dimensions.....	22
2.1.4 IA186EM PQFP Package	23
2.1.5 IA188EM PQFP Package	26
2.1.6 PQFP Physical Dimensions	29
2.2 Pin Descriptions	30
2.2.1 a19/pio9, a18/pio8, a17/pio7, a16–a0—Address Bus (synchronous outputs with tristate)	30
2.2.2 ad15–ad8 (IA186EM)—Address/data bus (level-sensitive synchronous inouts with tristate).....	30
2.2.3 ad7–ad0—Address/Data bus (level-sensitive synchronous inouts with tristate)	30
2.2.4 ao15–ao8 (IA188EM)—Address-only bus (level-sensitive synchronous outputs with tristate).....	30
2.2.5 ale—Address Latch Enable (synchronous output)	31
2.2.6 ardy—Asynchronous Ready (level-sensitive asynchronous input).....	31
2.2.7 bhe_n/aden_n (IA186EM)—Bus High Enable (synchronous output with tristate)/Address Enable (input with internal pull-up).....	31
2.2.8 clkouta—Clock Output A (synchronous output).....	32
2.2.9 clkoutb—Clock Output B (synchronous output).....	32
2.2.10 den_n/pio5—Data Enable Strobe (synchronous output with tristate).....	32
2.2.11 drq1/pio12–drq0/pio13—DMA Requests (synchronous level-sensitive inputs)	32
2.2.12 dt/r_n/pio4—Data Transmit or Receive (synchronous output with tristate)	32
2.2.13 gnd—Ground	32
2.2.14 hlda—Bus Hold Acknowledge (synchronous output).....	33
2.2.15 hold—Bus Hold Request (synchronous level-sensitive input).....	33
2.2.16 int0—Maskable Interrupt Request 0 (asynchronous input).....	33
2.2.17 int1/select_n—Maskable Interrupt Request 1/Slave Select (both are asynchronous inputs)	33

2.2.18	int2/inta0_n/pio31—Maskable Interrupt Request 2 (asynchronous input)/Interrupt Acknowledge 0 (synchronous output)	34
2.2.19	int3/inta1_n/irq—Maskable Interrupt Request 3 (asynchronous input)/Interrupt Acknowledge 1 (synchronous output)/Interrupt Acknowledge (synchronous output)	34
2.2.20	int4/pio30—Maskable Interrupt Request 4 (asynchronous input).....	34
2.2.21	lcs_n/once0_n—Lower Memory Chip Select (synchronous output with internal pull-up)/ONCE Mode Request (input)	35
2.2.22	mcs2_n—mcs0_n (no pio, pio15, pio 14)—Midrange Memory Chip Selects (synchronous outputs with internal pull-up)	35
2.2.23	mcs3_n/rfsh_n (pio25)—Midrange Memory Chip Select (synchronous output with internal pull-up)/Automatic Refresh (synchronous output)	35
2.2.24	nmi—Nonmaskable Interrupt (synchronous edge-sensitive input)	35
2.2.25	pcs3_n—pcs0_n (pio19—pio16)—Peripheral Chip Selects 3–0 (synchronous outputs).....	36
2.2.26	pcs5_n/a1—Peripheral Chip Select 5 (synchronous output)/Latched Address Bit 1 (synchronous output)	36
2.2.27	pcs6_n/a2—Peripheral Chip Select 6 (synchronous output)/latched Address Bit 2 (synchronous output)	36
2.2.28	pio31—pio0—Programmable I/O Pins (asynchronous input/output open-drain).....	37
2.2.29	rd_n—Read strobe (synchronous output with tristate).....	37
2.2.30	res_n—Reset (asynchronous level-sensitive input).....	37
2.2.31	rfsh2_n/aden_n (IA188EM)—Refresh 2 (synchronous output with tristate)/Address Enable (input with internal pull-up)	37
2.2.32	rxd/pio28—Receive Data (asynchronous input)	37
2.2.33	s2_n—s0_n—Bus Cycle Status (synchronous outputs with tristate)	38
2.2.34	s6/clkdiv2_n/pio29—Bus Cycle Status Bit 6 (synchronous output)/Clock Divide by 2 (input with internal pull-up)	38
2.2.35	sclk—Serial Clock (synchronous outputs with tristate)	38
2.2.36	sdata—Serial Data (synchronous inout)	39
2.2.37	sden1—sden0—Serial Data Enables (synchronous outputs with tristate)	39
2.2.38	srdy/pio6—Synchronous Ready (synchronous level-sensitive input).....	39
2.2.39	tmrin0/pio11—Timer Input 0 (synchronous edge-sensitive input)	39
2.2.40	tmrin1/pio0—Timer Input 1 (synchronous edge-sensitive input)	39
2.2.41	tmrout0/pio10—Timer Output 0 (synchronous output)	39
2.2.42	tmrout1/pio1—Timer Output 1 (synchronous output)	39
2.2.43	txd/pio22—Transmit Data (asynchronous output)	39
2.2.44	ucs_n/once1_n—Upper Memory Chip Select (synchronous output)/ONCE Mode Request 1 (input with internal pull-up).....	40
2.2.45	uzi_n/pio26—Upper Zero Indicate (synchronous output).....	40

2.2.46	v_{cc} —Power Supply (input).....	40
2.2.47	whb_n (IA186EM)—Write High Byte (synchronous output with tristate)	40
2.2.48	wlb_n/wb_n—Write Low Byte (IA186EM) (synchronous output with tristate)/Write Byte (IA188EM) (synchronous output with tristate)	40
2.2.49	wr_n—Write Strobe (synchronous output)	41
2.2.50	x1—Crystal Input (input)	41
2.2.51	x2—Crystal Input (input)	41
2.3	Pins Used by Emulators	41
3.	Maximum Ratings, Thermal Characteristics, and DC Parameters	42
4.	Device Architecture	43
4.1	Bus Interface and Control	43
4.2	Clock and Power Management	45
4.3	System Clocks	45
4.4	Power-Save Mode	46
4.5	Initialization and Reset	46
4.6	Reset Configuration Register	46
4.7	Chip Selects	47
4.8	Chip-Select Timing	47
4.9	Ready- and Wait-State Programming	47
4.10	Chip Select Overlap	47
4.11	Upper Memory Chip Select.....	48
4.12	Low Memory Chip Select	49
4.13	Midrange Memory Chip Selects	49
4.14	Peripheral Chip Selects	49
4.15	Refresh Control	50
4.16	Interrupt Control.....	50
4.16.1	Interrupt Types.....	51
4.17	Timer Control.....	52
4.18	Direct Memory Access (DMA).....	52
4.19	DMA Operation.....	53
4.20	DMA Channel Control Registers	53
4.21	DMA Priority	54
4.22	Asynchronous Serial Port.....	54
4.23	Synchronous Serial Port.....	55
4.24	Programmable I/O (PIO).....	55
5.	Peripheral Architecture.....	57
5.1	Control and Registers	57
5.1.1	RELREG (0feh)	59
5.1.2	RESCON (0f6h).....	59
5.1.3	PRL (0f4h).....	59
5.1.4	PDCON (0f0h).....	60
5.1.5	EDRAM (0e4h)	61

5.1.6	CDRAM (0e2h)	61
5.1.7	MDRAM (0e0h)	62
5.1.8	D1CON (0dah) and D0CON (0cah)	62
5.1.9	D1TC (0d8h) and D0TC (0c8h)	64
5.1.10	D1DSTH (0d6h) and D0DSTH (0c6h)	64
5.1.11	DIDSTL (0d4h) and D0DSTL (0c4h)	65
5.1.12	D1SRCH (0d2h) and D0SRCH (0c2h)	65
5.1.13	D1SRCL (0d0h) and D0SRCL (0c0h)	66
5.1.14	MPCS (0a8h)	66
5.1.15	MMCS (0a6h)	67
5.1.16	PACS (0a4h)	68
5.1.17	LMCS (0a2h)	70
5.1.18	UMCS (0a0h)	71
5.1.19	SPBAUD (088h)	72
5.1.20	SPRD (086h)	73
5.1.21	SPTD (084h)	74
5.1.22	SPSTS (082h)	74
5.1.23	SPCT (080h)	75
5.1.24	PDATA1 (07ah) and PDATA0 (074h)	77
5.1.25	PDIR1 (078h) and PDIR0 (072h)	79
5.1.26	PIOMODE1 (076h) and PIOMODE0 (070h)	79
5.1.27	T1CON (05eh) and T0CON (056h)	80
5.1.28	T2CON (066h)	81
5.1.29	T2COMPA (062h), T1COMPB (05ch), T1COMPA (05ah), T0COMPB (054h), and T0COMPA (052h)	82
5.1.30	T2CNT (060h), T1CNT (058h), and T0CNT (050h)	83
5.1.31	SPICON (044h) (Master Mode)	83
5.1.32	WDCON (044h) (Master Mode)	84
5.1.33	I4CON (040h) (Master Mode)	84
5.1.34	I3CON (03eh) and I2CON (03ch) (Master Mode)	85
5.1.35	I1CON (03ah) and I0CON (038h) (Master Mode)	85
5.1.36	TCUCON (032h) (Master Mode)	86
5.1.37	T2INTCON (03ah), T1INTCON (038h), and T0INTCON (032h) (Slave Mode)	87
5.1.38	DMA1CON/INT6CON (036h) and DMA0CON/INT5CON (034h) (Master Mode)	87
5.1.39	DMA1CON/INT6 (036h) and DMA0CON/INT5 (034h) (Slave Mode)	87
5.1.40	INTSTS (030h) (Master Mode)	88
5.1.41	INTSTS (030h) (Slave Mode)	88
5.1.42	REQST (02eh) (Master Mode)	89
5.1.43	REQST (02eh) (Slave Mode)	90
5.1.44	INSERV (02ch) (Master Mode)	90

5.1.45	INSERV (02ch) (Slave Mode).....	91
5.1.46	PRIMSK (02ah) (Master and Slave Mode)	92
5.1.47	IMASK (028h) (Master Mode).....	92
5.1.48	IMASK (028h) (Slave Mode).....	93
5.1.49	POLLST (026h) (Master Mode).....	94
5.1.50	POLL (024h) (Master Mode).....	94
5.1.51	EOI (022h) End-Of-Interrupt Register (Master Mode)	95
5.1.52	EOI (022h) Specific End-Of-Interrupt Register (Slave Mode)	95
5.1.53	INTVEC (020h) Interrupt Vector Register (Slave Mode).....	96
5.1.54	SSR (018h).....	96
5.1.55	SSD0 (016h) and SSD0 (014h).....	96
5.1.56	SSC (012h).....	97
5.1.57	SSS (010h).....	97
5.2	Reference Documents	98
6.	AC Specifications	98
7.	Instruction Set Summary Table	126
7.1	Key to Abbreviations Used in Instruction Set Summary Table	136
7.1.1	Operand Address Byte.....	136
7.1.2	Modifier Field.....	136
7.1.3	Auxiliary Field.....	137
7.1.4	r/m Field.....	137
7.1.5	Displacement	137
7.1.6	Immediate Bytes	137
7.1.7	Segment Override Prefix	137
7.1.8	Segment Register	138
7.2	Explanation of Notation Used in Instruction Set Summary Table.....	138
7.2.1	Opcode.....	139
7.2.2	Flags Affected After Instruction.....	139
8.	Innovasic/AMD Part Number Cross-Reference Tables.....	140
9.	Errata.....	142
9.1	Errata Summary.....	142
9.2	Errata Detail	142
10.	Revision History	145
11.	For Additional Information.....	146

LIST OF FIGURES

Figure 1. IA186EM TQFP Package Diagram.....	16
Figure 2. IA188EM TQFP Package Diagram.....	19
Figure 3. TQFP Package Dimensions.....	22
Figure 4. IA186EM PQFP Package Diagram.....	23
Figure 5. IA188EM PQFP Package Diagram.....	26
Figure 6. PQFP Package Dimensions.....	29
Figure 7. Functional Block Diagram.....	44
Figure 8. Crystal Configuration.....	45
Figure 9. Organization of Clock.....	46
Figure 10. DMA Unit.....	54
Figure 11. Read Cycle.....	106
Figure 12. Multiple Read Cycles.....	107
Figure 13. Write Cycle.....	109
Figure 14. Multiple Write Cycles.....	110
Figure 15. PSRAM Read Cycle.....	112
Figure 16. PSRAM Write Cycle.....	114
Figure 17. PSRAM Refresh Cycle.....	116
Figure 18. Interrupt Acknowledge Cycle.....	117
Figure 19. Software Halt Cycle.....	119
Figure 20. Clock—Active Mode.....	120
Figure 21. Clock—Power-Save Mode.....	120
Figure 22. srdy—Synchronous Ready.....	121
Figure 23. ardy—Asynchronous Ready.....	122
Figure 24. Peripherals.....	122
Figure 25. Reset 1.....	123
Figure 26. Reset 2.....	123
Figure 27. Bus Hold Entering.....	124
Figure 28. Bus Hold Leaving.....	124
Figure 29. Synchronous Serial Interface.....	125

LIST OF TABLES

Table 1. IA186EM TQFP Numeric Pin Listing.....	17
Table 2. IA186EM TQFP Alphabetic Pin Listing.....	18
Table 3. IA188EM TQFP Numeric Pin Listing.....	20
Table 4. IA188EM TQFP Alphabetic Pin Listing.....	21
Table 5. IA186EM PQFP Numeric Pin Listing.....	24
Table 6. IA186EM PQFP Alphabetic Pin Listing.....	25
Table 7. IA188EM PQFP Numeric Pin Listing.....	27
Table 8. IA188EM PQFP Alphabetic Pin Listing.....	28
Table 9. Bus Cycle Types for bhe_n and ad0.....	31
Table 10. Bus Cycle Types for s2_n, s1_n, and s0_n.....	38
Table 11. IA186EM and IA188EM Absolute Maximum Ratings.....	42
Table 12. IA186EM and IA188EM Thermal Characteristics.....	42
Table 13. DC Characteristics Over Commercial Operating Ranges.....	42
Table 14. Interrupt Types.....	51
Table 15. Default Status of PIO Pins at Reset.....	56
Table 16. Peripheral Control Registers.....	58
Table 17. Peripheral Control Block Relocation Register.....	59
Table 18. Reset Configuration Register.....	59
Table 19. Processor Release Level Register.....	60
Table 20. Power-Save Control Register.....	60
Table 21. Enable Dynamic RAM Refresh Control Register.....	61
Table 22. Count for Dynamic RAM Refresh Control Register.....	62
Table 23. Memory Partition for Dynamic RAM Refresh Control Register.....	62
Table 24. DMA Control Registers.....	62
Table 25. DMA Transfer Count Registers.....	64
Table 26. DMA Destination Address High Register.....	65
Table 27. DMA Destination Address Low Register.....	65
Table 28. DMA Source Address High Register.....	65
Table 29. DMA Source Address Low Register.....	66
Table 30. MCS and PCS Auxiliary Register.....	66
Table 31. Midrange Memory Chip Select Register.....	68
Table 32. Peripheral Chip Select Register.....	69
Table 33. Low-Memory Chip Select Register.....	70
Table 34. Upper-Memory Chip Select Register.....	72
Table 35. Baud Rates.....	73
Table 36. Serial Port Baud Rate Divisor Registers.....	73
Table 37. Serial Port Receive Data Register.....	74
Table 38. Serial Port Transmit Data Register.....	74
Table 39. Serial Port Status Register.....	74
Table 40. Serial Port Control Register.....	75
Table 41. PIO Pin Assignments.....	77

Table 42. PDATA 0	78
Table 43. PDATA 1	78
Table 44. PIO Mode and PIO Direction Settings	79
Table 45. PDIR0	79
Table 46. PDIR1	79
Table 47. PIOMODE0	79
Table 48. PMODE1	80
Table 49. Timer 0 and Timer 1 Mode and Control Registers	80
Table 50. Timer 2 Mode and Control Registers	81
Table 51. Timer Maxcount Compare Registers	82
Table 52. Timer Count Registers	83
Table 53. Serial Port Interrupt Control Registers	83
Table 54. Watchdog Timer Interrupt Control Register	84
Table 55. INT4 Control Register	84
Table 56. INT2/INT3 Control Register	85
Table 57. INT0/INT1 Control Register	86
Table 58. Timer Control Unit Interrupt Control Register	86
Table 59. Timer Interrupt Control Register	87
Table 60. DMA and Interrupt Control Register (Master Mode)	87
Table 61. DMA and Interrupt Control Register (Slave Mode)	88
Table 62. Interrupt Status Register (Master Mode)	88
Table 63. Interrupt Status Register (Slave Mode)	89
Table 64. Interrupt Request Register (Master Mode)	89
Table 65. Interrupt Request Register (Slave Mode)	90
Table 66. In-Service Register (Master Mode)	91
Table 67. In-Service Register (Slave Mode)	91
Table 68. Priority Mask Register	92
Table 69. Interrupt MASK Register (Master Mode)	93
Table 70. Interrupt MASK Register (Slave Mode)	93
Table 71. POLL Status Register	94
Table 72. Poll Register	95
Table 73. End-of-Interrupt Register	95
Table 74. Specific End-of-Interrupt Register	95
Table 75. Interrupt Vector Register	96
Table 76. Synchronous Serial Receive Register	96
Table 77. Synchronous Serial Transmit Registers	97
Table 78. Synchronous Serial Control Registers	97
Table 79. Synchronous Serial Status Registers	98
Table 80. AC Characteristics Over Commercial Operating Ranges (40 MHz)	99
Table 81. Alphabetic Key to Waveform Parameters	102
Table 82. Numeric Key to Waveform Parameters	104
Table 83. Read Cycle Timing	108
Table 84. Write Cycle Timing	111

Table 85. PSRAM Read Cycle Timing.....	113
Table 86. PSRAM Write Cycle Timing.....	115
Table 87. PSRAM Refresh Cycle	116
Table 88. Interrupt Acknowledge Cycle Timing	118
Table 89. Software Halt Cycle Timing	119
Table 90. Clock Timing	121
Table 91. Ready and Peripheral Timing	123
Table 92. Reset and Bus Hold Timing.....	125
Table 93. Synchronous Serial Interface Timing	126
Table 94. Instruction Set Summary	126
Table 95. Innovasic/AMD Part Number Cross-Reference for the TQFP	140
Table 96. Innovasic/AMD Part Number Cross-Reference for the PQFP	141
Table 97. Summary of Errata.....	142
Table 98. Revision History	145

CONVENTIONS

Arial Bold Designates headings, figure captions, and table captions.

Blue Designates hyperlinks (PDF copy only).

Italics Designates emphasis or caution related to nearby information. Italics is also used to designate variables, refer to related documents, and to differentiate terms from other common words (e.g., “During refresh cycles, the *a* and *ad* busses may not have the same address during the address phase of the *ad* bus cycle.” “The *hold* latency time [time between the *hold* and *hlda*] depends on the current processor activity when the hold is received.”).

ACRONYMS AND ABBREVIATIONS

AMD	Advanced Micro Devices
BIC	Bus Interface and Control
CDRAM	Count for Dynamic RAM
CSC	Chip Selects and Control
DA	Disable Address
DMA	Direct Memory Access
EOI	End of Interrupt
ISR	Interrupt Service Routine
LMCS	Low-Memory Chip Select
MC	Maximum Count
MDRAM	Memory Partition for Dynamic RAM
MILES™	Managed IC Lifetime Extension System
MMCS	Midrange Memory Chip Select
NMI	nonmaskable interrupt
PCB	peripheral control block
PIO	programmable I/O
PLL	phase-lock-loop
POR	power-on reset
PQFP	Plastic Quad Flat Package
PSRAM	Pseudo-Static RAM
RCU	Refresh Control Unit
RoHS	Restriction of Hazardous Substances
SFNM	Special Fully Nested mode
TQFP	Thin Quad Flat Package
UART	Universal Asynchronous Receiver-Transmitter
UMCS	Upper Memory Chip Select

1. Introduction

The IA186EM/IA188EM is a form, fit, and function replacement for the original Advanced Micro Devices Am186EM/Am188EM family of microcontrollers. Innovasic produces replacement ICs using its MILES™, or Managed IC Lifetime Extension System cloning technology. This technology produces replacement ICs far more complex than “emulation” while ensuring they are compatible with the original IC. MILES™ captures the design of a clone so it can be produced even as silicon technology advances. MILES™ also verifies the clone against the original IC so that even the “undocumented features” are duplicated.

1.1 General Description

The IA186EM/IA188EM family of microcontrollers replaces obsolete Am186EM/188EM devices, allowing customers to retain existing board designs, software compilers/assemblers and emulation tools, thereby avoiding expensive redesign efforts.

The IA186EM/IA188EM microcontrollers are an upgrade for the 80C186/80C 188 microcontroller designs, with integrated peripherals to provide increased functionality and reduce system costs. The Innovasic devices are created to satisfy requirements of embedded products designed for telecommunications, office automation and storage, and industrial controls.

1.2 Features

- Pin-for-pin compatible with Am186EM/Am188EM devices
- All features are retained, including:
 - A phase-lock loop (PLL) allowing same crystal/system clock frequency
 - 8086/8088 instruction set with additional 186 instruction set extensions
 - Programmable interrupt controller
 - Two Direct Memory Access (DMA) channels
 - Three 16-bit timers
 - Programmable chip select logic and wait-state generator
 - Dedicated watchdog timer
 - Two independent asynchronous serial ports (UARTs)
 - DMA capability
 - Hardware flow control
 - 7-, 8-, or 9-bit data capability
- Pulse Width Demodulator feature
- Up to 32 programmable I/O pins (PIO)
- Pseudo-static/dynamic RAM controller
- Fully static CMOS design
- 40-MHz operation at industrial operating conditions
- +5 VDC power supply

2. Packaging , Pin Descriptions, and Physical Dimensions

Information on the packages and pin descriptions for the IA186EM and the IA188EM is provided separately. Refer to sections, figures, and tables for information on the device of interest.

2.1 Packages and Pinouts

The Innovasic Semiconductor IA186EM and IA188EM microcontroller is available in the following packages:

- 100-Pin Thin Quad Flat Package (TQFP), equivalent to original SQFP package
- 100-Plastic Quad Flat Package (PQFP), equivalent to original PQFP package

2.1.1 IA186EM TQFP Package

The pinout for the IA186EM TQFP package is as shown in Figure 1. The corresponding pinout is provided in Tables 1 and 2.

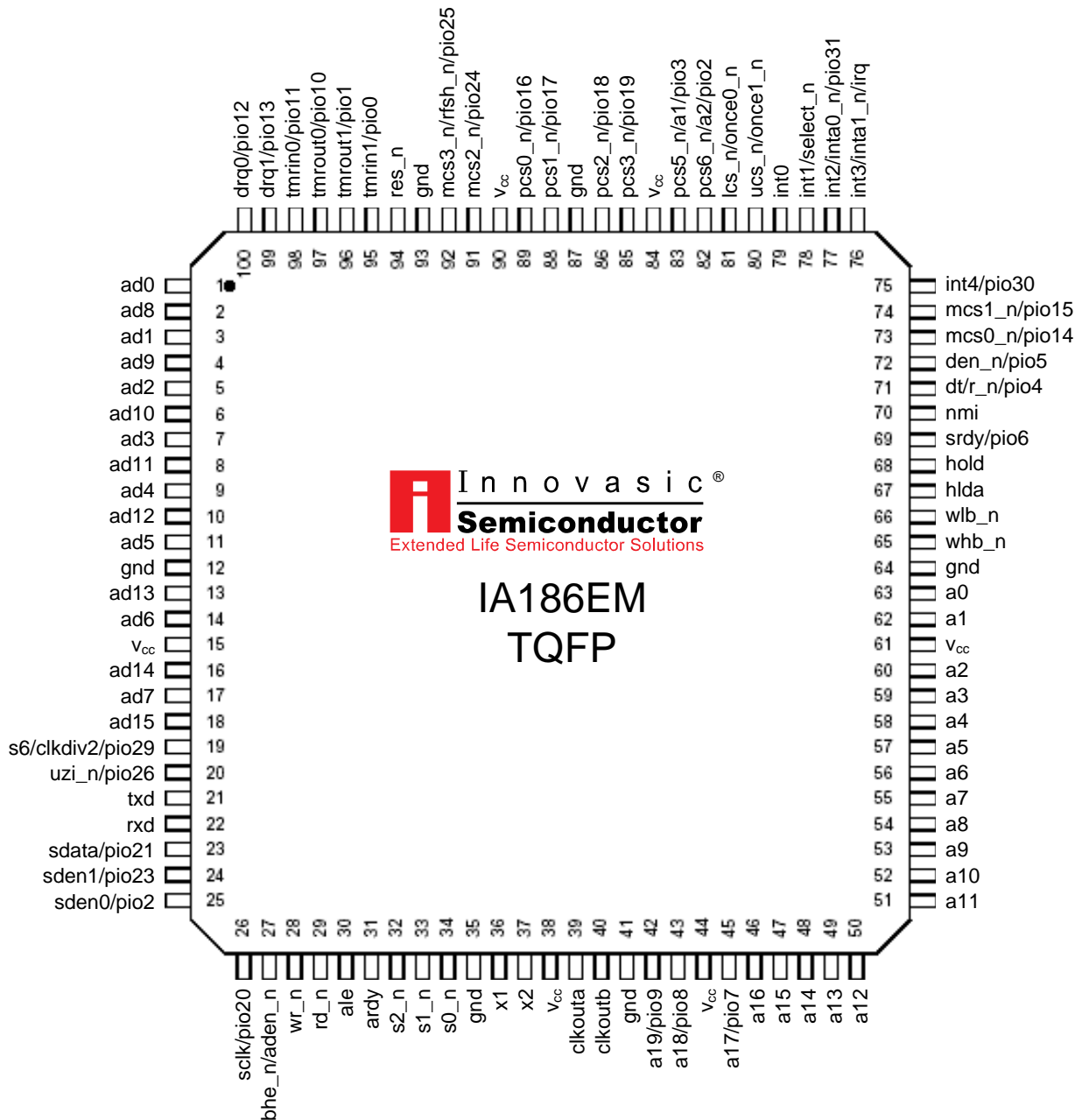

Figure 1. IA186EM TQFP Package Diagram

Table 1. IA186EM TQFP Numeric Pin Listing

Pin	Name
1	ad0
2	ad8
3	ad1
4	ad9
5	ad2
6	ad10
7	ad3
8	ad11
9	ad4
10	ad12
11	ad5
12	gnd
13	ad13
14	ad6
15	v _{cc}
16	ad14
17	ad7
18	ad15
19	s6/clkdiv2/pio29
20	uzi_n/pio26
21	txd
22	rxid
23	sdata/pio21
24	sden1/pio23
25	sden0/pio22
26	sclk/pio20
27	bhe_n/aden_n
28	wr_n
29	rd_n
30	ale
31	ardy
32	s2_n
33	s1_n
34	s0_n

Pin	Name
35	gnd
36	x1
37	x2
38	v _{cc}
39	clkouta
40	clkoutb
41	gnd
42	a19/pio9
43	a18/pio8
44	v _{cc}
45	a17/pio7
46	a16
47	a15
48	a14
49	a13
50	a12
51	a11
52	a10
53	a9
54	a8
55	a7
56	a6
57	a5
58	a4
59	a3
60	a2
61	v _{cc}
62	a1
63	a0
64	gnd
65	whb_n
66	wlb_n
67	hlda

Pin	Name
68	hold
69	srdy/pio6
70	nmi
71	dt/r_n/pio4
72	den_n/pio5
73	mcs0_n/pio14
74	mcs1_n/pio15
75	int4/pio30
76	int3/inta1_n/irq
77	int2/inta0_n/pio31
78	int1/select_n
79	int0
80	ucs_n/once1_n
81	lcs_n/once0_n
82	pcs6_n/a2/pio2
83	pcs5_n/a1/pio3
84	v _{cc}
85	pcs3_n/pio19
86	pcs2_n/pio18
87	gnd
88	pcs1_n/pio17
89	pcs0_n/pio16
90	v _{cc}
91	mcs2_n/pio24
92	mcs3_n/rfsh_n/pio25
93	gnd
94	res_n
95	tmrin1/pio0
96	tmrout1/pio1
97	tmrout0/pio10
98	tmrin0/pio11
99	drq1/pio13
100	drq0/pio12

Table 2. IA186EM TQFP Alphabetic Pin Listing

Name	Pin	Name	Pin	Name	Pin
a0	63	ad14	16	pcs3_n/pio19	85
a1	62	ad15	18	pcs5_n/a1/pio3	83
a2	60	ale	30	pcs6_n/a2/pio2	82
a3	59	ardy	30	rd_n	29
a4	58	bhe_n/aden_n	27	res_n	94
a5	57	clkouta	39	rxd/pio23	24
a6	56	clkoutb	40	s0_n	34
a7	55	den_n/pio5	72	s1_n	33
a8	54	drq0/pio12	100	s2_n	32
a9	53	drq1/pio13	99	s6/clkdiv2/pio29	19
a10	52	dt/r_n/pio4	71	sclk/pio20	26
a11	51	gnd	12	sdata/pio21	23
a12	50	gnd	36	sden0/pio22	25
a13	49	gnd	41	sden1/pio23	24
a14	48	gnd	64	srdy/pio6	69
a15	47	gnd	87	tmrin0/pio11	98
a16	46	gnd	93	tmrin1/pio0	95
a17/pio7	45	hllda	67	tmrout0/pio10	97
a18/pio8	43	hold	68	tmrout1/pio1	96
a19/pio9	42	int0	79	txd/pio27	21
ad0	1	int1/select_n	78	ucs_n/once1_n	80
ad1	3	int2/inta0_n/pio31	77	uzi_n/pio26	20
ad2	5	int3/inta1_n/irq	76	V _{CC}	15
ad3	7	int4/pio30	75	V _{CC}	38
ad4	9	lcs_n/once0_n	81	V _{CC}	44
ad5	11	mcs0_n/pio14	73	V _{CC}	61
ad6	14	mcs1_n/pio15	74	V _{CC}	84
ad7	17	mcs2_n/pio24	91	V _{CC}	90
ad8	2	mcs3_n/rfsh_n/pio25	92	whb_n	65
ad9	4	nmi	70	wlb_n	66
ad10	6	pcs0_n/pio16	89	wr_n	28
ad11	8	pcs1_npio	88	x1	36
ad12	10	pcs2_n/pio18	86	x2	37
ad13	13				

2.1.2 IA188EM TQFP Package

The pinout for the IA188EM TQFP package is as shown in Figure 2. The corresponding pinout is provided in Tables 3 and 4.

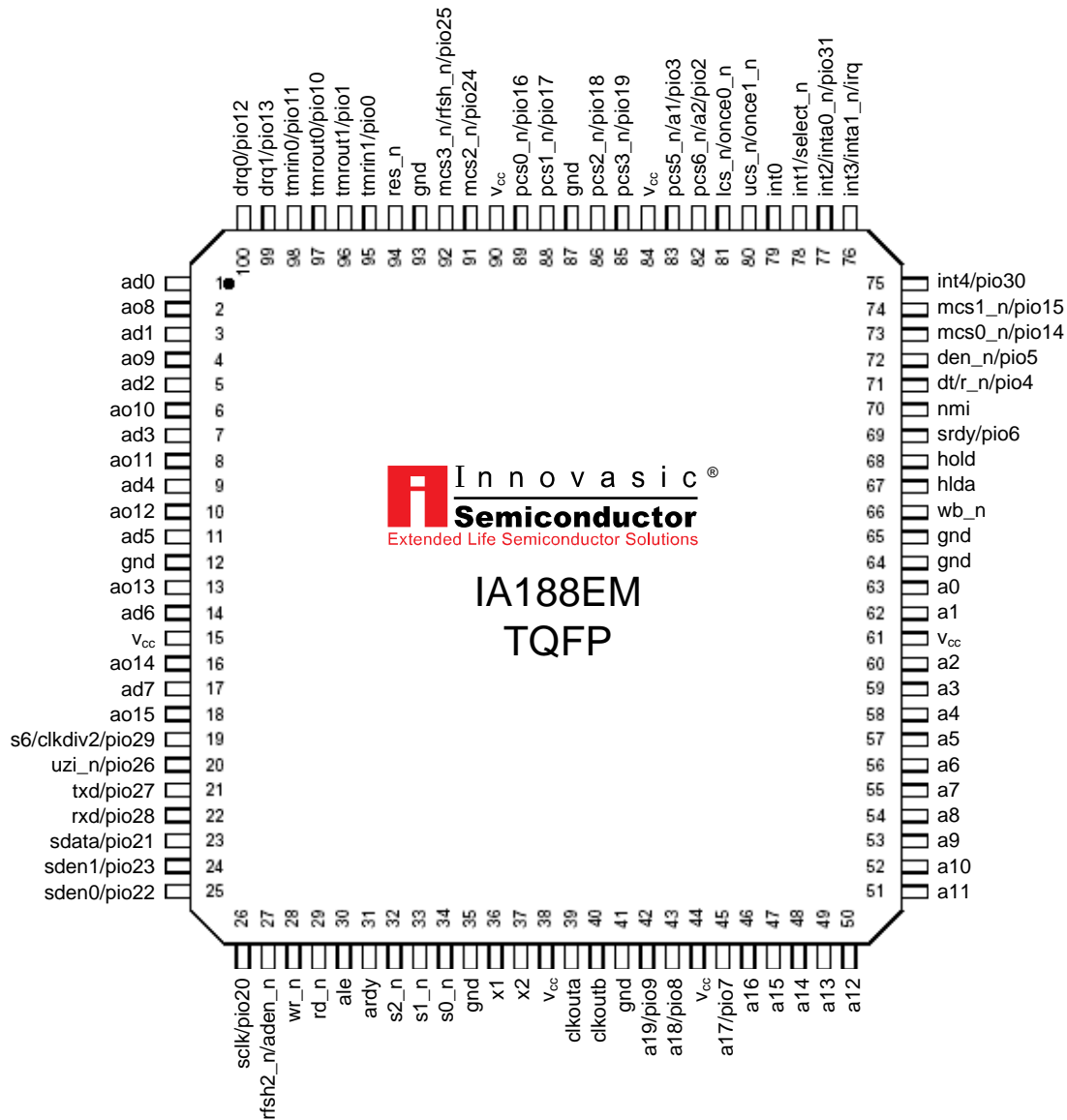

Figure 2. IA188EM TQFP Package Diagram

Table 3. IA188EM TQFP Numeric Pin Listing

Pin	Name
1	ad0
2	ao8
3	ad1
4	ao9
5	ad2
6	ao10
7	ad3
8	ao11
9	ad4
10	ao12
11	ad5
12	gnd
13	ao13
14	ad6
15	v _{cc}
16	ao14
17	ad7
18	ao15
19	s6/clkdiv2/pio29
20	uzi_n/pio26
21	txd/pio27
22	rx/pio28
23	sdata/pio21
24	sden1/pio23
25	sden0/pio22
26	sclk/pio20
27	rfsh2_n/aden_n
28	wr_n
29	rd_n
30	ale
31	ardy
32	s2_n
33	s1_n
34	s0_n

Pin	Name
35	gnd
36	x1
37	x2
38	v _{cc}
39	clkouta
40	clkoutb
41	gnd
42	a19/pio9
43	a18/pio8
44	v _{cc}
45	a17/pio7
46	a16
47	a15
48	a14
49	a13
50	a12
51	a11
52	a10
53	a9
54	a8
55	a7
56	a6
57	a5
58	a4
59	a3
60	a2
61	v _{cc}
62	a1
63	a0
64	gnd
65	gnd
66	wb_n
67	hlda

Pin	Name
68	hold
69	srdy/pio6
70	nmi
71	dt/r_n/pio4
72	den_n/pio5
73	mcs0_n/pio14
74	mcs1_n/pio15
75	int4/pio30
76	int3/inta1_n/irq
77	int2/inta0_n/pio31
78	int1/select_n
79	int0
80	ucs_n/once1_n
81	lcs_n/once0_n
82	pcs6_n/a2/pio2
83	pcs5_n/a1/pio3
84	v _{cc}
85	pcs3_n/pio19
86	pcs2_n/pio18
87	gnd
88	pcs1_n/pio17
89	pcs0_n/pio16
90	v _{cc}
91	mcs2_n/pio24
92	mcs3_n/rfsh_n/pio25
93	gnd
94	res_n
95	tmrin1/pio0
96	tmrout1/pio1
97	tmrout0/pio10
98	tmrin0/pio11
99	drq1/pio13
100	drq0/pio12

Table 4. IA188EM TQFP Alphabetic Pin Listing

Name	Pin	Name	Pin	Name	Pin
a0	63	ao13	13	pcs3_n/pio19	85
a1	62	ao14	16	pcs5_n/a1/pio3	83
a2	60	ao15	18	pcs6_n/a2/pio2	82
a3	59	ardy	30	rd_n	29
a4	58	clkouta	39	res_n	94
a5	57	clkoutb	40	rfsh2_n/aden_n	27
a6	56	den_n/pio5	72	rxd/pio28	22
a7	55	drq0/pio12	100	s0_n	34
a8	54	drq1/pio13	99	s1_n	33
a9	53	dt/r_n/pio4	71	s2_n	32
a10	52	gnd	12	s6/lock_n/clkdiv2/pio29	19
a11	51	gnd	35	sclk/pio20	26
a12	50	gnd	41	sdata/pio21	23
a13	49	gnd	64	sden0/pio22	25
a14	48	gnd	65	sden1/pio23	24
a15	47	gnd	87	srdy/pio6	69
a16	46	gnd	93	tmrin0/pio11	98
a17/pio7	45	hlda	67	tmrin1/pio0	95
a18/pio8	43	hold	68	tmrout0/pio10	97
a19/pio9	42	int0	79	tmrout1/pio1	96
ale	30	int1/select_n	78	txd/pio27	21
ad0	1	int2/inta0_n/pio31	77	ucs_n/once1_n	80
ad1	3	int3/inta1_n/irq	76	uzi_n/pio26	20
ad2	5	int4/pio30	75	V _{CC}	15
ad3	7	lcs_n/once0_n	81	V _{CC}	38
ad4	9	mcs0_n/pio14	73	V _{CC}	44
ad5	11	mcs1_n/pio15	74	V _{CC}	61
ad6	14	mcs2_n/pio24	91	V _{CC}	84
ad7	17	mcs3_n/rfsh_n/pio25	92	V _{CC}	90
ao8	2	nmi	70	wb_n	66
ao9	4	pcs0_n/pio16	89	wr_n	28
ao10	6	pcs1_n/pio17	88	x1	36
ao11	8	pcs2_n/pio18	86	x2	37
ao12	10				

2.1.3 TQFP Physical Dimensions

The physical dimensions for the TQFP are as shown in Figure 3.

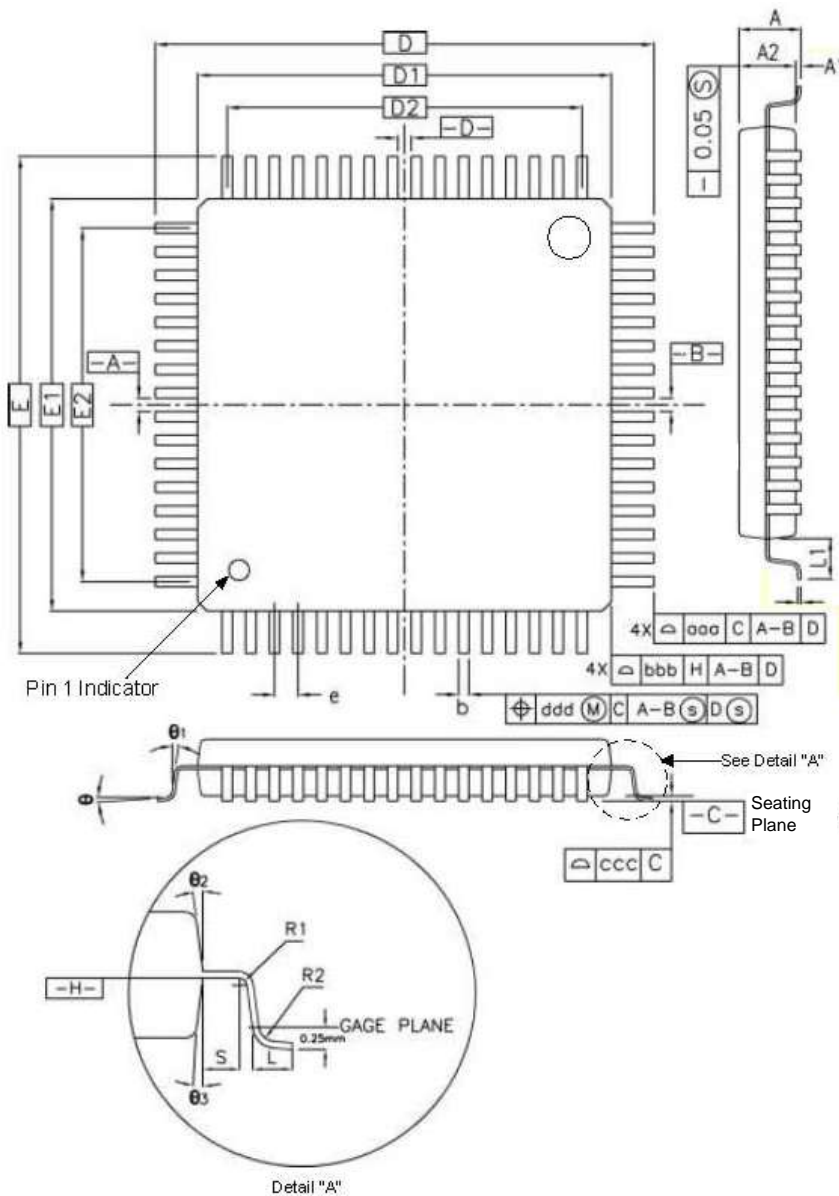

Legend:

Symbol	Millimeter			Inch		
	Min	Nom	Max	Min	Nom	Max
A	-	-	1.20	-	-	0.047
A1	0.05	-	0.15	0.002	-	0.006
A2	0.95	1.00	1.05	0.037	0.039	0.041
b	0.17	0.20	0.27	0.007	0.008	0.011
c	0.09	-	0.20	0.004	-	0.008
D	16.00 BSC.			0.630 BSC.		
D1	14.00 BSC.			0.551 BSC.		
D2	12.00			0.472		
e	0.50 BSC.			0.02 BSC.		
E	16.00 BSC.			0.630 BSC.		
E1	14.00 BSC.			0.551 BSC.		
E2	12.00			0.472		
L	0.45	0.60	0.75	0.018	0.024	0.030
L1	1.00 REF			0.039 REF		
R1	0.08	-	-	0.003	-	-
R2	0.08	-	0.20	0.003	-	0.008
S	0.20			0.008		
θ	0°	3.5°	7°	0°	3.5°	7°
θ ₁	0°			0°		
θ ₂	11°	12°	13°	11°	12°	13°
θ ₃	11°	12°	13°	11°	12°	13°
Tolerances of Form and Position						
aaa	0.20			0.008		
bbb	0.20			0.008		
ccc	0.08			0.003		
ddd	0.08			0.003		

Note:

Control dimensions are in millimeters.

Figure 3. TQFP Package Dimensions

2.1.4 IA186EM PQFP Package

The pinout for the IA186EM PQFP package is as shown in Figure 4. The corresponding pinout is provided in Tables 5 and 6.

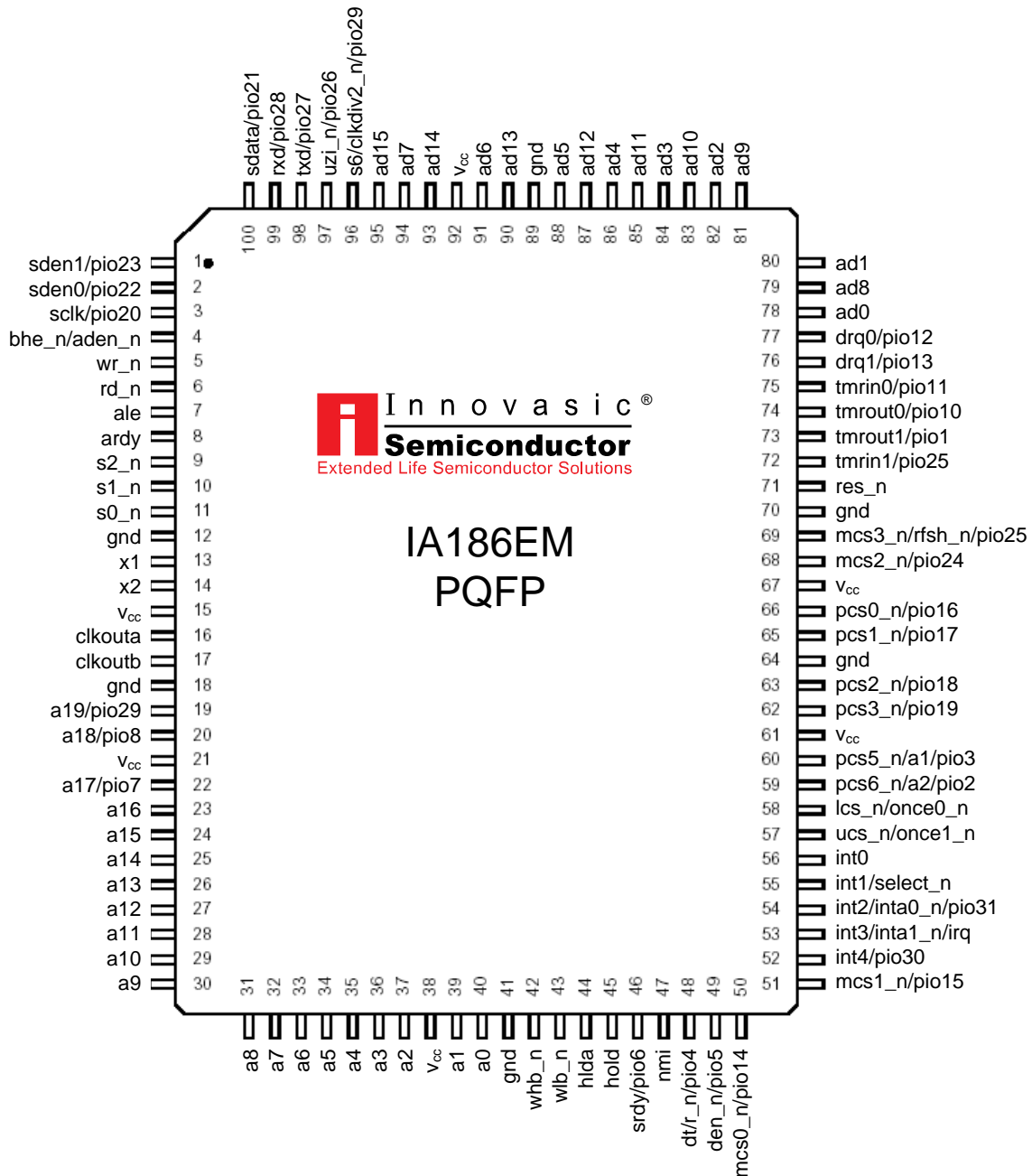

Figure 4. IA186EM PQFP Package Diagram

Table 5. IA186EM PQFP Numeric Pin Listing

Pin	Name	Pin	Name	Pin	Name
1	sden1/pio23	35	a4	68	mcs2_n/pio24
2	sden0/pio22	36	a3	69	mcs3_n/rfsh_n/pio25
3	sclk/pio20	37	a2	70	gnd
4	bhe_n/aden_n	38	v _{cc}	71	res_n
5	wr_n	39	a1	72	tmrin1/pio25
6	rd_n	40	a0	73	tmrout1/pio1
7	ale	41	gnd	74	tmrout0/pio10
8	ardy	42	whb_n	75	tmrin0/pio11
9	s2_n	43	wlb_n	76	drq1/pio13
10	s1_n	44	hlda	77	drq0/pio12
11	s0_n	45	hold	78	ad0
12	gnd	46	srady/pio6	79	ad8
13	x1	47	nmi	80	ad1
14	x2	48	dt/r_n/pio4	81	ad9
15	v _{cc}	49	den_n/pio5	82	ad2
16	clkouta	50	mcs0_n/pio14	83	ad10
17	clkoutb	51	mcs1_n/pio15	84	ad3
18	gnd	52	int4/pio30	85	ad11
19	a19/pio29	53	int3/inta1_n/irq	86	ad4
20	a18/pio8	54	int2/inta0_n/pio31	87	ad12
21	v _{cc}	55	int1/select_n	88	ad5
22	a17/pio7	56	int0	89	gnd
23	a16	57	ucs_n/once1_n	90	ad13
24	a15	58	lcs_n/once0_n	91	ad6
25	a14	59	pcs6_n/a2/pio2	92	v _{cc}
26	a13	60	pcs5_n/a1/pio3	93	ad14
27	a12	61	v _{cc}	94	ad7
28	a11	62	pcs3_n/pio19	95	ad15
29	a10	63	pcs2_n/pio18	96	s6/clkdiv2_n/pio29
30	a9	64	gnd	97	uzi_n/pio26
31	a8	65	pcs1_n/pio17	98	txd/pio27
32	a7	66	pcs0_n/pio16	99	rxn/pio28
33	a6	67	v _{cc}	100	sdata/pio21
34	a5				

Table 6. IA186EM PQFP Alphabetic Pin Listing

Name	Pin	Name	Pin	Name	Pin
a0	40	ad14	93	pcs3_n/pio19	62
a1	39	ad15	95	pcs5_n/a1/pio3	60
a2	37	ale	7	pcs6_n/a2/pio2	59
a3	36	ardy	8	rd_n	6
a4	35	bhe_n/aden_n	4	res_n	71
a5	34	clkouta	16	rxd/pio28	99
a6	33	clkoutb	17	s0_n	11
a7	32	den_n/pio5	49	s1_n	10
a8	31	drq0/pio12	77	s2_n	9
a9	30	drq1/pio13	76	s6/clkdir2/pio29	96
a10	29	dt/r_n/pio4	48	sclk/pio20	3
a11	28	gnd	12	sdata/pio21	100
a12	27	gnd	18	sden0/pio22	2
a13	26	gnd	41	sden1/pio23	1
a14	25	gnd	64	srdy/pio6	46
a15	24	gnd	70	tmrin0/pio11	75
a16	23	gnd	89	tmrin1/pio0	72
a17/pio7	22	hllda	44	tmrout0/pio10	74
a18/pio8	20	hold	45	tmrout1/pio1	73
a19/pio9	19	int0	56	txd/pio27	98
ad0	78	int1/select_n	55	ucs_n/once1_n	57
ad1	80	int2/inta0_n/pio31	54	uzi_n/pio26	97
ad2	82	int3/inta1_n/irq	53	V _{CC}	15
ad3	84	int4/pio30	52	V _{CC}	21
ad4	86	lcs_n/once0_n	58	V _{CC}	38
ad5	88	mcs0_n/pio14	50	V _{CC}	61
ad6	91	mcs1_n/pio15	51	V _{CC}	67
ad7	94	mcs2_n/pio24	68	V _{CC}	92
ad8	79	mcs3_n/rfsh_n/pio25	69	whb_n	42
ad9	81	nmi	47	wlb_n	43
ad10	83	pcs0_n/pio16	66	wr_n	5
ad11	85	pcs1_n/pio17	65	x1	13
ad12	87	pcs2_n/pio18	63	x2	14
ad13	90				

2.1.5 IA188EM PQFP Package

The pinout for the IA188EM PQFP package is as shown in Figure 5. The corresponding pinout is provided in Tables 7 and 8.

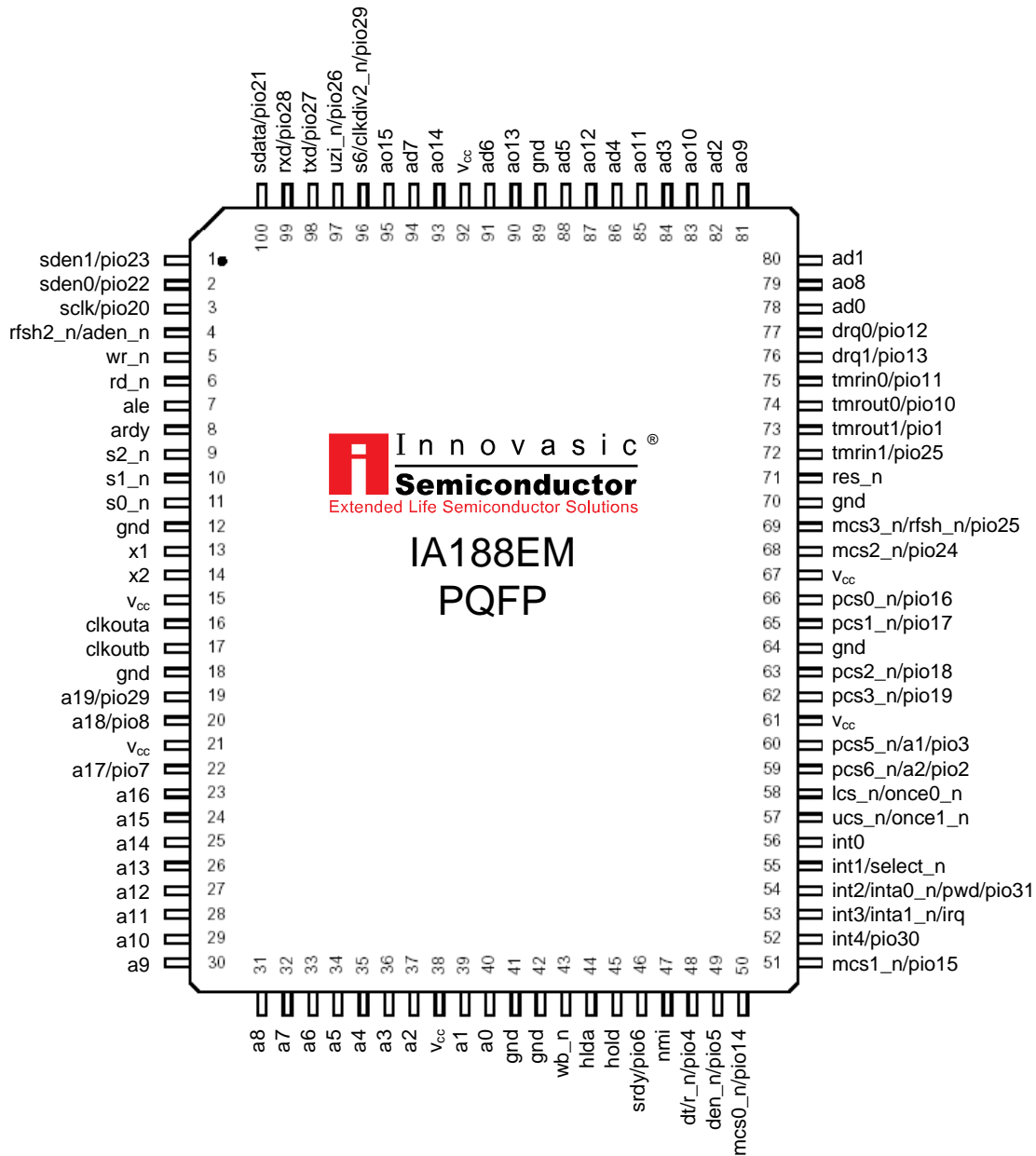

Figure 5. IA188EM PQFP Package Diagram

Table 7. IA188EM PQFP Numeric Pin Listing

Pin	Name
1	sden1/pio23
2	sden0/pio22
3	sclk/pio20
4	rfsh2_n/aden_n
5	wr_n
6	rd_n
7	ale
8	ardy
9	s2_n
10	s1_n
11	s0_n
12	gnd
13	x1
14	x2
15	v _{cc}
16	clkouta
17	clkoutb
18	gnd
19	a19/pio29
20	a18/pio8
21	v _{cc}
22	a17/pio7
23	a16
24	a15
25	a14
26	a13
27	a12
28	a11
29	a10
30	a9
31	a8
32	a7
33	a6
34	a5

Pin	Name
35	a4
36	a3
37	a2
38	v _{cc}
39	a1
40	a0
41	gnd
42	gnd
43	wb_n
44	hlda
45	hold
46	srady/pio6
47	nmi
48	dt/r_n/pio4
49	den_n/pio5
50	mcs0_n/pio14
51	mcs1_n/pio15
52	int4/pio30
53	int3/inta1_n/irq
54	int2/inta0_n/pwd/pio31
55	int1/select_n
56	int0
57	ucs_n/once1_n
58	lcs_n/once0_n
59	pcs6_n/a2/pio2
60	pcs5_n/a1/pio3
61	v _{cc}
62	pcs3_n/pio19
63	pcs2_n/pio18
64	gnd
65	pcs1_n/pio17
66	pcs0_n/pio16
67	v _{cc}

Pin	Name
68	mcs2_n/pio24
69	mcs3_n/rfsh_n/pio25
70	gnd
71	res_n
72	tmrin1/pio25
73	tmrout1/pio1
74	tmrout0/pio10
75	tmrin0/pio11
76	drq1/pio13
77	drq0/pio12
78	ad0
79	ao8
80	ad1
81	ao9
82	ad2
83	ao10
84	ad3
85	ao11
86	ad4
87	ao12
88	ad5
89	gnd
90	ao13
91	ad6
92	v _{cc}
93	ao14
94	ad7
95	ao15
96	s6/clkdiv2_n/pio29
97	uzi_n/pio26
98	txd/pio27
99	rxid/pio28
100	sdata/pio21

Table 8. IA188EM PQFP Alphabetic Pin Listing

Name	Pin	Name	Pin	Name	Pin
a0	40	ao13	90	pcs3_n/rts1_n/rtr1_n/pio19	62
a1	39	ao14	93	pcs5_n/a1/pio3	60
a2	37	ao15	95	pcs6_n/a2/pio2	59
a3	36	ardy	8	rd_n	6
a4	35	clkouta	16	res_n	71
a5	34	clkoutb	17	rfsh2_n/aden_n	4
a6	33	den_n/ds_n/pio5	49	rx/pio28	99
a7	32	drq0/pio12	77	s0_n	11
a8	31	drq1/pio13	76	s1_n	10
a9	30	dt/r_n/pio4	48	s2_n	9
a10	29	gnd	12	s6/lock_n/clkdir2/pio29	96
a11	28	gnd	18	sclk/pio20	3
a12	27	gnd	41	sdata/pio21	100
a13	26	gnd	42	sden0/pio22	2
a14	25	gnd	64	sden1/pio23	1
a15	24	gnd	70	sr/pio6	46
a16	23	gnd	89	tmrin0/pio11	75
a17/pio7	22	hlida	44	tmrin1/pio0	72
a18/pio8	20	hold	45	tmrout0/pio10	74
a19/pio9	19	int0	56	tmrout1/pio1	73
ad0	78	int1/select_n	55	txd/pio27	98
ad1	80	int2/inta0_n/pwd/pio31	54	ucs_n/once1_n	57
ad2	82	int3/inta1_n/irq	53	uzi_n/pio26	97
ad3	84	int4/pio30	52	V _{CC}	15
ad4	86	lcs_n/once0_n	58	V _{CC}	21
ad5	88	mcs0_n/pio14	50	V _{CC}	38
ad6	91	mcs1_n/pio15	51	V _{CC}	61
ad7	94	mcs2_n/pio24	68	V _{CC}	67
ale	7	mcs3_n/rfsh_n/pio25	69	V _{CC}	92
ao8	79	nmi	47	wb_n	42
ao9	81	pcs0_n/pio16	66	wr_n	5
ao10	83	pcs1_n/pio17	65	x1	13
ao11	85	pcs2_n/cts1_n/enrx1_n/pio18	63	x2	14
ao12	87				

2.1.6 PQFP Physical Dimensions

The physical dimensions for the PQFP are as shown in Figure 6.

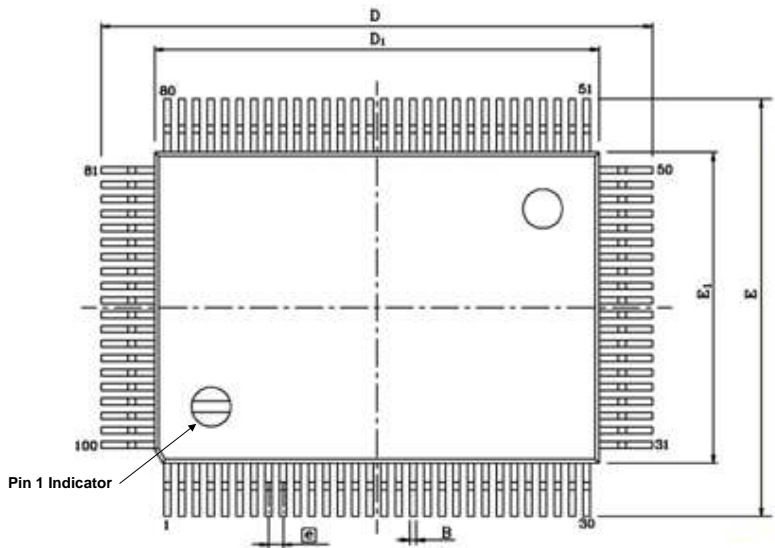

Legend						
Symbol	Millimeter			Inch		
	Min	Nom	Max	Min	Nom	Max
A	–	–	3.40	–	–	0.134
A ₁	0.25	–	–	0.010	–	–
A ₂	2.73	2.85	2.97	0.107	0.112	0.117
B	0.25	0.30	0.38	0.010	0.012	0.015
B ₁	0.22	0.30	0.33	0.009	0.012	0.013
C	0.13	0.15	0.23	0.005	0.006	0.009
C ₁	0.11	0.15	0.17	0.004	0.006	0.007
D	23.00	23.20	23.40	0.906	0.913	0.921
D ₁	19.90	20.00	20.10	0.783	0.787	0.791
E	17.00	17.20	17.40	0.669	0.677	0.685
E ₁	13.90	14.00	14.10	0.547	0.551	0.555
e	0.65 BSC.			0.026 BSC.		
L	0.73	0.88	1.03	0.029	0.035	0.041
L ₁	1.60 BSC.			0.063 BSC.		
R ₁	0.13	–	–	0.005	–	–
R ₂	0.13	–	0.30	0.005	–	0.012
S	0.20	–	–	0.008	–	–
Y	–	–	0.10	–	–	0.004
θ	0°	–	7°	0°	–	7°
θ ₁	0°	–	–	0°	–	–
θ ₂	9°	10°	11°	9°	10°	11°
θ ₃	9°	10°	11°	9°	10°	11°

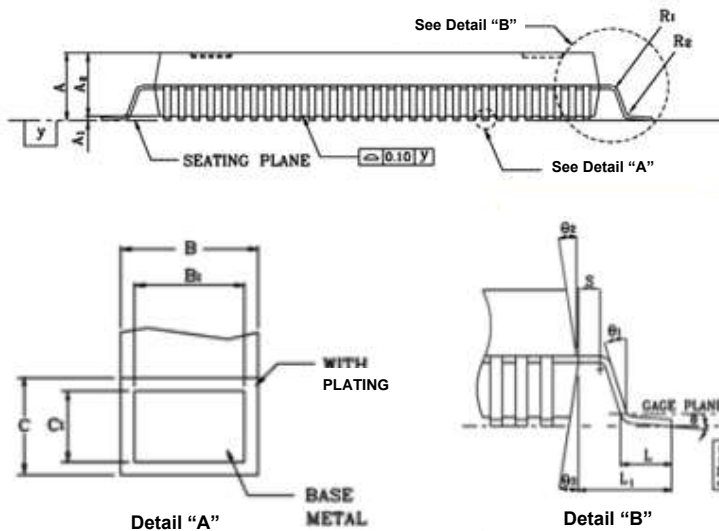

Notes:

1. Dimensions D₁ and E₁ do not include mold protrusion, but mold mismatch is included. Allowable protrusion is 0.25mm/0.010" per side.
2. Dimension B does not include Dambar protrusion. Allowable protrusion is 0.08mm/0.003" total in excess of the B dimension at maximum material condition. Dambar cannot be located on the lower radius or the foot.
3. Controlling dimension: millimeter.

Figure 6. PQFP Package Dimensions

2.2 Pin Descriptions

2.2.1 a19/pio9, a18/pio8, a17/pio7, a16–a0—Address Bus (synchronous outputs with tristate)

These pins are the system's source of non-multiplexed I/O or memory addresses and occur a half clkouta cycle before the multiplexed address/data bus (ad15–ad0 for the IA186EM or ao15–ao8 and ad7–ad0 for the IA188EM). The address bus is tristated during a bus hold or reset.

2.2.2 ad15–ad8 (IA186EM)—Address/data bus (level-sensitive synchronous inouts with tristate)

These pins are the system's source of time-multiplexed I/O or memory addresses and data. The address function of these pins can be disabled (see [bhe_n/aden_n pin description](#)). If the address function of these pins is enabled, the address will be present on this bus during t_1 of the bus cycle and data will be present during t_2 , t_3 , and t_4 of the same bus cycle.

If whb_n is not active, these pins are tristated during t_2 , t_3 , and t_4 of the bus cycle.

The address/data bus is tristated during a bus hold or reset.

These pins can be used to load the internal Reset Configuration register (RESCON, offset 0F6h) with configuration data during a power-on reset (POR).

2.2.3 ad7–ad0—Address/Data bus (level-sensitive synchronous inouts with tristate)

These pins are the system's source of time-multiplexed low-order byte of the addresses for I/O or memory and 8-bit data. The low-order address byte will be present on this bus during t_1 of the bus cycle and the 8-bit data will be present during t_2 , t_3 , and t_4 of the same bus cycle.

The address function of these pins can be disabled (see [bhe_n/aden_n pin description](#)).

If wlb_n (IA186EM) is not active, these pins are tristated during t_2 , t_3 , and t_4 of the bus cycle. The address/data bus is tristated during a bus hold or reset.

2.2.4 ao15–ao8 (IA188EM)—Address-only bus (level-sensitive synchronous outputs with tristate)

The address-only bus will contain valid high-order address bits during the bus cycle (t_1 , t_2 , t_3 , and t_4) if the bus is enabled.

These pins are combined with ad7–ad0 to complete the multiplexed address bus and are tristated during a bus hold or reset condition.

2.2.5 ale—Address Latch Enable (synchronous output)

This signal indicates the presence of an address on the address bus (ad15–ad0 for the IA186EM or ao15–ao8 and ad7–ad0 for the IA188EM), which is guaranteed to be valid on the falling edge of ale.

2.2.6 ardy—Asynchronous Ready (level-sensitive asynchronous input)

This asynchronous signal provides an indication to the microcontroller that the addressed I/O device or memory space will complete a data transfer. This active high signal is asynchronous with respect to clkouta and if the falling edge of ardy is not synchronized to clkouta, an additional clock cycle may be added

Signal ardy should be tied high to maintain a permanent assertion of the ready condition. On the other hand, if the ardy signal is not used by the system it should be tied low, which passes control to the srdy signal.

2.2.7 bhe_n/aden_n (IA186EM)—Bus High Enable (synchronous output with tristate)/Address Enable (input with internal pull-up)

The bhe_n and address bit ad0 or a0 inform the system which bytes of the data bus (upper, lower, or both) are involved in the current memory access bus cycle as shown Table 9.

Table 9. Bus Cycle Types for bhe_n and ad0

bhe_n	ad0	Type of Bus Cycle
0	0	Word Transfer
0	1	High-Byte Transfer (Bits [15–8])
1	0	Low-Byte Transfer (Bits [7–0])
1	1	Refresh

The bhe_n does not require latching and during bus hold and reset is tristated. It is asserted during t_1 and remains so through t_3 and t_w .

The high- and low-byte write enable functions of bhe_n and ad0 are performed by whb_n and wlb_n, respectively.

When using the *ad* bus, DRAM refresh cycles are indicated by bhe_n/aden_n and ad0 both being high. During refresh cycles the *a* and *ad* busses may not have the same address during the address phase of the *ad* bus cycle necessitating the use of ad0 as a determinant for the refresh cycle rather than a0.

An additional signal is used for Pseudo-Static RAM (PSRAM) refreshes (see mcs3_n/rfsh_n pin description).

There is a weak internal pull-up on bhe_n/aden_n obviating the need for an external pull-up and reducing power consumption.

Holding *aden_n* high or letting it float during POR passes control of the address function of the *ad* bus (*ad15–ad0*) during LCS and UCS bus cycles from *aden_n* to the Disable Address (DA) bit in Low-Memory Chip Select (LMCS) and Upper Memory Chip Select (UMCS) registers. When the address function is selected, the memory address is placed on the *a19–a0* pins.

Holding *aden_n* low during POR, both the address and data are driven onto the *ad* bus independently of the DA bit setting. This pin is normally sampled one clock cycle after the rising edge of *res_n*.

2.2.8 *clkouta*—Clock Output A (synchronous output)

This pin is the internal clock output to the system. Bits [9–8] and Bits [2–0] of the Power-Save Control register (PDCON) control the output of this pin, which may be tristated, output the crystal input frequency (x1), or output the power save frequency (internal processor frequency after divisor). The *clkouta* can be used as a full-speed clock source in power-save mode. The AC timing specifications that are clock-related refer to *clkouta*, which remains active during reset and hold conditions.

2.2.9 *clkoutb*—Clock Output B (synchronous output)

This pin is an additional clock output to the system. Bits [11–10] and [2–0] of the Power-Save Control register (PDCON) control the output of this pin, which may be tristated, output the PLL frequency, or may output the power-save frequency (internal processor frequency after divisor). The *clkoutb* remains active during reset and hold conditions.

2.2.10 *den_n/pio5*—Data Enable Strobe (synchronous output with tristate)

This pin provides an output enable to an external bus data bus transmitter or receiver. This signal is asserted during I/O, memory, and interrupt acknowledge processes and is deasserted when *dt/r_n* undergoes a change of state. It is tristated for a bus hold or reset.

2.2.11 *drq1/pio12–drq0/pio13*—DMA Requests (synchronous level-sensitive inputs)

An external device that is ready for DMA channel 1 or 0 to carry out a transfer indicates to the microcontroller this readiness on these pins. They are level triggered, internally synchronized, not latched, and must remain asserted until dealt with.

2.2.12 *dt/r_n/pio4*—Data Transmit or Receive (synchronous output with tristate)

The microcontroller transmits data when *dt/r_n* is pulled high and receives data when this pin is pulled low. It floats during a reset or bus hold condition.

2.2.13 *gnd*—Ground

Six or seven pins, depending on package, connect the microcontroller to the system ground.

2.2.14 **hlda—Bus Hold Acknowledge (synchronous output)**

This pin is pulled high to signal the system that the microcontroller has ceded control of the local bus, in response to a high on the hold signal by an external bus master, after the microcontroller has completed the current bus cycle. The assertion of *hlda* is accompanied by the tristating of *den_n*, *rd_n*, *wr_n*, *s2_n*–*s0_n*, *ad15*–*ad0*, *s6*, *a19*–*a0*, *bhe_n*, *whb_n*, *wlb_n*, and *dt/r_n*, followed by the driving high of the chip selects *ucs_n*, *lcs_n*, *mcs3_n*–*mcs0_n*, *pcs6_n*–*pcs5_n*, and *pcs3_n*–*pcs0_n*. The external bus master releases control of the local bus by the deassertion of hold that in turn induces the microcontroller to deassert the *hlda*. The microcontroller can take control of the bus if necessary (to execute a refresh for example), by deasserting *hlda* without the bus master first deasserting hold. This requires that the external bus master be able to deassert hold to permit the microcontroller to access the bus.

2.2.15 **hold—Bus Hold Request (synchronous level-sensitive input)**

This pin is pulled high to signal the microcontroller that the system requires control of the local bus.

The *hold* latency time (time between the *hold* and *hlda*) depends on the current processor activity when the hold is received. A hold request is second only to a DMA refresh request in priority of processor activity requests. If a hold request is received at the moment a DMA transfer starts, the hold latency can be up to 4 bus cycles. (This happens only on the IA186EM when a word transfer is taking place from an odd to an odd address.) This means that the latency may be 16 clock cycles without wait states. Furthermore, if lock transfers are being performed, then the latency time is increased during the locked transfer.

2.2.16 **int0—Maskable Interrupt Request 0 (asynchronous input)**

The *int0* pin provides an indication that an interrupt request has occurred, and provided that *int0* is not masked, program execution will continue at the location specified by the *INT0* vector in the interrupt vector table. Although interrupt requests are asynchronous, they are synchronized internally and may be edge- or level-triggered. To ensure that it is recognized, the assertion of the interrupt request must be maintained until it is handled.

2.2.17 **int1/select_n—Maskable Interrupt Request 1/Slave Select (both are asynchronous inputs)**

The *int1* pin provides an indication that an interrupt request has occurred, and provided that *int1* is not masked, program execution will continue at the location specified by the *int1* vector in the interrupt vector table. Although interrupt requests are asynchronous, they are synchronized internally and may be edge- or level-triggered. To ensure that it is recognized, the assertion of the interrupt request must be maintained until it is handled.

The `select_n` pin provides an indication to the microcontroller that an interrupt type has been placed on the address/data bus when the internal Interrupt Control Unit is slaved to an external interrupt controller. Before this can occur, however, the `int0` pin must have already indicated an interrupt request has occurred.

2.2.18 int2/inta0_n/pio31—Maskable Interrupt Request 2 (asynchronous input)/Interrupt Acknowledge 0 (synchronous output)

The `int2` pin provides an indication that an interrupt request has occurred, and provided that `int2` is not masked, program execution will continue at the location specified by the `int2` vector in the interrupt vector table. Although interrupt requests are asynchronous, they are synchronized internally and may be edge- or level-triggered. To ensure that it is recognized, the assertion of the interrupt request must be maintained until it is handled. When `int0` is configured to be in cascade mode, `int2` changes its function to `inta0_n`.

The `inta0_n` function indicates to the system that the microcontroller requires an interrupt type in response to the interrupt request `int0` when the microcontroller's Interrupt Control Unit is in cascade mode. The peripheral device that issued the interrupt must provide the interrupt type.

2.2.19 int3/inta1_n/irq—Maskable Interrupt Request 3 (asynchronous input)/Interrupt Acknowledge 1 (synchronous output)/Interrupt Acknowledge (synchronous output)

The `int3` pin provides an indication that an interrupt request has occurred. If `int3` is not masked, program execution will continue at the location specified by the `int3` vector in the interrupt vector table. Although interrupt requests are asynchronous, they are synchronized internally and may be edge- or level-triggered. To ensure that it is recognized, the assertion of the interrupt request must be maintained until it is handled. When `int1` is configured to be in cascade mode, `int3` changes its function to `inta1_n`.

The `inta1_n` function indicates to the system that the microcontroller requires an interrupt type in response to the interrupt request `int1` when the microcontroller's Interrupt Control Unit is in cascade mode. The peripheral device that issued the interrupt must provide the interrupt type.

The signal on `irq` allows the microcontroller to output an interrupt request to the external master interrupt controller when the Interrupt Control Unit of the microcontroller is in slave mode.

2.2.20 int4/pio30—Maskable Interrupt Request 4 (asynchronous input)

The `int4` pin provides an indication that an interrupt request has occurred, and provided that `int4` is not masked, program execution will continue at the location specified by the `int4` vector in the interrupt vector table. Although interrupt requests are asynchronous, they are synchronized internally and may be edge- or level-triggered. To ensure that it is recognized, the assertion of the interrupt request must be maintained until it is handled.

2.2.21 lcs_n/once0_n—Lower Memory Chip Select (synchronous output with internal pull-up)/ONCE Mode Request (input)

The lcs_n pin provides an indication that a memory access is occurring to the lower memory block. The size of the Lower Memory Block and its base address are programmable, with the size adjustable up to 512 Kbytes. The lcs_n is held high during bus hold.

The once0_n pin (ONCE – ON Circuit Emulation) and its companion pin, once1_n, define the microcontroller mode during reset. These two pins are sampled on the rising edge of res_n and if both are asserted low the microcontroller starts in ONCE mode, else it starts normally. In ONCE mode, all pins are tristated and remain so until a subsequent reset. To prevent the microcontroller from entering ONCE mode inadvertently, this pin has a weak pull-up that is only present during reset. This pin is not tristated during bus hold.

2.2.22 mcs2_n—mcs0_n (no pio, pio15, pio 14)—Midrange Memory Chip Selects (synchronous outputs with internal pull-up)

The mcs2_n and mcs0_n pins provide an indication that a memory access is in progress to the second or third midrange memory block. The size of the Midrange Memory Block and its base address are programmable. The mcs2_n – mcs0_n are held high during bus hold and have weak pull-ups that are only present during reset.

2.2.23 mcs3_n/rfsh_n (pio25)—Midrange Memory Chip Select (synchronous output with internal pull-up)/Automatic Refresh (synchronous output)

The mcs3_n pin provides an indication that a memory access is in progress to the fourth region of the midrange memory block. The size of the Midrange Memory Block and its base address are programmable. The mcs3_n is held high during bus hold and has a weak pull-up that is present only during reset.

The rfsh_n signal is timed for auto refresh to PSRAM or DRAM devices. The refresh pulse is output only when the PSRAM or DRAM mode bit is set (EDRAM register Bit [15]). This pulse is of 1.5 clock-pulse duration with the rest of the refresh cycle made up of a deassertion period such that the overall refresh time is met. This pin is not tristated during a bus hold.

2.2.24 nmi—Nonmaskable Interrupt (synchronous edge-sensitive input)

Unlike int4 – int0, this is the highest priority interrupt signal and cannot be masked. Upon the assertion of this interrupt (transition from Low to High), program execution is transferred to the nonmaskable interrupt vector in the interrupt vector table and this interrupt is initiated at the next instruction boundary. For recognition to be assured, the nmi pin must be held high for at least a clkouta period so that the transition from low to high is latched and synchronized internally. The interrupt will begin at the next instruction boundary.

The nmi is not involved in the priority resolution process that deals with the maskable interrupts and does not have an associated interrupt flag. This allows for a new nmi request to interrupt an nmi service routine that is already underway. When an interrupt is taken by the processor the interrupt flag IF is cleared, disabling the maskable interrupts. If the maskable interrupts are reenabled during the nmi service routine (e.g., by use of STI instruction), the priority resolution of maskable interrupts will be unaffected by the servicing of the non-maskable interrupt (NMI).

Note: For this reason, it is strongly recommended that the NMI interrupt service routine does not enable the maskable interrupts.

2.2.25 pcs3_n–pcs0_n (pio19–pio16)—Peripheral Chip Selects 3–0 (synchronous outputs)

The pcs3_n–pcs0_n pins provide an indication that a memory access is underway for the corresponding region of the peripheral memory block (I/O or memory address space). The base address of the peripheral memory block is programmable. The pins are held high during both bus hold and reset. These outputs are asserted with the *ad* address bus over a 256-byte range each.

2.2.26 pcs5_n/a1—Peripheral Chip Select 5 (synchronous output)/Latched Address Bit 1 (synchronous output)

The pcs5_n signal provides an indication that a memory access is underway for the sixth region of the peripheral memory block (I/O or memory address space). The base address of the peripheral memory block is programmable. The pcs5_n is held high during both bus hold and reset. This output is asserted with the *ad* address bus over a 256-byte range.

This a1 pin provides an internally latched address bit 1 to the system when the EX bit (Bit [7]) in the mcs_n and pcs_n auxiliary (MPCS) register is 0. It retains its previously latched value during a bus hold.

2.2.27 pcs6_n/a2—Peripheral Chip Select 6 (synchronous output)/latched Address Bit 2 (synchronous output)

The pcs6_n signal provides an indication that a memory access is underway for the seventh region of the peripheral memory block (I/O or memory address space). The base address of the peripheral memory block is programmable. The pcs6_n is held high during both bus hold and reset. This output is asserted with the *ad* address bus over a 256-byte range.

The a2 pin provides an internally latched address Bit [2] to the system when the EX bit (Bit [7]) in the mcs_n and pcs_n auxiliary (MPCS) register is 0. It retains its previously latched value during a bus hold.

2.2.28 pio31–pio0—Programmable I/O Pins (asynchronous input/output open-drain)

There are 32 individually programmable I/O pins provided (see [Table 15, Default Status of PIO Pins at Reset](#)).

2.2.29 rd_n—Read strobe (synchronous output with tristate)

The rd_n pin provides an indication to the system that a memory or I/O read cycle is underway. It will not be asserted before the *ad* bus is floated during the address to data transition. The rd_n is tristated during bus hold.

2.2.30 res_n—Reset (asynchronous level-sensitive input)

The res_n pin forces a reset on the microcontroller. Its Schmitt trigger allows POR generation via an RC network. When this signal is asserted, the microcontroller immediately terminates its present activity, clears its internal logic, and transfers CPU control to the reset address, FFFF0h.

The res_n must be asserted for at least 1 ms. Because it is synchronized internally it may be asserted asynchronously to clkouta. Furthermore, v_{cc} must be within specification and clkouta must be stable for more than four of its clock periods for the period that res_n is asserted.

The microcontroller starts to fetch instructions 6.5 clkouta clock periods after the deassertion of res_n.

2.2.31 rfs2_n/aden_n (IA188EM)—Refresh 2 (synchronous output with tristate)/Address Enable (input with internal pull-up)

The rfs2_n indicates that a DRAM refresh cycle is being performed when it is asserted low. However, this is not valid in PSRAM mode where mcs3_n/rfs_n is used instead.

If the aden_n pin is held high during POR, the *ad* bus (ao15–ao8 and ad7–ad0 for the IA188EM) is controlled during the address portion of the lcs and ucs bus cycles by the DA bit (Bit [7]) in the lcs and ucs registers. If the DA bit is 1, the address is accessed on the a19–a0 pins, reducing power consumption. The weak pull-up on this pin obviates the necessity of an external pull-up.

If the aden_n pin is held low during POR, the *ad* bus is used for both addresses and data without regard for the setting of the DA bits. The rfs2_n/aden_n is sampled one crystal clock cycle after the rising edge of res_n and is tristated during bus holds and ONCE mode.

2.2.32 rxd/pio28—Receive Data (asynchronous input)

This signal connects asynchronous serial receive data from the system to the asynchronous serial port.

2.2.33 s2_n–s0_n—Bus Cycle Status (synchronous outputs with tristate)

These three signals inform the system of the type of bus cycle in progress. The s2_n may be used to indicate whether the current access is to memory or I/O, and s1_n may be used to indicate whether data is being transmitted or received. These signals are tristated during bus hold and hold acknowledge. The coding for these pins is presented in Table 10.

Table 10. Bus Cycle Types for s2_n, s1_n, and s0_n

s2_n	s1_n	s0_n	Bus Cycle
0	0	0	Interrupt acknowledge
0	0	1	Read data from I/O
0	1	0	Write data to I/O
0	1	1	Halt
1	0	0	Instruction fetch
1	0	1	Read data from memory
1	1	0	Write data to memory
1	1	1	None (passive)

2.2.34 s6/clckdiv2_n/pio29—Bus Cycle Status Bit 6 (synchronous output)/Clock Divide by 2 (input with internal pull-up)

The s6 signal is high during the second and remaining cycle periods (i.e., t₂ – t₄), indicating that a DMA-initiated bus cycle is underway. The s6 is tristated during bus hold or reset.

If the clckdiv2_n signal is held low during power-on-reset, the microcontroller enters clock divide-by-2 mode. In this mode, the PLL is disabled and the processor receives the external clock divided by 2. Sampling of this pin occurs on the rising edge of res_n.

Note: If this pin is used as pio29 and configured as an input, care should be taken that it is not driven low during POR.

Because this pin has an internal pull-up, it is not necessary to drive the pin high even though it defaults to an input PIO.

2.2.35 sclk—Serial Clock (synchronous outputs with tristate)

Because this pin provides a slave device with a synchronous serial clock it permits synchronization of the transmit and receive data exchanges between the slave and the microcontroller. The sclk is the result of dividing the internal clock by 2, 4, 8, or 16, depending on the contents of the Synchronous Serial Control (SSC) register Bits [5–4]. Accessing either the SSR or SSD registers activates the sclk for eight cycles. When sclk is not active, the microcontroller hold is high.

2.2.36 sdata—Serial Data (synchronous inout)

The sdata pin connects a slave device to synchronous serial transmit and receive data. The last value is retained on this pin when it is inactive.

2.2.37 sden1–sden0—Serial Data Enables (synchronous outputs with tristate)

The sden1–sden0 pins facilitate the transfer of data on ports 1 and 0 of the Synchronous Serial Interface (SSI). Either sden1 or sden0 is asserted by the microcontroller at the start of the data transfer and is de-asserted when the transfer is completed. These pins are held low by the microcontroller when they are inactive.

2.2.38 srdy/pio6—Synchronous Ready (synchronous level-sensitive input)

This signal is an active high input synchronized to clkouta and indicates to the microcontroller that a data transfer will be completed by the addressed memory space or I/O device.

In contrast to the Asynchronous Ready (ardy), which requires internal synchronization, srdy permits easier system timing because it already synchronized. Tying srdy high will always assert this ready condition. Tying it low will give control to ardy.

2.2.39 tmrin0/pio11—Timer Input 0 (synchronous edge-sensitive input)

This signal may be either a clock or control signal for the internal Timer 0. The timer is incremented by the microcontroller after it synchronizes a rising edge of tmrin0. When not used, tmrin0 must be tied high, or when used as pio11, it is pulled up internally.

2.2.40 tmrin1/pio0—Timer Input 1 (synchronous edge-sensitive input)

This signal may be either a clock or control signal for the internal Timer 1. The timer is incremented by the microcontroller after it synchronizes a rising edge of tmrin1. When not used, tmrin1 must be tied high, or when used as pio0, it is pulled up internally.

2.2.41 tmrout0/pio10—Timer Output 0 (synchronous output)

This signal provides the system with a single pulse or a continuous waveform with a programmable duty cycle. It is tristated during a bus hold or reset.

2.2.42 tmrout1/pio1—Timer Output 1 (synchronous output)

This signal provides the system with a single pulse or a continuous waveform with a programmable duty cycle. It is tristated during a bus hold or reset.

2.2.43 txd/pio22—Transmit Data (asynchronous output)

This pin provides the system with asynchronous serial transmit data from the serial port.

2.2.44 ucs_n/once1_n—Upper Memory Chip Select (synchronous output)/ONCE Mode Request 1 (input with internal pull-up)

The ucs_n pin provides an indication that a memory access is in progress to the upper memory block. The size of the Upper Memory Block and its base address are programmable, with the size adjustable to 512 Kbytes. The ucs_n is held high during bus hold.

After power-on-reset, ucs_n is active low and program execution begins at FFFF0h. Its default configuration is a 64-Kbyte memory range from F0000h to FFFFFh.

The once0_n pin (ONCE – ON Circuit Emulation) and its companion pin, once1_n, define the microcontroller mode during reset. These two pins are sampled on the rising edge of res_n and if both are asserted low the microcontroller starts in ONCE mode, else it starts normally. In ONCE mode, all pins are tristated and remain so until a subsequent reset. To prevent the microcontroller from entering ONCE mode inadvertently, this pin has a weak pull-up that is only present during reset. This pin is not tristated during bus hold.

2.2.45 uzi_n/pio26—Upper Zero Indicate (synchronous output)

This pin allows the designer to determine if an access to the interrupt vector table is in progress by ORing it with Bits [15–10] of the address and data bus (ad15–ad10 on the IA186EM and ao15–ao10 on the IA188EM). The uzi_n is the logical OR of the inverted a19–a16 bits. It asserts in the first period of a bus cycle and is held throughout the cycle.

At reset, uzi_n should be pulled high or allowed to float. If this pin is pulled low at reset, the microcontroller enters a reserved clock test mode.

2.2.46 v_{cc}—Power Supply (input)

These pins supply power (+5V \pm 10%) to the microcontroller.

2.2.47 whb_n (IA186EM)—Write High Byte (synchronous output with tristate)

The whb_n and wlb_n pins indicate to the system which bytes of the data bus (upper, lower, or both) are taking part in a write cycle. The whb_n is asserted with ad15–ad8 and is the logical OR of bhe_n and wr_n. It is tristated during reset.

2.2.48 wlb_n/wb_n—Write Low Byte (IA186EM) (synchronous output with tristate)/Write Byte (IA188EM) (synchronous output with tristate)

The wlb_n and whb_n pins indicate to the system which bytes of the data bus (upper, lower, or both) are taking part in a write cycle. The wlb_n is asserted with ad7–ad0 and is the logical OR of ad0 and wr_n. It is tristated during reset.

On the IA188EM microcontroller, `wb_n` provides an indication that a write to the bus is occurring. It shares the same early timing as that of the non-multiplexed address bus, and is associated with `ad7–ad0`. It is tristated during reset.

2.2.49 `wr_n`—Write Strobe (synchronous output)

The `wr_n` pin indicates to the system that the data currently on the bus is to be written to a memory or I/O device. It is tristated during a bus hold or reset.

2.2.50 `x1`—Crystal Input (input)

The `x1` and `x2` pins are the connections for a fundamental-mode or third-overtone, parallel-resonant crystal used by the internal oscillator circuit. An external clock source for the microcontroller is connected to `x1`. The `x2` is left unconnected.

2.2.51 `x2`—Crystal Input (input)

The `x1` and `x2` pins are the connections for a fundamental-mode or third-overtone, parallel-resonant crystal used by the internal oscillator circuit. An external clock source for the microcontroller is connected to `x1`. The `x2` is left unconnected.

2.3 Pins Used by Emulators

The following pins are used by emulators:

- `a19–a0`
- `ao15–ao8` (on the IA188EM)
- `ad7–ad0`
- `ale`
- `bhe_n/aden_n` (on the IA186EM)
- `clkouta`
- `rfsh2_n/aden_n` (on the IA188EM)
- `rd_n`
- `s2_n–s0_n`
- `s6/lock_n/clkdiv2_n`
- `uzi_n`

Emulators require that `s6/lock_n/clkdiv2_n` and `uzi_n` be configured as their normal functions (i.e., as `s6` and `uzi_n`, respectively). Holding `bhe_n/aden_n` (IA186EM) or `rfsh_n/aden_n` (IA188EM) low during the rising edge of `res_n`, will cause `s6` and `uzi_n` to be configured in their normal functions at reset instead of as PIOs.

3. Maximum Ratings, Thermal Characteristics, and DC Parameters

The absolute maximum ratings, thermal characteristics, and DC parameters are provided in Tables 11 through 13, respectively.

Table 11. IA186EM and IA188EM Absolute Maximum Ratings

Parameter	Rating
Storage Temperature	-65°C to +125°C
Voltage on any Pin with Respect to v_{ss}	-0.5V to $+(v_{cc} + 0.5)$ V

Table 12. IA186EM and IA188EM Thermal Characteristics

Symbol	Characteristic	Value
T_A	Ambient Temperature	-40°C to 85°C

Table 13. DC Characteristics Over Commercial Operating Ranges

Symbol	Parameter Description	Test Conditions	Min	Max	Unit
V_{CC}	Supply Voltage (@ 5V Operation)	-	4.5	5.5	V
V_{IL}	Input Low Voltage (Except x1)	-	-0.5	0.8	V
V_{IL1}	Clock Input Low Voltage (x1)	-	-0.5	0.8	V
V_{IH}	Input High Voltage (Except res_n and x1)	-	2.0	$v_{cc} + 0.5$	V
V_{IH1}	Input High Voltage (res_n)	-	2.4	$v_{cc} + 0.5$	V
V_{IH2}	Clock Input High Voltage (x1)	-	$v_{cc} - 0.8$	$v_{cc} + 0.5$	V
V_{OL}	Output Low Voltages	$I_{OL} = 2.5$ mA ($s2_n-s0_n$)	-	0.45	V
		$I_{OL} = 2.0$ mA (other)	-	0.45	V
V_{OH}	Output High Voltages ^a	$I_{OH} = -2.4$ mA @ 2.4 V	2.4	$v_{cc} + 0.5$	V
		$I_{OH} = -200$ μ A @ $v_{cc} - 0.5$	$v_{cc} - 0.5$	v_{cc}	V
I_{CC}	Power Supply Current @ 0°C	$v_{cc} = 5.5$ V ^b	-	5.9	mA/ MHz
I_{LI}	Input Leakage Current @ 0.5 MHz	0.45 V $\leq V_{IN} \leq v_{cc}$	-	± 10	μ A
I_{LO}	Output Leakage Current @ 0.5 MHz	0.45 V $\leq V_{OUT} \leq v_{cc}$ ^c	-	± 10	μ A
V_{CLO}	Clock Output Low	$I_{CLO} = 4.0$ mA	-	0.45	V
V_{CHO}	Clock Output High	$I_{CHO} = -500$ μ A	$v_{cc} - 0.5$	-	V

^aThe lcs_n/once0_n, mcs3_n-mcs0_n, ucs_n/once1_n, and rd_n pins have weak internal pullup resistors. Loading the lcs_n/once0_n and ucs_n/once1_n pins in excess of $I_{OH} = -200$ μ A during reset can cause the device to go into ONCE mode.

^bCurrent is measured with the device in reset with the x1 and x2 driven and all other non-power pins open but held high or low.

^cTesting is performed with the pins floating, either during hold or by invoking the ONCE mode.

4. Device Architecture

A functional block diagram of the IA186EM/IA188EM is shown in Figure 7. This microcontroller consists of the following functional blocks.

- Bus Interface and Control (BIC)
- Peripheral Control and Registers
- Chip Selects and Control (CSC)
- Programmable I/O
- Clock and Power Management
- DMA
- Interrupt Controller
- Timers
- Asynchronous Serial Ports
- Synchronous Serial Interface

4.1 Bus Interface and Control

BIC manages all accesses to external memory and external peripherals. These peripherals may be mapped either in memory space or I/O space. The BIC supports both multiplexed and non-multiplexed bus operations. Multiplexed address and data are provided on the ad_{15} – ad_0 bus, while a non-multiplexed address is provided on the a_{19} – a_0 bus. The a bus provides address information for the entire bus cycle (t_1 – t_4), while the ad bus provides address information only during the first phase of the bus cycle (t_1). For more details regarding bus cycles, see the AC waveforms at the end of this datasheet.

The IA186EM microcontroller provides two signals that serve as byte write enables, write high byte (whb_n) and write low byte (wlb_n). The IA188EM microcontroller requires only a single write byte (wb_n) signal to support its 8-bit data bus. The whb_n is the logical OR of the bhe_n and wr_n . The wlb_n is the logical OR of ad_0 and wr_n . The wb_n is the logical OR of ad_0 and wr_n . The wb_n is low whenever a byte is written to the IA188EM data bus ad_7 – ad_0 .

The byte write enables are driven in conjunction with the non-multiplexed address bus a_{19} – a_0 to support the timing requirements of common SRAMs.

The BIC also provides support for PSRAM devices. PSRAM is supported in only the lower chip select (lcs_n) area. In order to support PSRAM, the CSC must be appropriately programmed (see [Section 4.7, Chip Selects](#)).

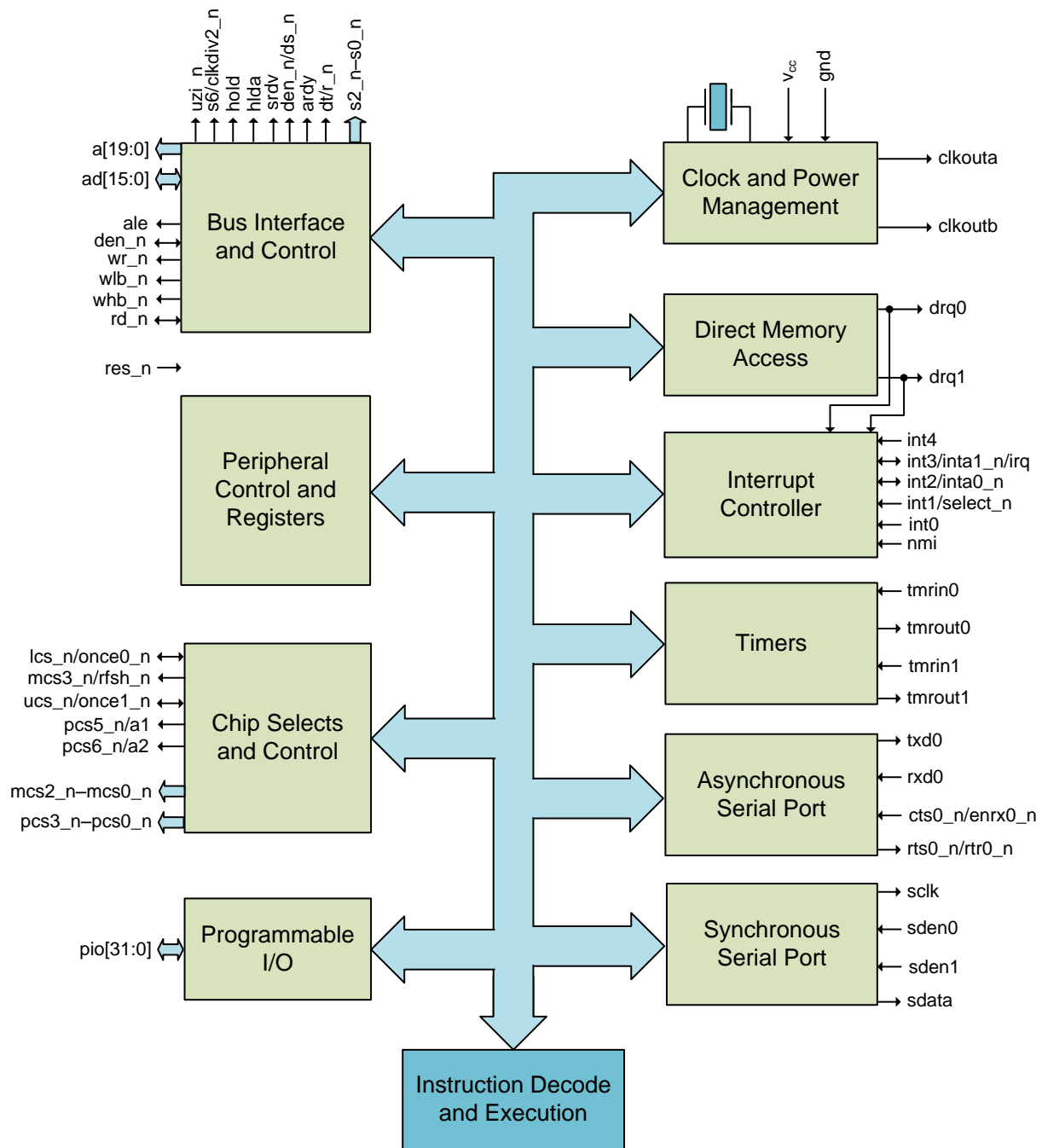

Figure 7. Functional Block Diagram

Note: See pin descriptions for pins that share other functions with PIO pins. Pins pwd , $int5$, $int6$, $rts1_n/rtr1_n$, and $cts1_n/enrx1_n$ are multiplexed with $int2_n/inta0_n$, $drq0_n$, $drq0_n$, $pcs3_n$, and $pcs2_n$, respectively.

4.2 Clock and Power Management

A phase-lock-loop (PLL) and a second programmable system clock output (clkoutb) are included in the clock and power management unit. The internal clock is the same frequency as the crystal but with a duty cycle of 45% to 55 %, as a worst case, generated by the PLL obviating the need for an x2 external clock. A POR resets the PLL (see Figure 8).

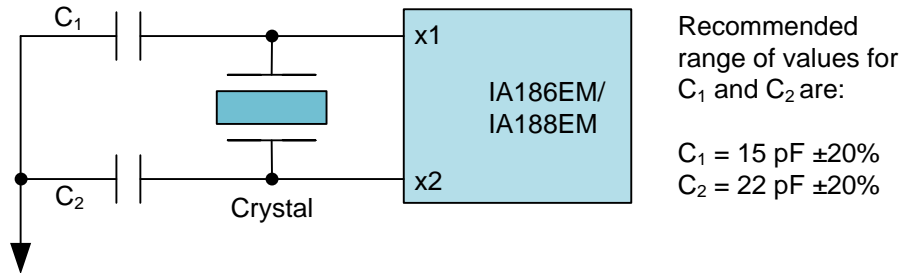

Figure 8. Crystal Configuration

4.3 System Clocks

If required, the internal oscillator can be driven by an external clock source that should be connected to x1, leaving x2 unconnected.

The clock outputs clkouta and clkoutb may be enabled or disabled individually (Power-Save Control register (PDCON) Bits [11–8]). These clock control bits allow one clock output to run at PLL frequency and the other to run at the power-save frequency (see Figure 9).

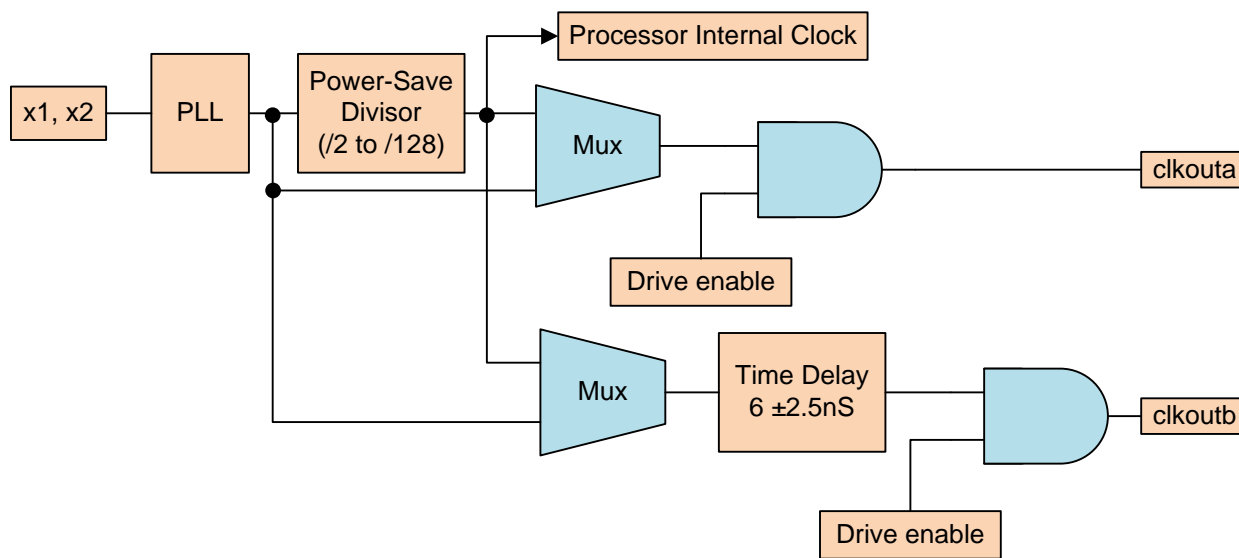

Figure 9. Organization of Clock

4.4 Power-Save Mode

The operation of the CPU and peripherals operate at a slower clock frequency when in power save mode, reducing power consumption and thermal dissipation. Should an interrupt occur, the microcontroller returns to its normal operating frequency automatically on the internal clock's next rising edge in t_3 . Any clock-dependent devices should be reprogrammed for the change in frequency during the power-save mode period.

4.5 Initialization and Reset

The highest priority interrupt, res_n (Reset) must be held low for 1 mS during power-up to initialize the microcontroller correctly. This operation makes the device cease all instruction execution and local bus activity. The microcontroller begins instruction execution at physical address FFFF0h when res_n becomes inactive and after an internal processing interval with ucs_n is asserted and three wait states. Reset also sets up certain registers to predetermined values and resets the Watchdog timer.

4.6 Reset Configuration Register

The data on the address/data bus (ad_{15-0} for the IA186EM, ao_{15-8} and ad_{7-0} for the IA188EM) are written into the Reset Configuration register when reset is low. This data is system dependent and is held in the Reset Configuration register after Reset is de-asserted. This configuration data may be placed on the address/data bus by using weak external pull-up and pull-down resistors or applied to the bus by an external driver, as the processor does not drive the bus during reset. It is a method of supplying the software with some initial data after a reset; for example, option jumper positions.

4.7 Chip Selects

Chip-select generation is programmable for memories and peripherals. Programming is also available to produce ready- and wait-state generation plus latched address bits a1 and a2. For all memory and I/O cycles, the chip-select lines are active within their programmed areas, regardless of whether they are generated by the internal DMA unit or the CPU.

There are six chip-select outputs for memories and a further six for peripherals whether in memory or I/O space. The memory chip-selects are able to address three memory ranges, whereas the peripheral chip-selects are used to address 256-byte blocks that are offset from a programmable base address. Writing to a chip-select register enables the related logic even if the pin in question has another function (e.g., if the pin is programmed to be a PIO).

4.8 Chip-Select Timing

For normal timing, the ucs_n and lcs_n outputs are asserted with the non-multiplexed address bus.

4.9 Ready- and Wait-State Programming

Each of the memory or peripheral chip-select lines can have a ready signal programmed that can be the ardy or srdy signal. The chip-select control registers (UMCS, LMCS, MMCS, PACS, and MPCS) have a single bit that selects whether the external ready signal is to be used or not (R2, Bit [2]). R1 and R0 (Bits [1–0]) in these registers control the number of wait states that are inserted during each access to a memory or peripheral location (from 0 to 3). The control registers for pcs3_n–pcs0_n use three bits, R3, R1–R0 (Bits [3], [1–0]) to provide 5, 7, 9, and 15 wait-states in addition to the original values of 0 to 3 wait states.

In the case where an external ready has been selected as required, internally programmed wait-states will always be completed before the external ready can finish or extend a bus cycle. As an example, consider a system in which the number of wait states to be inserted has been set to 3. The external ready pin is sampled by the processor during the first wait cycle. The access is completed after 7 cycles (4 cycles plus 3 wait cycles) if the ready is asserted. Alternatively, if the ready is not asserted during the first wait cycle, the access is prolonged until ready is asserted and two more wait states are inserted followed by t₄.

4.10 Chip Select Overlap

Overlapping chip selects are configurations where more than one chip select is asserted for the same physical address. For example, if PCS is configured in I/O space with LCS or any other chip select configured for memory, address 00000h is not overlapping the chip selects.

Note: It is not recommended that multiple chip-select signals be asserted for the same physical address, although it may be inescapable in certain systems. If this is the case, then all overlapping chip-selects must have the same external ready configuration and the same number of wait states to be inserted into access cycles.

Internal signals are employed to access the peripheral control block (PCB) and these signals serve as chip selects that are configured with no wait states and no external ready. Therefore, the PCB can be programmed with addresses that overlap external chip selects only if these chip selects are configured in the same manner.

Note: Caution is advised in the use of the DA bit in the LMCS or UMCS registers when overlapping an additional chip select with either the lcs_n or ucs_n. Setting the DA bit to 1 prevents the address from being driven onto the AD bus for all accesses for which the respective chip select is active, including those for which multiple selects are active.

The mcs_n and pcs_n pins are dual-purpose pins, either as chip selects or PIO inputs or outputs. However, the respective ready- and wait-state configurations for their chip-select function will be in effect regardless of the function for which these two pins are programmed. This requires that even if these pins are configured as PIO and enabled (by writing to the MMCS and MPCS registers for the mcs_n chip selects and to the PACS and MPCS registers for the pcs_n chip selects), the ready- and wait-state settings for them must agree with those for any overlapping chip selects as though they were configured as chip selects.

Although pcs4_n is not available as an external pin, it has ready- and wait-state logic and must follow the rules for overlapping chip-selects. Conversely, pins pcs6_n and pcs5_n have ready- and wait-state logic that is disabled when configured as address bits a2 and a1, respectively.

Note: If chip-select configuration rules are not followed, the processor may hang with the appearance of waiting for a ready signal even in a system where ready (ardy or srdy) is always set to 1.

4.11 Upper Memory Chip Select

The ucs_n chip select is for the top of memory. On reset, the microcontroller begins fetching and executing instructions at memory location FFFF0h. As a result, upper memory is usually used for instruction memory. To this end, ucs_n is active on reset and has a memory range of 64 Kbytes (F0000h to FFFFFh) by default, along with external ready required and 3 wait states automatically inserted. The lower boundary of ucs_n is programmable to provide ranges of 64 to 512 Kbytes.

4.12 Low Memory Chip Select

The lcs_n chip-select is for lower memory. As the interrupt vector table is at the bottom of memory beginning at 00000h, this pin is usually used for control data memory. Unlike ucs_n, this pin is inactive on reset, but can be activated by any read or write to the LMCS register.

4.13 Midrange Memory Chip Selects

There are four midrange chip selects, mcs3_n–mcs0_n, which may be used in a user-located memory block. With some exceptions, the base address of the memory block may be located anywhere in the 1-Mbyte memory address space (those used by the ucs_n and lcs_n chip selects, as well as the pcs6_n, pcs5_n, and pcs3_n–pcs0_n, are excluded). If the pcs_n chip selects are mapped to I/O space, then the MCS address range can overlap the PCS address range.

Both the Midrange Memory Chip Select (MMCS) register and the MCS and PCS auxiliary (MPCS) registers are used to program the four midrange chip selects. The MPCS register is used to configure the block size, whereas the MMCS register configures the base address, the ready condition, and the wait states of the memory block accessed by the mcs_n pin. The chip selects (mcs3_n–mcs0_n) are activated by performing a read or write operation of the MMCS and MPCS registers. The assertion of the MCS outputs occurs with the same timing as the multiplexed AD address bus (ad15–ad0 on the IA186EM or ao15–ao8 and ad7–ad0 on the IA188EM). The a19–a0 may be used for address selection, but the timing will be delayed by a half clock cycle over the timing used for the ucs_n and lcs_n.

4.14 Peripheral Chip Selects

There are six peripheral chip selects (pcs6_n, pcs5_n, and pcs3_n–pcs0_n) that may be used within a user-defined memory or I/O block. The base address of this user-defined memory block can be located anywhere within the 1-Mbyte memory address space except for the spaces associated with the ucs_n, lcs_n, and mcs_n chip selects. Or it may be programmed to the 64 Kbyte I/O space. The pcs4_n is not available.

Both the Peripheral Chip Select (PACS) register and the MCS and PCS Auxiliary register (MPCS) registers are used to program the six peripheral chip selects pcs6_n, pcs5_n, and pcs3_n–pcs0_n. The PACS register sets the base address, the ready condition, and the wait states for the pcs3_n–pcs0_n outputs.

The MPCS register configures pcs6_n and pcs5_n pins as either chip selects or address pins a1 and a2, respectively. When these pins are chip selects, the MPCS register also configures them as being active during memory or I/O bus cycles and during their ready and wait states.

None of the pcs_n pins are active at reset. Both the Peripheral Chip Select (PACS) register and the MCS and PCS Auxiliary register (MPCS) registers must be read or written to activate the pcs_n pins as chip selects.

The pcs6_n and pcs5_n may be programmed to have 0 to 3 wait states, whereas pcs3_n–pcs0_n may be programmed to have these and 5, 7, 9, and 15 wait states.

4.15 Refresh Control

The Refresh Control Unit (RCU) generates refresh bus cycles. The RCU generates a memory read request after a programmable period of time to the bus interface unit.

The ENA bit in the Enable RCU register (EDRAM) enables refresh cycles, operating off the processor internal clock. If the processor is in power-save mode, the RCU must be reconfigured for the new clock rate.

If the hlda pin is asserted when a refresh request is initiated (indicating a bus hold condition), the processor disables the hlda pin to allow a refresh cycle to be performed. The external circuit bus master must deassert the *hold* signal for at least one clock period to permit the execution of the refresh cycle.

4.16 Interrupt Control

Interrupt requests originate from a variety of internal and external sources that are arranged by the internal interrupt controller in priority order and presented one by one to the processor.

Six external interrupt sources—five maskable (int4–int0) and one nonmaskable (NMI)—are connected to the processor and six internal interrupt sources (three timers, two DMA channels, and the asynchronous serial port that are not brought out to external pins).

The five external maskable interrupt request pins can be used as direct interrupt requests. However, should more interrupts be needed, int3–int0 may be used with the 82C59A-compatible external interrupt controller. By programming the internal interrupt controller to slave mode, a 82C59A-compatible external interrupt controller can be used as the system master. Interrupt nesting can be used in all cases that permit interrupts of a higher priority to interrupt those of a lower priority.

When an interrupt is accepted, other interrupts are disabled, but may be re-enabled by setting the Interrupt Enable Flag (IF) in the Processor Status Flags register during the Interrupt Service Routine (ISR). Setting IF permits interrupts of equal or greater priority to interrupt the currently running ISR.

Further interrupts from the same source will be blocked until the corresponding bit in the In-Service register (INSERV) is cleared. Special Fully Nested mode (SFNM) is invoked for int0 and int1 by the SFNM bit in the INT0 and INT1 control register, respectively, when this bit is set to 1. In this mode, a new interrupt may be generated by these sources regardless of the in-service bit. The following table shows the priorities of the interrupts at POR.

4.16.1 Interrupt Types

Table 14 presents interrupt names, types, vector table address, End-of-Interrupt (EOI) type, overall priority, and related instructions.

Table 14. Interrupt Types

Interrupt Name	Interrupt Type	Vector Table Address	EOI Type	Overall Priority	Related Instructions
Divide Error Exception ^a	00h	00h	NA	1	DIV, IDIV
Trace Interrupt ^b	01h	04h	NA	1A	All
Non-maskable Interrupt (NMI)	02h	08h	NA	1B	–
Breakpoint Interrupt ^a	03h	0ch	NA	1	INT3
INT0 Detected Overflow Exception ^a	04h	10h	NA	1	INT0
Array Bounds Exception ^a	05h	14h	NA	1	BOUND
Unused Opcode Exception ^a	06h	18h	NA	1	Undefined Opcodes
ESC Opcode Exception ^{a,c}	07h	1ch	NA	1	ESC Opcodes
Timer 0 Interrupt ^{d,e}	08h	20h	08h	2A	–
Timer 1 Interrupt ^{d,e}	12h	48h	08h	2B	–
Timer 2 Interrupt ^{d,e}	13h	4ch	08h	2C	–
Reserved	09h	24h	–	–	–
DMA 0 Interrupt ^e	0ah	28h	0ah	3	–
DMA 1 Interrupt ^e	0bh	2ch	0bh	4	–
INT0 Interrupt	0ch	30h	0ch	5	–
INT1 Interrupt	0dh	34h	0dh	6	–
INT2 Interrupt	0eh	38h	0eh	7	–
INT3 Interrupt	0fh	3ch	0fh	8	–
INT4 Interrupt ^f	10h	40h	10h	9	–
Watchdog Timer Interrupt ^f	11h	44h	11h	9	–
Asynchronous Serial Port Interrupt ^f	14h	50h	14h	9	–
Reserved	15h–1fh	54h–7ch	–	–	–

Note: If the priority levels are not changed, the default priority level will be used for the interrupt sources.

^aInstruction execution generates interrupts.

^bPerformed in the same manner as for the 8086 and 8088.

^cAn ESC opcode causes a trap.

^dBecause only one IRQ is generated for the three timers, they share priority level with other sources. The timers have an interrupt priority order among themselves (2A > 2B > 2C).

^eThese interrupt types are programmable in slave mode.

^fNot available in slave mode.

4.17 Timer Control

The IA186EM and IA188EM each have three 16-bit programmable timers. Timer 0 and Timer 1 each has an input and output connected to external pins that permits it to count or to time events as well as to produce variable duty-cycle waveforms or non-repetitive waveforms. Timer 1 can also be configured as a Watchdog timer.

Because Timer 2 does not have external connections, it is confined to internal functions such as real-time coding, time-delay applications, a prescaler for Timer 0 and Timer 1, or to synchronize DMA transfers.

The Peripheral Control Block contains eleven 16-bit registers to control the programmable timers. Each timer-count register holds the present value of its associated timer and may be read from or written to whether or not the timer is in operation. The microcontroller increments the value of the timer-count register when a timer event takes place.

The value stored in a timer's associated maximum count register determines its maximum count value. Upon reaching it, the timer count register is reset to 0 in the same clock cycle that this count was attained. The timer count register does not store this maximum value. Both Timer 0 and Timer 1 have a primary and a secondary maximum count register that permits each to alternate between two discrete maximum values.

Timer 0 and Timer 1 may have the maximum count registers configured in either primary only or both primary and secondary. If the primary only is configured to operate, on reaching the maximum count, the output pin will go low for one clock period. If both the primary and secondary registers are enabled, the output pin reflects the state of the register in control at the time. This generates the required waveform that is dependent on the two values in the maximum count registers.

Because they are polled every fourth clock period, the timers can operate at a quarter of the internal clock frequency. Although an external clock may be used, the timer output may take six clock cycles to respond to the input.

4.18 Direct Memory Access (DMA)

DMA frees the CPU from involvement in transferring data between memory and peripherals over either one or both high-speed DMA channels. Data may be transferred from memory to I/O, I/O to memory, memory to memory, or I/O to I/O. DMA channels can be connected to the asynchronous serial port.

The IA186EM supports the transfer of both bytes and words to and from even or odd addresses. It does not support word transfers to memory that is configured for byte accesses. The IA188EM does not support word transfers at all. Each data transfer will take two bus cycles (a minimum of 8 clock cycles).

There are three sources of DMA requests for both DMA channels:

- The channel request pin (drq1–drq0)
- Timer 2
- The system software.

Each channel may be programmed to have a different priority either to resolve a simultaneous DMA request or to interrupt a transfer on the other channel.

4.19 DMA Operation

The PCB contains six registers for each DMA channel to control and specify the operation of the channel (see Figure 10):

- Two registers to store a 20-bit source address
- Two registers to store a 20-bit destination address
- One 16-bit transfer-count register
- One 16-bit control register

The number of DMA transfers required is designated in the DMA Transfer Count register and may contain up to 64 Kbytes or words. It will end automatically. DMA channel function is defined by the control registers. Like the other five registers, these may be changed at any time (including during a DMA transfer) and are implemented immediately.

4.20 DMA Channel Control Registers

See [Section 5.1.8, D1CON \(0dah\) and D0CON \(0cah\)](#). The DMA channel control registers specify the following:

- Whether the data destination is in memory or I/O space (Bit [15])
- Whether the destination address is incremented, decremented, or unchanged after each transfer (Bits [14–13])
- Whether the data source is in memory or I/O space (Bit [12])
- Whether the source address is incremented, decremented, or unchanged after each transfer (Bits [11–10])
- Whether DMA transfers cease upon reaching a designated count (Bit [9])
- Whether the last transfer generates an interrupt (Bit [8])
- Synchronization mode (Bits [7–6])

- The relative priority of one DMA channel with respect to the other (Bit [5])
- Acceptance of DMA requests from Timer 2 (Bit [4])
- Byte or Word transfers (Bit [0])

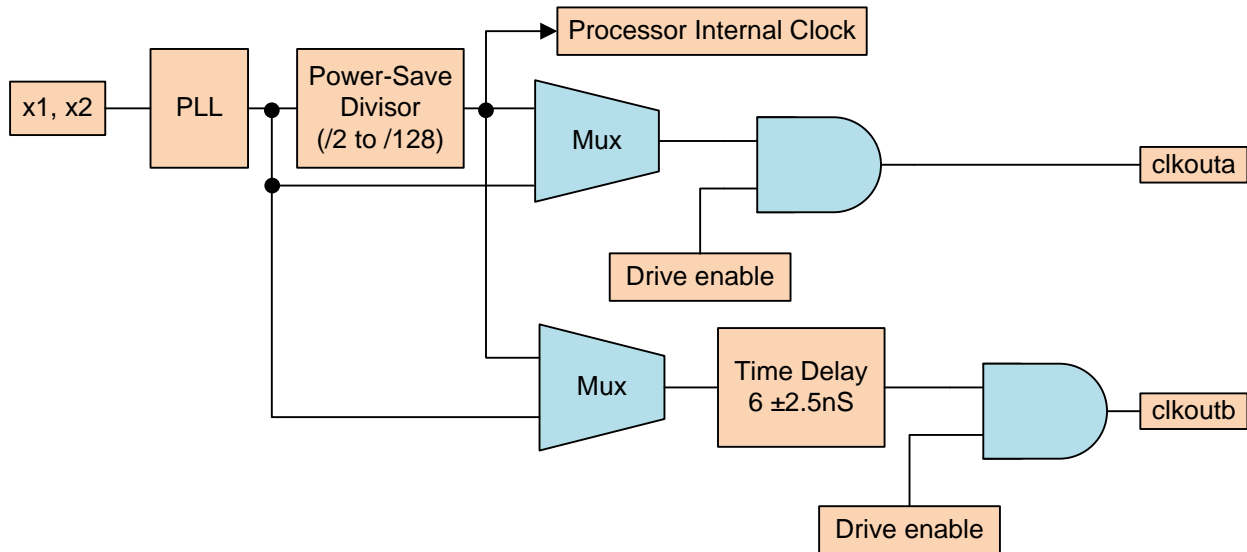

Figure 10. DMA Unit

4.21 DMA Priority

With the exception of word accesses to odd memory locations or between locked memory addresses, DMA transfers have a higher priority than CPU transfers. Because the CPU cannot access memory during a DMA transfer and a DMA transfer cannot be suspended by an interrupt request, continuous DMA activity will increase interrupt delay. An NMI request halts any DMA activity, however, enabling the CPU to respond promptly to the request.

4.22 Asynchronous Serial Port

The asynchronous serial port employs standard industry communication protocols in its implementation of full duplex, bi-directional data transfers. The port can be either the source or destination of DMA transfers.

The following features are supported:

- Full-duplex data transfers
- 7-, 8-, or 9-bit data transfers
- Odd, even, or no parity
- One or two stop bits

- Error detection provided by parity, framing, or overrun errors
- Hardware handshaking is achieved with the following selectable control signals:
 - Clear to send (cts_n)
 - Enable receiver request (enrx_n)
 - Ready to send (rts_n)
 - Ready to receive (rtr_n)
- DMA to and from the port
- The port has its own maskable interrupt
- The port has an independent baud-rate generator
- Maximum baud rate is 1/32 of the processor clock
- Transmit and receive lines are double-buffered

In power-save mode the baud rate generator divide factor must be re-programmed to compensate for the change in clock rate.

4.23 Synchronous Serial Port

The synchronous serial port allows the microcontrollers to communicate with ASICs that are required to be programmed but have a pin shortage. The four-pin interface allows half-duplex, bi-directional data transfer at a maximum of 20 Mbits/sec with a 40-MHz CPU clock.

The synchronous serial interface of the IA186EM/ IA188EM operates as the master port in a master/slave arrangement.

There are four pins in the synchronous serial interface for communication with the system elements. These pins are two enables (SDEN0 and SDEN1), a clock (SCLK), and a data pin (SDATA).

In power-save mode, the baud rate generator divide factor must be re-programmed to compensate for the change in clock rate.

4.24 Programmable I/O (PIO)

Thirty-two pins are programmable as I/O signals (PIO). Table 15 presents them in both numeric and alphabetic order. Because programming a pin as a PIO disables its normal function, it should be done only if the normal function is not required. A PIO pin can be programmed as an input or output with or without a weak pull-up or pull-down. A PIO pin can be also programmed as an open-drain output. Each PIO pin regains default status after a POR.

Table 15. Default Status of PIO Pins at Reset

PIO No.	Associated Pin	Power-On Reset Status	Associated Pin	PIO No.	Power-On Reset Status
0	tmrin1	Input with pull-up	a17	7	Normal operation ^a
1	tmrout1	Input with pull-down	a18	8	Normal operation ^a
2	pcs6_n/a2	Input with pull-up	a19	9	Normal operation ^a
3	pcs5_n/a1	Normal operation ^a	den_n/ds_n	5	Normal operation ^a
4	dt/r_n	Normal operation ^a	drq0	12	Input with pull-up
5	den_n	Normal operation ^a	drq1	13	Input with pull-up
6	sr dy	Normal operation ^a	dt/r_n	4	Normal operation ^a
7 ^b	a17	Normal operation ^a	int2/	31	Input with pull-up
8 ^b	a18	Normal operation ^a	int4	30	Input with pull-up
9 ^b	a19	Normal operation ^a	mcs0_n	14	Input with pull-up
10	tmrout0	Input with pull-down	mcs1_n	15	Input with pull-up
11	tmrin0	Input with pull-up	mcs2_n	24	Input with pull-up
12	drq0	Input with pull-up	mcs3_n/rfsh_n	25	Input with pull-up
13	drq1	Input with pull-up	pcs0_n	16	Input with pull-up
14	mcs0_n	Input with pull-up	pcs1_n	17	Input with pull-up
15	mcs1_n	Input with pull-up	pcs2_n	18	Input with pull-up
16	pcs0_n	Input with pull-up	pcs3_n	19	Input with pull-up
17	pcs1_n	Input with pull-up	pcs5_n/a1	3	Input with pull-up
18	pcs2_n	Input with pull-up	pcs6_n/a2	2	Input with pull-up
19	pcs3_n	Input with pull-up	rx d	28	Input with pull-up
20	scl k	Input with pull-up	s6/cl kdiv2	29	Input with pull-up ^{b,c}
21	sdata	Input with pull-up	scl k	20	Input with pull-up
22	sden0	Input with pull-up	sdata	21	Input with pull-up
23	sden1	Input with pull-up	sden0	22	Input with pull-up
24	mcs2_n	Input with pull-up	sden1	23	Input with pull-up
25	mcs3_n/rfsh_n	Input with pull-up	sr dy	6	Normal operation ^d
26 ^{b,c}	uzi_n	Input with pull-up	tmrin0	11	Input with pull-up
27	tx d	Input with pull-up	tmrin1	0	Input with pull-up
28	rx d	Input with pull-up	tmrout0	10	Input with pull-down
29 ^{b,c}	s6/cl kdiv2	Input with pull-up	tmrout1	1	Input with pull-down
30	int4	Input with pull-up	tx d	27	Input with pull-up
31	int2	Input with pull-up	uzi_n	26	Input with pull-up

^aInput with pullup option available when used as PIO.

^bEmulators use these pins and also a15–a0, ad15–ad0 (IA186EM), ale, bhe_n (IA186EM), clkouta, nmi, res_n, and s2_n–s0_n.

^cIf bhe_n/aden_n (IA186EM) or rfsh_n/aden_n (IA188EM) is held low during POR, these pins will revert to normal operation.

^dInput with pulldown option available when used as PIO.

These default status settings may be changed as desired.

After POR, a19–a17, the three most significant bits of the address bus, start with their normal function, allowing the processor to begin fetching instructions from the boot address FFFF0h. Normal function is also the default setting for dt/r_n, den_n, and srdy after POR.

If the ad15–ad0 bus override is enabled, s6/clkdiv2_n and uzi_n automatically return to normal operation. The ad15–ad0 bus override is enabled if either the bhe_n/aden_n for the IA186EM or the rfsh2_n/aden_n for the IA188EM is held low during POR.

5. Peripheral Architecture

5.1 Control and Registers

The on-chip peripherals in the IA186EM/IA188EM are controlled from a 256-byte block of internal registers. Although these registers are actually located in the peripherals they control, they are addressed within a single 256-byte block of I/O space and are treated as a functional unit. A list of these registers is presented in Table 16.

Although a named register may be 8 bits, write operations performed on the IA188EM should be 8-bit writes, resulting in 16-bit data transfers to the Peripheral Control Block (PCB) register. Only word reads should be performed to the PCB registers. If unaligned read and write accesses are performed on either the IA186EM or IA188EM, indeterminate behavior may result.

Note: Adhere to these directions while writing code to avoid errors.

Table 16. Peripheral Control Registers

Register Name	Offset
Peripheral Control Block Registers	
PCB Relocation Register	FEh
Reset Configuration Register	F6h
Processor Release Level Register	F4h
Power-Save Control Register	F0h
Enable RCU Register	E4h
Clock Prescaler Register	E2h
Memory Partition Register	E0h
DMA Registers	
DMA1 Control Register	DAh
DMA1 Transfer Count Register	D8h
DMA1 Destination Address High Register	D6h
DMA1 Destination Address Low Register	D4h
DMA1 Source Address High Register	D2h
DMA1 Source Address Low Register	D0h
DMA0 Control Register	CAh
DMA0 Transfer Count Register	C8h
DMA0 Destination Address High Register	C6h
DMA0 Destination Address Low Register	C4h
DMA0 Source Address High Register	C2h
DMA0 Source Address Low Register	C0h
Chip-Select Registers	
pcs_n and mcs_n Auxiliary Register	A8h
Mid-Range Memory Chip-Select Register	A6h
Peripheral Chip-Select Register	A4h
Low-Memory Chip-Select Register	A2h
Upper-Memory Chip-Select Register	A0h
Asynchronous Serial Port Register	
Serial Port Baud Rate Divisor Register	88h
Serial Port Receive Register	86h
Serial Port Transmit Register	84h
Serial Port Status Register	82h
Serial Port Control Register	80h
PIO Registers	
PIO Data 1 Register	7Ah
PIO Direction 1 Register	78h
PIO Mode 1 Register	76h
PIO Data 0 Register	74h
PIO Direction 0 Register	72h
PIO Mode 0 Register	70h

Register Name	Offset
Timer Registers	
Timer 2 Mode and Control Register	66h
Timer 2 Max Count Compare A Register	62h
Timer 2 Count Register	60h
Timer 1 Mode and Control Register	5Eh
Timer 1 Max Count Compare B Register	5Ch
Timer 1 Max Count Compare A Register	5Ah
Timer 1 Count Register	58h
Timer 0 Mode and Control Register	56h
Timer 0 Max Count Compare B Register	54h
Timer 0 Max Count Compare A Register	52h
Timer 0 Count Register	50h
Interrupt Registers	
Serial Port 0 Interrupt Control Register	44h
Watchdog Timer Control Register	42h
INT4 Interrupt Control Register	40h
INT3 Interrupt Control Register	3Eh
INT2 Interrupt Control Register	3Ch
INT1 Interrupt Control Register	3Ah
INT0 Interrupt Control Register	38h
DMA1 Interrupt Control Register	36h
DMA0 Interrupt Control Register	34h
Timer Interrupt Control Register	32h
Interrupt Status Register	30h
Interrupt Request Register	2Eh
Interrupt In-Service Register	2Ch
Interrupt Priority Mask Register	2Ah
Interrupt Mask Register	28h
Interrupt Poll Status Register	26h
Interrupt Poll Register	24h
End-of-Interrupt (EOI) Register	22h
Interrupt Vector Register	20h
Serial Port 1 Registers	
Synchronous Serial Receive Register	18h
Synchronous Serial Transmit 0 Register	16h
Synchronous Serial Transmit 1 Register	14h
Synchronous Serial Enable Register	12h
Synchronous Serial Status Register	10h

5.1.1 RELREG (0feh)

The Peripheral Control Block RELocation REGister maps the entire Peripheral Control Block Register Bank to either I/O or memory space. In addition, RELREG contains a bit that places the interrupt controller in either master or slave mode. The RELREG contains 20ffh at reset (see Table 17).

Table 17. Peripheral Control Block Relocation Register

15	14	13	12	11	10	9	8	7	6	5	4	3	2	1	0
Reserved	S/Mn	Reserved	IO/Mn	RA19– RA8											

- Bit [15]—Reserved.
- Bit [14]—S/Mn → When set to 1, this bit places the interrupt controller into slave mode. When 0, it is in master mode.
- Bit [13]—Reserved.
- Bit [12]—IO/Mn → When set to 1, the Peripheral Control Block is mapped into memory space. When 0, this bit maps the Peripheral Control Block Register Bank into IO space.
- Bits [11–0]—RA19–RA8 → Sets the base address (upper 12 bits) of the Peripheral Control Block Register Bank. RA7–RA0 default to 0. When Bit [12] (IO/Mn) is set to 1, RA19–RA16 are ignored.

5.1.2 RESCON (0f6h)

The RESet CONfiguration Register latches user-defined information present at specified pins at the rising edge of reset. The contents of this register are read-only and remain valid until the next reset. The RESCON contains user-defined information at reset (see Table 18).

Table 18. Reset Configuration Register

15	14	13	12	11	10	9	8	7	6	5	4	3	2	1	0
RC15–RC0															

- Bits [15–0]—RC15–RC0 → At the rising edge of reset, the values of specified pins (ad15–ad0 for the IA186EM and ao15–ao8 and ad7–ad0 for the IA188EM) are latched into this register.

5.1.3 PRL (0f4h)

The Processor Release Level Register contains a code corresponding to the latest processor production release. The PRL is a Read-Only Register. The PRL contains 0400h (see Table 19).

Table 19. Processor Release Level Register

15	14	13	12	11	10	9	8	7	6	5	4	3	2	1	0
PRL7–PRL0								Reserved							

- Bits [15–8]—PRL7–PRL0 → The latest Processor Release Level.

<u>PRL Value</u>	<u>Processor Release Level</u>
01h	C
02h	D
03h	E
04h	F

- Bits [7–0]—Reserved.

5.1.4 PDCON (0f0h)

The Power-save CONTROL Register controls several miscellaneous system I/O and timing functions. The PDCON contains 0000h at reset (see Table 20).

Table 20. Power-Save Control Register

15	14	13	12	11	10	9	8	7	6	5	4	3	2	1	0
PSEN	Reserved		CBF	CBD	CAF	CAD	Reserved			F2	F1	F0			

- Bit [15]—PSEN → When set to 1, enables the power-save mode causing the internal operating clock to be divided by the value in F2–F0. External interrupts or interrupts from internal interrupts automatically clear PSEN. Software interrupts and exception do not clear PSEN.

Note: The value of PSEN is not restored upon execution of an IRET instruction.

- Bits [14–12]—Reserved → These bits read back as 0.
- Bit [11]—CBF → When set to 1, the clkoutb output follows the input crystal (PLL) frequency. When 0, it follows the internal clock frequency after the clock divider.
- Bit [10]—CBD → When set to 1, the clkoutb output is pulled low. When 0, it is driven as an output per the CBF bit.
- Bit [9]—CAF → When set to 1, the clkouta output follows the input crystal (PLL) frequency. When 0, it follows the internal clock frequency after the clock divider.

- Bit [8]—CAD → When set to 1, the clkouta output is pulled low. When 0, it is driven as an output per the CBF bit.
- Bits [7–3]—Reserved → These bits read back as 0.
- Bits [2–0]—F2–F0 → These bits control the clock divider as shown below.

Note: PSEN must be 1 for the clock divider to function.

F2	F1	F0	Divider Factor
0	0	0	Divide by 1 (2^0)
0	0	1	Divide by 2 (2^1)
0	1	0	Divide by 4 (2^2)
0	1	1	Divide by 8 (2^3)
1	0	0	Divide by 16 (2^4)
1	0	1	Divide by 32 (2^5)
1	1	0	Divide by 64 (2^6)
1	1	1	Divide by 128 (2^7)

5.1.5 EDRAM (0e4h)

The Enable RCU Register provides control and status for the refresh counter. The EDRAM register contains 0000h at reset (see Table 21).

Table 21. Enable Dynamic RAM Refresh Control Register

15	14	13	12	11	10	9	8	7	6	5	4	3	2	1	0
E	Reserved						T8–T0								

- Bit [15]—E → When set to 1, the refresh counter is enabled and msc3_n is configured to act as rfsn_n. Clearing E empties the refresh counter and disables refresh requests. The refresh address is unaffected by clearing E.
- Bits [14–9]—Reserved → These bits read back as 0.
- Bits [8–0]—T8–T0 → These bits hold the current value of the refresh counter. They are read-only.

5.1.6 CDRAM (0e2h)

The Clock Prescaler Register determines the period between refresh cycles. The Count for Dynamic RAM (CDRAM) register is undefined at reset (see Table 22).

Table 22. Count for Dynamic RAM Refresh Control Register

15	14	13	12	11	10	9	8	7	6	5	4	3	2	1	0
Reserved							RC8–RC0								

- Bits [15–9]—Reserved → These bits read back as 0.
- Bits [8–0]—RC8–RC0 → These bits hold the clock count interval between refresh cycles. In power-save mode, the refresh counter value should be adjusted to account for the clock divider value in PDCON.

Note: This value should not be set to less than 18 (12h), else there would never be sufficient bus cycles available for the processor to execute code.

5.1.7 MDRAM (0e0h)

The Memory Partition Register holds the a19–a13 address bits of the 20-bit base refresh address. The MDRAM register contains 0000h at reset (see Table 23).

Table 23. Memory Partition for Dynamic RAM Refresh Control Register

15	14	13	12	11	10	9	8	7	6	5	4	3	2	1	0
M6–M0							Reserved								

- Bits [15–9]—M6–M0 → Upper bits corresponding to address bits a19–a13 of the 20-bit memory refresh address. These bits are not available on the a19–a0 bus. When using PSRAM mode, M6–M0 must be programmed to 0000000b.
- Bits [8–0]—Reserved → These bits read back as 0.

5.1.8 D1CON (0dah) and D0CON (0cah)

DMA Control Registers. DMA Control Registers control operation of the two DMA channels. The D0CON and D1CON registers are undefined at reset, except ST which is set to 0 (see Table 24).

Table 24. DMA Control Registers

15	14	13	12	11	10	9	8	7	6	5	4	3	2	1	0
DM/IOn	DDEC	DINC	SM/IOn	SDEC	SINC	TC	INT	SYN1–SYN0	P	TDRQ	Res	CHG	ST	Bn/W	

- Bit [15]—DM/IOn → Destination Address Space Select selects memory or I/O space for the destination address. When DM/IO is set to 1, the destination address is in memory space. When 0, it is in I/O space.

- Bit [14]—DDEC → Destination Decrement. When set to 1, it automatically decrements the destination address after each transfer. The address is decremented by 1 or 2, depending on the byte/word bit (Bn/W, Bit [0]). The address does not change if the increment and decrement bits are set to the same value (00b or 11b).
- Bit [13]—DINC → Destination Increment. When set to 1, it automatically increments the destination address after each transfer. The address is incremented by 1 or 2, depending on the byte/word bit (Bn/W, Bit [0]). The address does not change if the increment and decrement bits are set to the same value (00b or 11b).
- Bit [12]—SM/IO_n → Source Address Space Select selects memory or I/O space for the source address. When set to 1, the source address is in memory space. When 0, it is in I/O space.
- Bit [11]—SDEC → Source Decrement. When set to 1, it automatically decrements the destination address after each transfer. The address is decremented by 1 or 2, depending on the byte/word bit (Bn/W, Bit [0]). The address does not change if the increment and decrement bits are set to the same value (00b or 11b).
- Bit [10]—SINC → Source Increment. When set to 1, it automatically increments the destination address after each transfer. The address is incremented by 1 or 2, depending on the byte/word bit (Bn/W, Bit [0]). The address does not change if the increment and decrement bits are set to the same value (00b or 11b).
- Bit [9]—TC → Terminal Count. The DMA decrements the transfer count for each DMA transfer. When set to 1, the source or destination synchronized DMA transfers terminate when the count reaches 0. When 0, they do not. Unsynchronized DMA transfers always end when the count reaches 0, regardless of this bit's setting.
- Bit [8]—INT → Interrupt. When this bit is set to 1, the DMA channel generates an interrupt request on completion of the transfer count. However, for an interrupt to be generated, the TC bit must also be set to 1.
- Bits [7–6]—SYN1–SYN0 → Synchronization Type bits each select channel synchronization types as shown below. The value of these bits is ignored if TDRQ (Bit [4]) is set to 1. A processor reset causes these bits to be set to 11b.

Synchronization Bit Channel Selection

SYN1	SYN0	Sync Type
0	0	Unsynchronized
0	1	Source Synchronized
1	0	Destination Synchronized
1	1	Reserved

- Bit [5]—P → Relative Priority. When set to 1, selects high priority for this channel relative to the other channel during simultaneous transfers.
- Bit [4]—TDRQ → Timer 2 Synchronization. When set to 1, enables DMA requests from Timer 2. When 0, disables them.
- Bit [3]—Reserved.
- Bit [2]—CHG → Change Start Bit. This bit must be set to 1 to allow modification of the ST bit during a write. During a write, when CHG is set to 0, ST is not changed when writing the control word. The result of reading this bit is always 0.
- Bit [1]—ST → Start/Stop DMA Channel. When set to 1, the DMA channel is started. The CHG bit must be set to 1 for this bit to be modified and only during the same register write. A processor reset causes this bit to be set to 0.
- Bit [0]—Bn/W → Byte/Word Select. When set to 1, word transfers are selected. When 0, byte transfers are selected.

Note: Word transfers are not supported if the chip selects are programmed for 8-bit transfers. The IA188EM does not support word transfers

5.1.9 D1TC (0d8h) and D0TC (0c8h)

DMA Transfer Count Registers. The DMA Transfer Count registers are maintained by each DMA channel. They are decremented after each DMA cycle. The state of the TC bit in the DMA control register has no influence on this activity. But, if unsynchronized transfers are programmed or if the TC bit in the DMA control word is set, DMA activity ceases when the transfer count register reaches 0. The D0TC and D1TC registers are undefined at reset (see Table 25).

Table 25. DMA Transfer Count Registers

15	14	13	12	11	10	9	8	7	6	5	4	3	2	1	0
TC15–TC0															

- Bits [15–0]—TC15–TC0 → DMA Transfer Count contains the transfer count for the respective DMA channel. Its value is decremented after each transfer.

5.1.10 D1DSTH (0d6h) and D0DSTH (0c6h)

The DMA DeSTination Address High Register. The 20-bit destination address consists of these 4 bits combined with the 16 bits of the respective Destination Address Low Register. A DMA transfer requires that two complete 16-bit registers (high and low registers) be used for both the source and destination addresses of each DMA channel involved. These four registers must be

initialized. Each address may be incremented or decremented independently of each other after each transfer. The addresses are incremented or decremented by two for word transfers and incremented or decremented by one for byte transfers. They are undefined at reset (see Table 26).

Table 26. DMA Destination Address High Register

15	14	13	12	11	10	9	8	7	6	5	4	3	2	1	0
Reserved												DDA19–DDA16			

- Bits [15–4]—Reserved.
- Bits [3–0]—DDA19–DDA16 → DMA Destination Address High bits are driven onto a19–a16 during the write phase of a DMA transfer.

5.1.11 DIDSTL (0d4h) and D0DSTL (0c4h)

DMA DeSTination Address Low Register. The 16 bits of these registers are combined with the 4 bits of the respective DMA Destination Address High Register to produce a 20-bit destination address. They are undefined at reset (see Table 27).

Table 27. DMA Destination Address Low Register

15	14	13	12	11	10	9	8	7	6	5	4	3	2	1	0
DDA15–DDA0															

- Bits [15–0]—DDA15–DDA0 → DMA Destination Address Low bits are driven onto a15–a0 during the write phase of a DMA transfer.

5.1.12 D1SRCH (0d2h) and D0SRCH (0c2h)

DMA SouRCe Address High Register. The 20-bit source address consists of these 4 bits combined with the 16 bits of the respective Source Address Low Register. A DMA transfer requires that two complete 16-bit registers in the PCB (high and low registers) be used for both the source and destination addresses of each DMA channel involved. Each channel requires that all four address registers be initialized. Each address may be independently incremented or decremented after each word transfer by 2 or by 1 for byte transfers. They are undefined at reset (see Table 28).

Table 28. DMA Source Address High Register

15	14	13	12	11	10	9	8	7	6	5	4	3	2	1	0
Reserved												DSA19–DSA16			

- Bits [15–4]—Reserved.
- Bits [3–0]—DSA19–DSA16 → DMA Source Address High bits are driven onto a19–a16 during the read phase of a DMA transfer.

5.1.13 D1SRCL (0d0h) and D0SRCL (0c0h)

DMA SouRCe Address Low Register. The 16 bits of these registers are combined with the 4 bits of the respective DMA Source Address High register to produce a 20-bit source address. They are undefined at reset (see Table 29).

Table 29. DMA Source Address Low Register

15	14	13	12	11	10	9	8	7	6	5	4	3	2	1	0
DSA15–DSA0															

- Bits [15–0]—DSA15–DSA0 → DMA Source Address Low bits are placed onto a15–a0 during the read phase of a DMA transfer.

5.1.14 MPCS (0a8h)

MCS and PCS (MPCS) Auxiliary Register. Because this register controls more than one type of chip select, it is unlike other chip select control registers. The MPCS register contains information for mcs3_n–mcs0_n, pcs6_n–pcs5_n, and pcs3_n–pcs0_n.

The MPCS register also contains a bit that configures the pcs6_n–pcs5_n pins as either chip selects or as alternate sources for the a2 and a1 address bits. Either a1/a2 or pcs6_n–pcs5_n are selected to the exclusion of the other. When programmed for address bits, these outputs can be used to provide latched address bits for a2 and a1.

The pcs6_n–pcs5_n pins are high and not active on processor reset. When the pcs6_n–pcs5_n are configured as address pins, an access to the MPCS register causes them to activate. They do not require corresponding access to the PACS register to be activated. The value of the MPCS register is undefined at reset (see Table 30).

Table 30. MCS and PCS Auxiliary Register

15	14	13	12	11	10	9	8	7	6	5	4	3	2	1	0
1	M6–M0							EX	MS	Reserved			R2	R1–R0	

- Bit [15]—Reserved → Set to 1.
- Bits [14–8]—M6–M0 mcs_n Block Size → These seven bits determine the total memory block size for the mcs3_n–mcs0_n chip selects. The size is divided equally among them. The relationship between M6–M0 and the size is shown below.

Select Sizes of M6–M0 by Total Block Size

Total Block Size	Individual Select Size	M6–M0
8K	2K	0000001b
16K	4K	0000010b
32K	8K	0000100b
64K	16K	0001000b
128K	32K	0010000b
256K	64K	0100000b
512K	128K	1000000b

- Bit [7]—EX Pin Selector → This bit determines whether the pcs6_n–pcs5_n pins are configured as chip selects or as alternate outputs for a2 and a1. When set to 1, they are configured as peripheral chip select pins. When 0, they become address bits a1 and a2, respectively.
- Bit [6]—MS Memory/I/O Space Selector → This bit determines whether the pcs_n pins are active during either memory or I/O bus cycles. When set to 1, the outputs are active for memory bus cycles. When 0, they are active for I/O bus cycles.
- Bits [5–3]—Reserved → Set to 1.
- Bit [2]—R2 Ready Mode → This bit influences only the pcs6_n–pcs5_n chip selects. When set to 1, external ready is ignored. When 0, it is required. Values determine the number of wait states to be inserted.
- Bits [1–0]—R1–R0 Wait-State Value → These bits influence only the pcs6_n–pcs5_n chip selects. Their value determines the number of wait states inserted into an access, depending on whether it is to the pcs_n memory or I/O area. Up to three wait states can be inserted (R1–R0 = 00b to 11b).

5.1.15 MMCS (0a6h)

Midrange Memory Chip Select (MMCS) Register. Four chip-select pins, mcs3_n–mcs0_n, are provided for use within a user-locatable memory block. Excluding the areas associated with the ucs_n and lcs_n chip selects (and if mapped to memory, the address range of the peripheral chip selects, pcs6_n–pcs5_n and pcs3_n–pcs0_n), the memory block base address can be located anywhere within the 1-Mbyte memory address space. If the pcs_n chip selects are mapped to I/O space, the mcs_n address range can overlap the pcs_n address range.

Two registers program the Midrange Chip Selects. The MMCS register determines the base address, the ready condition, and wait states of the memory block that are accessed through the mcs_n pins. The pcs_n and mcs_n auxiliary (MPCS) register configures the block size. On reset, the mcs3_n–mcs0_n pins are not active. Accessing with a write, both the MMCS and MPCS registers activate these chip selects.

Unlike the *ucs_n* and *lcs_n* chip selects, the *mcs3_n*–*mcs0_n* outputs assert with the multiplexed *ad* address bus (*ad15*–*ad0* for the IA186EM and *ao15*–*ao8* and *ad7*–*ad0* for the IA188EM), rather than the earlier timing of the *a19*–*a0* bus. If the *a19*–*a0* bus is used for address selection, the timing is delayed for a half cycle later than that for *ucs_n* and *lcs_n*. The value is undefined at reset (see Table 31).

Table 31. Midrange Memory Chip Select Register

15	14	13	12	11	10	9	8	7	6	5	4	3	2	1	0
BA19–BA13							Reserved						R2	R1–R0	

- Bits [15–9]—BA19–BA13 Base Address → The value of the this pin determines the base address of the memory block that is addressed by the *mcs_n* chip select pins. These bits correspond to *a19*–*a13* of the 20-bit memory address. The remaining bits *a12*–*a0* of the base address are always 0.
 - The base address may be any integer multiple of the size of the memory clock selected in the MPCS register. For example, if the midrange block is 32 Kbytes, the block could be located at 20000h or 28000h but not at 24000h.
 - If the *lcs_n* chip select is inactive, the base address of the midrange chip selects can be set to 00000h, because the *lcs_n* chip select is defined to be 00000h but is unused. Because the base address must be an integer multiple of the block size, a 512K MMCS block size can only be used with the *lcs_n* chip select inactive and the base address of the midrange chip selects set to 00000h.
- Bits [8–3]—Reserved → Set to 1.
- Bit [2]—R2 Ready mode → This bit determines the *mcs_n* chip select ready mode. When set to 1, an external ready is ignored. When 0, it is necessary. In each case, the number of wait states inserted in an access is determined by the value of the R1 and R0 bits.
- Bits [1–0]—R1–R0 → Wait-State Value. The value of these bits determines the number of wait states inserted in an access. Up to three wait states can be inserted (R1–R0 = 00b to 11b).

5.1.16 PACS (0a4h)

Peripheral Chip Select Register. These Peripheral Chip Selects are asserted over a 256-byte range with the same timing as the *ad* address bus. There are six chip selects, *pcs6_n*–*pcs5_n* and *pcs3_n*–*pcs0_n*, that are used in either the user-locatable memory or I/O blocks. The *pcs4_n* chip select is not implemented in the IA186EM or IA188EM. Excluding the areas used by the *ucs_n*, *lcs_n*, and *mcs_n* chip selects, the memory block can be located anywhere within the

1-Mbyte address space. These chip selects may also be configured to access the 64-Kbyte I/O space.

Programming the Peripheral Chip Selects uses the Peripheral Chip Select (PACS) and the pcs_n and mcs_n Auxiliary (MPCS) registers. The PACS register establishes the base address, configures the ready mode, and determines the number of wait states for the pcs3_n–pcs0_n outputs.

The MPCS register configures the pcs6_n–pcs5_n pins to be either chip selects or address pins a1 and a2. When these pins are configured as chip selects, the MPCS register determines the ready and wait states for these output pins and whether they are active during memory or I/O bus cycles. These pins are activated as chip selects by writing to the two registers (PACS and MPCS). They are not active on reset. To configure and activate them as address pins, it is necessary to write to both the PACS and MPCS registers. Pins pcs6_n–pcs5_n can be configured for 0 to 3 wait states and pcs3_n–pcs0_n can be programmed for 0 to 15 wait states. The value of the PACS register is undefined at reset (see Table 32).

Table 32. Peripheral Chip Select Register

15	14	13	12	11	10	9	8	7	6	5	4	3	2	1	0
BA19–BA11									Reserved		R3	R2	R1–R0		

- Bits [15–7]—BA19–BA11 → Base Address bits correspond to Bits [19–11] of the 20-bit programmable base address of the peripheral chip select block and determine the base address. Because I/O addresses are only 16 bits wide, if the pcs_n chip selects are mapped to I/O space, these bits must be set to 0000b. The pcs address ranges are shown below.

Address Ranges of pcs Chip Selects

pcs_n Line	Range	
	Low	High
pcs0_n	Base Address	Base Address + 255
pcs1_n	Base Address + 256	Base Address + 511
pcs2_n	Base Address + 512	Base Address + 767
pcs3_n	Base Address + 768	Base Address + 1023
Reserved	NA	NA
pcs5_n	Base Address + 1280	Base Address
pcs6_n	Base Address + 1536	Base Address

- Bits [6–4]—Reserved → Set to 1.
- Bit [3]—R3 → Wait State Value. See pcs3_n–pcs0_n Wait-State Encoding shown below.

pcs3_n–pcs0_n Wait-State Encoding

R3	R1	R0	Wait States
0	0	0	0
0	0	1	1
0	1	0	2
0	1	1	3
1	0	0	5
1	0	1	7
1	1	0	9
1	1	1	15

- Bit [2]—R2 → Ready Mode. When set to 1, external ready is ignored. When 0, it is required. In each case the number of wait states is determined according to the pcs3_n–pcs0_n Wait-State Encoding shown above.
- Bits [1–0]—R1–R0 → Wait-State Value (see pcs3_n–pcs0_n Wait-State Encoding above). The pcs6_n–pcs5_n and pcs3_n–pcs0_n pins are multiplexed with the PIO pins. For these to function as chip selects, the PIO mode and direction settings for these pins must be set to 0 for normal operation.

5.1.17 LMCS (0a2h)

The Low-Memory Chip Select (LMCS) Register configures the LMCS provided to facilitate access to the interrupt vector table located at 00000h or the bottom of memory. The lcs_n pin is not active at reset.

The width of the data bus for the lcs_n space should be configured in the AUXCON register before activating the lcs_n chip select pin, by any write access to the LMCS register. The value of the LMCS register is undefined at reset except DA, which is set to 0 (see Table 33).

Table 33. Low-Memory Chip Select Register

15	14	13	12	11	10	9	8	7	6	5	4	3	2	1	0
Res	UB2–UB0			Reserved				DA	PSE	Reserved			R2	R1–R0	

- Bit [15]—Reserved → Set to 0.
- Bits [14–12]—UB2–UB0 → Upper Boundary. These bits define the upper boundary of memory accessed by the lcs_n chip select. The list below presents the possible block-size configurations (a 512-Kbyte maximum).

LMCS Block-Size Programming Values

Memory Block Size	Ending Address	UB2–UB0
64K	0FFFFh	000b
128K	1FFFFh	001b
256K	3FFFFh	011b
512K	7FFFFh	111b

- Bits [11–8]—Reserved → Set to 1.
- Bit [7]—DA → Disable Address. When set to 1, the address bus is disabled, providing some measure of power saving. When 0, the address is driven onto the address bus ad15–ad0 during the address phase of a bus cycle. This bit is set to 0 at reset.
 - If bhe_n/aden_n (IA186EM) is held at 0 during the rising edge of res_n, the address bus is always driven, regardless of the setting of DA.
- Bit [6]—PSE → PSRAM Mode Enable. When set to 1, PSRAM support for the lcs_n chip select memory space is enabled. The EDRAM, MDRAM, and CDRAM RCU registers must be configured for auto refresh before PSRAM support is enabled. Setting the enable bit (EN) in the enable RCU register (EDRAM, offset e4h) configures the mcs3_n/rfsh_n as rfsh_n.
- Bits [5–3]—Reserved → Set to 1.
- Bit [2]—R2 → Ready Mode. When set to 1, the external ready is ignored. When 0, it is required. The value of R1–R0 bits determines the number of wait states inserted.
- Bits [1–0]—R1–R0 → Wait-State Value. The value of these bits determines the number of wait states inserted into an access to the lcs_n memory area. This number ranges from 0 to 3 (R1–R0 = 00b to 11b).

5.1.18 UMCS (0a0h)

The Upper Memory Chip Select Register configures the UMCS pin, used for the top of memory. On reset, the first fetch takes place at memory location FFFF0h and thus this area of memory is usually used for instruction memory. The ucs_n defaults to an active state at reset with a memory range of 64 Kbytes (F0000h to FFFFFh), external ready required, and three wait states automatically inserted. The upper end of the memory range always ends at FFFFFh. The lower end of this upper memory range is programmable. The value of the UMCS register is F03Bh at reset (see Table 34).

Table 34. Upper-Memory Chip Select Register

15	14	13	12	11	10	9	8	7	6	5	4	3	2	1	0
1	LB2–LB0			Reserved			DA	0	Reserved			R2	R1–R0		

- Bit [15]—Reserved → Set to 1.
- Bits [14–12]—LB2–LB0 Lower Boundary → These bits determine the bottom of the memory accessed by the ucs_n chip selects. The UMCS Block-Size Programming Values shown below list the possible block-size configurations (a 512-Kbyte maximum).

UMCS Block-Size Programming Values

Memory Block Size	Starting Address	LB2–LB0	Comments
64K	F0000h	111b	Default
128K	E0000h	110b	–
256K	C0000h	100b	–
512K	80000h	000b	–

- Bits [11–8]—Reserved.
- Bit [7]—DA → Disable Address. When set to 1, the address bus is disabled and the address is not driven on the address bus when ucs_n is asserted, providing some measure of power saving. When 0, the address is driven onto the address bus (ad15–ad0) during the address phase of a bus cycle when ucs_n is asserted. This bit is set to 0 at reset.
 - If bhe_n/aden_n (IA186EM) is held at 0 during the rising edge of res_n, the address bus is always driven, regardless of the setting.
- Bit [6]—Reserved → Set to 0.
- Bits [5–3]—Reserved → Set to 1.
- Bit [2]—R2 Ready Mode → When set to 1, the external ready is ignored. When 0, it is required. The value of the R1–R0 bits determines the number of wait states inserted.
- Bits [1–0]—R1–R0 Wait-State Value → The value of these bits determines the number of wait states inserted into an access to the lcs_n memory area. This number ranges from 0 to 3 (R1–R0 = 00b to 11b).

5.1.19 SPBAUD (088h)

Serial Port BAUD Rate Divisor Register. The value in this register determines the number of internal processor cycles in one phase (half-period) of the 32 x serial clock. The contents of

these registers must be adjusted to reflect the new processor clock frequency if power-save mode is in effect. The baud rate divisor may be calculated from:

$$\text{BAUDDIV} = (\text{Processor Frequency}/(32 \times \text{baud rate})) - 1 \quad (\text{Equation 1})$$

By setting the BAUDDIV to 0000h, the maximum baud rate of 1/32 of the internal processor frequency clock is set. Setting BAUDDIV to 129 (81h) provides a baud rate of 9600 at 40 MHz. The baud rate tolerance is +4.6% to -1.9% with respect to the actual serial port baud rate, not the target baud rate (see Table 35).

Table 35. Baud Rates

Baud Rate	Divisor Based on CPU Clock Rate			
	20 MHz	25 MHz	33 MHz	40 MHz
300	4166	5208	6875	8333
600	2083	2604	3437	4166
1200	1041	1302	1718	2083
2400	520	651	859	1041
4800	260	325	429	520
9600	130	162	214	260
14400	42	53	71	85
19200	31	39	53	64
625 Kbaud	0	NA	NA	1
781.25 Kbaud	NA	0	NA	NA
1.041 Mbaud	NA	NA	0	NA
1.25 Mbaud	NA	NA	NA	0

The value of the SPBAUD register at reset is undefined (see Table 36).

Table 36. Serial Port Baud Rate Divisor Registers

15	14	13	12	11	10	9	8	7	6	5	4	3	2	1	0
BAUDDIV															

- Bits [15–0]—BAUDDIV Baud Rate Divisor → Defines the divisor for the internal processor clock.

5.1.20 SPRD (086h)

Serial Port Receive Data Register. Data received over the serial port are stored in this register until read. The data are received initially by the receive shift register (no software access) permitting data to be received while the previous data are being read.

The RDR bit (Receive Data Ready) in the serial port status register indicates the status of the SPRD register. Setting the RDR bit to 1 indicates there is valid data in the receive register. The value of the SPRD register is undefined at reset (see Table 37).

Table 37. Serial Port Receive Data Register

15	14	13	12	11	10	9	8	7	6	5	4	3	2	1	0
Reserved								RDATA							

- Bits [15–8]—Reserved.
- Bits [7–0]—RDATA → Holds valid data while the RDR bit of the status register is set.

5.1.21 SPTD (084h)

Serial Port Transmit Data Register. Data is written to this register by software, with the values to be transmitted by the serial port. Double buffering of the transmitter allows for the transmission of data from the transmit shift register (no software access) while the next data are written into the transmit register.

The THRE bit in the Serial Port Status register indicates whether there is valid data in the SPDT register. The THRE bit must be a 1 before writing data to this register to prevent overwriting valid data that is already in the SPDT register. The value of the SPTD register is undefined at reset (see Table 38).

Table 38. Serial Port Transmit Data Register

15	14	13	12	11	10	9	8	7	6	5	4	3	2	1	0
Reserved								TDATA							

- Bits [15–8]—Reserved.
- Bits [7–0]—TDATA → Holds the data to be transmitted.

5.1.22 SPSTS (082h)

Serial Port STatus Register. This register stores information concerning the current status of the port. The status bits are described below.

The value of the SPSTS register is undefined at reset (see Table 39).

Table 39. Serial Port Status Register

15	14	13	12	11	10	9	8	7	6	5	4	3	2	1	0
Reserved									TEMT	THRE	RDR	BRKI	FER	PER	OER

- Bits [15–7]—Reserved → Set to 0.
- Bit [6]—TEMT Transmitter Empty → When both the transmit shift register and the transmit register are empty, this bit is set indicating to software that it is safe to disable the transmitter. This bit is read-only.

- Bit [5]—THRE Transmit Holding Register Empty → When this bit is 1, the corresponding transmit holding register is ready to accept data. This is a read-only bit.
- Bit [4]—RDR Receive Data Ready → When this bit is 1, the respective SPRD register contains valid data. This is a read/write bit and can be reset only by reading the corresponding receive register.
- Bit [3]—BRKI Break Interrupt → This bit indicates that a break has been received when this bit is set to 1 and causes a serial port interrupt request.

Note: This bit should be reset by software.

- Bit [2]—FER Framing Error Detected → When the receiver samples the rxd line as low when a stop bit is expected (line high) a framing error is generated setting this bit.

Note: This bit should be reset by software.

- Bit [1]—PER Parity Error Detected → When a parity error is detected in either mode 1 or 3, this bit is set.

Note: This bit should be reset by software.

- Bit [0]—OER Overrun Error Detected → When new data overwrites valid data in the receive register (because it has not been read) an overrun error is detected setting this bit.

Note: This bit should be reset by software.

5.1.23 SPCT (080h)

Serial Port Control Register. This register controls both transmit and receive parts of the serial port. The value of the SPCT register is 0000h at reset (see Table 40).

Table 40. Serial Port Control Register

15	14	13	12	11	10	9	8	7	6	5	4	3	2	1	0
Reserved				TXIE	RXIE	LOOP	BRK	BRKVAL	PMODE	WLGN	STP	TMODE	RSIE	RMODE	

- Bits [15–12]—Reserved → Set to 0.
- Bit [11]—TXIE Transmitter Ready Interrupt Enable → This bit enables the generation of an interrupt request whenever the transmit holding register is empty (THRE Bit [1]). The respective port does not generate interrupts when this bit is 0. Interrupts continue to be generated as long as THRE and the TXIE are 1.

- Bit [10]—RXIE Receive Data Ready Interrupt Enable → This bit enables the generation of an interrupt request whenever the receive register contains valid data (RDR Bit [1]). The respective port does not generate interrupts when this bit is 0. Interrupts continue to be generated as long as RDR and the RXIE are 1.
- Bit [9]—LOOP Loop Back → The serial port is placed into the loop-back mode when this bit is set.
- Bit [8]—BRK Send Break → When this bit is set to 1, the txd pin is driven low, overriding any data that may be in the course of being shifted out of the transmit shift register.

Note: See the definitions of long and short break in Section 5.1.2, SPSTS (Serial Port Status Register).

- Bit [7]—BRKVAL Break Value → This is the ninth data bit transmitted when in modes 2 and 3. This bit is cleared at each transmitted word and is not buffered. To transmit data with this bit set high, the following procedure is recommended.
 1. The TEMT bit in the serial port status register must go high.
 2. Set the TB8 bit by writing it to the serial port control register.
 3. Write the transmit character to the serial port transmit register.
 - Serial port 0 is a special case. If this bit is 1, the associated pins are used for flow control overriding the Peripheral Chip Select signals. This bit is 0 at reset.
- Bits [6–5]—PMODE Parity Mode → When this bit is set to 1, the txd pin is driven low, overriding any data that may be in the course of being shifted out of the transmit shift register.

Note: See the definitions of long and short break in Section 5.1.2, SPSTS (Serial Port Status Register).

- Bit [4]—WLGN Word Length → The number of bits transmitted or received in a frame is determined by the value of this bit. When this bit is 1, the number of data bits in a frame is 8. When 0, it is 7. This bit is 0 at reset.
- Bit [3]—STP Stop Bits → This bit specifies the number of stop bits used to indicate the end of a frame. When this bit is 1, the number of stop bits is 2. When 0, it is 1. This bit is 0 at reset.
- Bit [2]—TMODE Transmit Mode → When this bit is 1, the transmit section of the serial port is enabled. When 0, it is disabled.

- Bit [1]—RSIE Receive Status Interrupt Enable → When an exception occurs during data reception, an interrupt request is generated if enabled by this bit (RSIE = 1). Interrupt requests are made for the error conditions listed in the serial port status register (BRK, OER, PER, and FER). This bit is 0 at reset.
- Bit [0]—RMODE Receive Mode → When this bit is 1, the receive section of the serial port is enabled. When 0, it is disabled. This bit is 0 at reset.

5.1.24 PDATA1 (07ah) and PDATA0 (074h)

PIO DATA Registers. When a PIO pin is configured as an output, the value in the corresponding PIO data register bit is driven onto the pin. However, if the PIO pin is configured as an input, the value on the pin is put into the corresponding bit of the PIO data register.

Table 41 lists the default states for the PIO pins.

Table 41. PIO Pin Assignments

PIO Number	Associated Pin Name	Power-On Reset Status
0	tmrin1	Input with pull-up
1	tmrout1	Input with pull-down
2	pcs6/a2	Input with pull-up
3	pcs5/a1	Input with pull-up
4	dt/r_n	Normal operation ^a
5	den_n/ds_n	Normal operation ^a
6	srdy	Normal operation ^b
7 ^c	a17	Normal operation ^a
8 ^c	a18	Normal operation ^a
9 ^c	a19	Normal operation ^a
10	tmrout0	Input with pull-down
11	tmrin0	Input with pull-up
12	drq0	Input with pull-up
13	drq1	Input with pull-up
14	mcs0_n	Input with pull-up
15	mcs1_n	Input with pull-up
16	pcs0_n	Input with pull-up
17	pcs1_n	Input with pull-up
18	pcs2_n	Input with pull-up
19	pcs3_n	Input with pull-up
20	sclk	Input with pull-up
21	sdata	Input with pull-up
22	sden0	Input with pull-down
23	sden1	Input with pull-down

Table 41. PIO Pin Assignments (Continued)

PIO Number	Associated Pin Name	Power-On Reset Status
24	mcs2_n	Input with pull-up
25	mcs3_n/rfsh_n	Input with pull-up
26 ^{c,d}	uzi	Input with pull-up
27	txd	Input with pull-up
28	rxid	Input with pull-up
29 ^{c,d}	s6/clkdir2_n	Input with pull-up
30	int4	Input with pull-up
31	int2	Input with pull-up

^aWhen used as a PIO pin, it is an input with a pull-up option available.

^bWhen used as a PIO pin, it is an input with a pull-down option available.

^cEmulators use these pins and also a15–a0, ad15–ad0 (IA186EM), ale, bhe_n (IA186EM), clkouta, nmi, res_n, and s2_n–s0_n.

^dIf bhe_n/aden_n (IA186EM) or rfsh2_n/aden (IA188EM) is held low during POR, these pins revert to normal operation.

The value of the PDATA registers is undefined at reset (see Tables 42 and 43).

Table 42. PDATA 0

15	14	13	12	11	10	9	8	7	6	5	4	3	2	1	0
PDATA15–PDATA0															

Table 43. PDATA 1

15	14	13	12	11	10	9	8	7	6	5	4	3	2	1	0
PDATA31–PDATA16															

- Bits [15–0]—PDATA15–PDATA0 PIO Data 0 Bits → This register contains the values of the bits that are either driven on, or received from, the corresponding PIO pins. Depending on its configuration, each pin is either an output or an input. The values of these bits correspond to those in the PIO Direction registers and PIO Mode registers.
- Bits [15–0]—PDATA31–PDATA16 PIO Data 1 Bits → This register contains the values of the bits that are either driven on, or received from, the corresponding PIO pins. Depending on its configuration, each pin is either an output or an input. The values of these bits correspond to those in the PIO direction registers and PIO Mode registers
- The PIO pins may be operated as open-drain outputs by:
 - Maintaining the data constant in the appropriate bit of the PIO data register.
 - Writing the value of the data bit into the respective bit position of the PIO Direction register, so that the output is either 0 or disabled depending on the value of the data bit.

5.1.25 PDIR1 (078h) and PDIR0 (072h)

PIO DIRection Registers. Each PIO pin is configured as an input or an output by the corresponding bit in the PIO Direction register (see Table 44).

Table 44. PIO Mode and PIO Direction Settings

PIO Mode	PIO Direction	Pin function
0	0	Normal operation
0	1	PIO input with pullup/pulldown
1	0	PIO output
1	1	PIO input without pullup/pulldown

The value of the PDIR0 register is FC0Fh at reset (see Table 45).

Table 45. PDIR0

15	14	13	12	11	10	9	8	7	6	5	4	3	2	1	0
PDIR15–PDIR0															

The value of the PDIR1 register is FFFFh at reset (see Table 46).

Table 46. PDIR1

15	14	13	12	11	10	9	8	7	6	5	4	3	2	1	0
PDIR31–PDIR16															

- Bits [15–0]—PDIR15–PDIR0 PIO Direction 0 Bits → For each bit, if the value is 1, the pin is configured as an input. If 0, as an output. The values of these bits correspond to those in the PIO data registers and PIO mode registers.
- Bits [15–0]—PDIR31–PDIR16 PIO Direction 1 Bits → For each bit, if the value is 1, the pin is configured as an input. If 0, as an output. The values of these bits correspond to those in the PIO Data registers and PIO Mode registers.

5.1.26 PIOMODE1 (076h) and PIOMODE0 (070h)

PIO MODE Registers. Each PIO pin is configured as an input or an output by the corresponding bit in the PIO direction register. The bit number of PMODE corresponds to the PIO number (see [Table 44, PIO Mode and PIO Direction Settings](#)). The value of the PIOMODE0 register is 0000h at reset (see Table 47).

Table 47. PIOMODE0

15	14	13	12	11	10	9	8	7	6	5	4	3	2	1	0
PMODE15–PMODE0															

The value of the PIOMODE1 register is 0000h at reset (see Table 48).

Table 48. PMODE1

15	14	13	12	11	10	9	8	7	6	5	4	3	2	1	0
PMODE31–PMODE16															

- Bits [15–0]—PMODE15–PMODE0 PIO Mode 0 Bits → For each bit, if the value is 1, the pin is configured as an input. If 0, an output. The values of these bits correspond to those in the PIO data registers and PIO Mode registers.
- Bits [15–0]—PMODE31–PMODE16 PIO Mode 1 Bits → For each bit, if the value is 1, the pin is configured as an input. If 0, an output. The values of these bits correspond to those in the PIO data registers and PIO Mode registers.

5.1.27 T1CON (05eh) and T0CON (056h)

Timer 0 and Timer 1 Mode and CONTROL Registers. These registers control the operation of Timer 0 and Timer 1, respectively. The value of the T0CON and T1CON registers is 0000h at reset (see Table 49).

Table 49. Timer 0 and Timer 1 Mode and Control Registers

15	14	13	12	11	10	9	8	7	6	5	4	3	2	1	0
EN	INHn	INT	RIU	Reserved						MC	RTG	P	EXT	ALT	CONT

- Bit [15]—EN Enable Bit → The timer is enabled when the EN bit is 1. The timer count is inhibited when the EN bit is 0. This bit is write-only and can only be written if the INHn bit (Bit [14]) is set to 1 in the same operation.
- Bit [14]—INHn Inhibit Bit → Gates the setting of the enable (EN) bit. This bit must be set to 1 in the same write operation that sets the enable (EN) bit. Otherwise, the EN bit will not be changed. This bit always reads 0.
- Bit [13]—INT Interrupt Bit → An interrupt request is generated when the Count register reaches its maximum, MC = 1, by setting the INT bit to 1. In dual maxcount mode, an interrupt request is generated when the count register reaches the value in Maxcount A or Maxcount B. No interrupt requests are generated if this bit is set to 0. If an interrupt request is generated, and the enable bit is then cleared before the interrupt is serviced, the interrupt request will remain.
- Bit [12]—RIU Register in Use Bit → This bit is set to 1 when the Maxcount Register B is used to compare to the timer-count value. It is 0 when the Maxcount Compare A register is used.

- Bits [11–6]—Reserved → Set to 0.
- Bit [5]—MC Maximum Count → When the timer reaches its maximum count, this bit is set to 1 regardless of the interrupt enable bit. This bit is also set every time Maxcount Compare Register A or B is reached when in dual maxcount mode. If preferred, this bit may be used by software polling rather than by interrupts to monitor timer status.
- Bit [4]—RTG Retrigger Bit → This pin controls the timer function of the timer input pin. When set to 1, the count is reset by a 0 to 1 transition on timrin0 or tmrin1. When 0, a high input on tmrin0 or tmrin1 enables the count and a 1 holds the timer value. This bit is ignored if the external clocking (EXT = 1) bit is set.
- Bit [3]—P Prescaler Bit → P is ignored if external clocking is enabled (EXT = 1). Timer 2 prescales the timer when P is set to 1. Otherwise, the timer is incremented on every fourth clkout cycle.
- Bit [2]—EXT External Clock Bit → This bit determines whether an external or internal clock is used. If EXT is 1, an external clock is used. If 0, an internal is used.
- Bit [1]—ALT Alternate Compare Bit → If set to 1, the timer will count to Maxcount Compare A, reset the count register to 0, count to Maxcount Compare B, reset the count register to 0, and begin again at Maxcount Compare A. If 0, it will count to Maxcount Compare A, reset the count register to 0, and begin again at Maxcount Compare A. Maxcount Compare B is not used in this case.
- Bit [0]—CONT Continuous Mode Bit → When set to 1, the timer runs continuously. When 0, the timer stops after each count run and EN will be cleared. If CONT = 1 and ALT = 1, the respective timer counts to the Maxcount Compare A value and resets, then commences counting to Maxcount Compare B value, resets, and stops counting.

5.1.28 T2CON (066h)

Timer 2 Mode and CONtrol Register. This register controls the operation of Timer 2. The value of the T2CON register is 0000h at reset (see Table 50).

Table 50. Timer 2 Mode and Control Registers

15	14	13	12	11	10	9	8	7	6	5	4	3	2	1	0
EN	INHn	INT	Reserved						MC	Reserved			CONT		

- Bit [15]—EN Enable Bit → The timer is enabled when the EN bit is 1. The timer count is inhibited when the EN bit is 0. Setting this bit to 1 by writing to the T2CON register requires that the INH bit be set to 1 during the same write. This bit is write-only and can only be written if the INHn bit (Bit [14]) is set to 1 in the same operation.

- Bit [14]—INHn Inhibit Bit → Gates the setting of the enable (EN) bit. This bit must be set to 1 in the same write operation that sets the enable (EN) bit. This bit always reads 0.
- Bit [13]—INT Interrupt Bit → An interrupt request is generated, by setting the INT bit to 1, when the Count register reaches its maximum, MC = 1.
- Bits [12–6]—Reserved → Set to 0.
- Bit [5]—MC Maximum Count → When the timer reaches its maximum count, this bit is set to 1, regardless of the interrupt enable bit. If preferred, this bit may be used by software polling rather than by interrupts to monitor timer status.
- Bits [4–1]—Reserved → Set to 0.
- Bit [0]—CONT Continuous Mode Bit → The timer will run continuously when this bit is set to 1. The timer will stop after each count run and EN will be cleared if this bit is set to 0.

5.1.29 T2COMPA (062h), T1COMPB (05ch), T1COMPA (05ah), T0COMPB (054h), and T0COMPA (052h)

Timer Maxcount COMPare Registers. These registers contain the maximum count value that is compared to the respective count register. Timer 0 and Timer 1 each have two compare registers.

If Timer 0 and/or Timer 1 is/are configured to count and compare first to Register A and then Register B, the tmrout0 or tmrout1 signals can be used to generate various duty-cycle wave forms.

Timer 2 has only one compare register, T2COMPA.

If one of these timer maxcount compare registers is set to 0000h, the respective timer will count from 0000h to FFFFh before generating an interrupt request. For example, a timer configured in this manner with a 40-MHz clock will interrupt every 6.5536 mS.

The value of these registers is undefined at reset (see Table 51).

Table 51. Timer Maxcount Compare Registers

15	14	13	12	11	10	9	8	7	6	5	4	3	2	1	0
TC15–TC0															

- Bits [15–0]—TC15–TC0 Timer Compare Value → The timer will count to the value in the respective register before resetting the count value to 0.

5.1.30 T2CNT (060h), T1CNT (058h), and T0CNT (050h)

These registers are incremented by one every four internal clock cycles if the relevant timer is enabled.

The Increment of Timer 0 and Timer 1 may also be controlled by external signals tmrin0 and tmrin1 respectively, or prescaled by Timer 2.

Comparisons are made between the count registers and maxcount registers and action taken dependent on achieving the maximum count.

The value of these registers is undefined at reset (see Table 52).

Table 52. Timer Count Registers

15	14	13	12	11	10	9	8	7	6	5	4	3	2	1	0
TC15–TC0															

- Bits [15–0]—TC15–TC0 Timer Count Value → This register has the value of the current count of the related timer that is incremented every fourth processor clock in internal clocked mode. Alternatively, the register is incremented each time the Timer 2 maxcount is reached if using Timer 2 as a prescaler. Timer 0 and Timer 1 may be externally clocked by tmrin0 and tmrin1 signals.

5.1.31 SPICON (044h) (Master Mode)

Serial Port Interrupt CONtrol Register. This register controls the operation of the asynchronous serial port interrupt source (SPI, Bit [10] in the Interrupt Request register). The value of this register is 001Fh at reset (see Table 53).

Table 53. Serial Port Interrupt Control Registers

15	14	13	12	11	10	9	8	7	6	5	4	3	2	1	0
Reserved											Reserved	MSK	PR2–PR0		

- Bits [15–5]—Reserved → Set to 0.
- Bit [4]—Reserved → Set to 1.
- Bit [3]—MSK Mask → This bit, when 0, enables the serial port to cause an interrupt. When this bit is 1, the serial port is prevented from generating an interrupt.
- Bits [2–0]—PR2–PR0 Priority → These bits define the priority of the serial port interrupt in relation to other interrupt signals. The interrupt priority is the lowest at 7 at reset. The values of PR2–PR0 are shown below.

Values of PR2–PR0 by Priority

Priority	PR2–PR0
(High) 0	000b
1	001b
2	010b
3	011b
4	100b
5	101b
6	110b
(Low) 7	111b

5.1.32 WDCON (044h) (Master Mode)

WatchDog Timer Interrupt CONTROL Register. These registers control the operation of the Watchdog Timer interrupt source. The value of this register is 000Fh at reset (see Table 54).

Table 54. Watchdog Timer Interrupt Control Register

15	14	13	12	11	10	9	8	7	6	5	4	3	2	1	0
Reserved											Reserved	MSK	PR2–PR0		

- Bits [15–5]—Reserved → Set to 0.
- Bit [4]—Reserved → Set to 0.
- Bit [3]—MSK Mask → This bit, when 0, enables the Watchdog Timer to cause an interrupt. When this bit is 1 prevents the Watchdog Timer from generating an interrupt.
- Bits [2–0]—PR2–PR0 Priority → These bits define the priority of the Watchdog Timer interrupt in relation to other interrupt signals. The interrupt priority is the lowest at 7 at reset. The values of PR2–PR0 are shown in the [above table](#).

5.1.33 I4CON (040h) (Master Mode)

This register controls the operation of the int4 signal, which is only intended for use in fully nested mode. The interrupt is assigned to type 10h. The value of the I4CON register is 000Fh at reset (see Table 55).

Table 55. INT4 Control Register

15	14	13	12	11	10	9	8	7	6	5	4	3	2	1	0
Reserved											LTM	MSK	PR2–PR0		

- Bits [15–5]—Reserved → Set to 0.
- Bit [4]—LTM Level-Triggered Mode → The int4 interrupt may be edge- or level-triggered, depending on the value of the bit. If LTM is 1, int4 is active high level-sensitive interrupt. If 0, it is a rising-edge triggered interrupt. The interrupt int4 must remain active (high) until serviced.
- Bit [3]—MSK Mask → The int4 signal can cause an interrupt if the MSK bit is 0. The int4 signal cannot cause an interrupt if the MSK bit is 1.
- Bits [2–0]—PR2–PR0 Priority → These bits define the priority of the serial port interrupt in relation to other interrupt signals. The interrupt priority is the lowest at 7 upon reset. The values of PR2–PR0 are shown in the [above table](#).

5.1.34 I3CON (03eh) and I2CON (03ch) (Master Mode)

INT2/INT3 CONTROL Register. The int2 and int3 are designated as interrupt type 0eh and 0fh, respectively, and may be configured as the interrupt acknowledge pins inta0_n and inta1_n in cascade mode. The value of these registers is 000Fh at reset (see Table 56).

Table 56. INT2/INT3 Control Register

15	14	13	12	11	10	9	8	7	6	5	4	3	2	1	0
Reserved											LTM	MSK	PR2–PR0		

- Bits [15–5]—Reserved → Set to 0.
- Bit [4]—LTM Level-Triggered Mode → The int2 or int3 interrupt may be edge- or level-triggered depending on the value of this bit. If LTM is 1, int2 or int3 is an active high level-sensitive interrupt. If 0, int2 or int3 is a rising-edge-triggered interrupt. The interrupt int2 or int3 must remain active (high) until acknowledged.
- Bit [3]—MSK Mask → The int2 or int3 signal can cause an interrupt if the MSK bit is 0. The int2 or int3 signal cannot cause an interrupt if the MSK bit is 1. The Interrupt Mask Register has a duplicate of this bit.
- Bits [2–0]—PR2–PR0 Priority → These bits define the priority of the serial port interrupt int2 or int3 in relation to other interrupt signals. The interrupt priority is the lowest at 7 at reset. The values of PR2–PR0 [are shown above](#).

5.1.35 I1CON (03ah) and I0CON (038h) (Master Mode)

INT0/INT1 CONTROL Register. The int0 and int1 are designated as interrupt type 0ch and 0dh, respectively, and may be configured as the interrupt acknowledge pins inta0 and inta1 in cascade mode. The value of these registers is 000Fh at reset (see Table 57).

Table 57. INT0/INT1 Control Register

15	14	13	12	11	10	9	8	7	6	5	4	3	2	1	0
Reserved									SFNM	C	LTM	MSK	PR2–PR0		

- Bits [15–7]—Reserved → Set to 0.
- Bit [6]—SFNM Special Fully Nested Mode → This bit enables fully nested mode for int0 or int1 when set to 1.
- Bit [5]—C Cascade Mode → This bit enables cascade mode for int0 or int1 when set to 1.
- Bit [4]—LTM Level-Triggered Mode → The int0 or int1 interrupt may be edge- or level-triggered depending on the value of the bit. If LTM is 1, int0 or int1 is an active high-level-sensitive interrupt. If 0, either is a rising-edge-triggered interrupt and must remain active (high) until acknowledged.
- Bit [3]—MSK Mask → The int0 or int1 signal can cause an interrupt if the MSK bit is 0. If it is 1, they cannot. The Interrupt Mask Register has a duplicate of this bit.
- Bits [2–0]—PR2–PR0 Priority → These bits define the priority of the serial port interrupt int0 or int1 in relation to other interrupt signals. The interrupt priority is the lowest at 7 at reset. The values of PR2–PR0 are shown above.

5.1.36 TCUCON (032h) (Master Mode)

Timer Control Unit Interrupt CONTROL Register. The three timers have their interrupts assigned to types 08h, 12h, and 13h and are configured by this register. The value of this register is 000Fh at reset (see Table 58).

Table 58. Timer Control Unit Interrupt Control Register

15	14	13	12	11	10	9	8	7	6	5	4	3	2	1	0
Reserved											MSK	PR2–PR0			

- Bits [15–4]—Reserved → Set to 0.
- Bit [3]—MSK Mask → An interrupt source may cause an interrupt if the MSK bit is 0. If 1, it cannot. The Interrupt Mask Register has a duplicate of this bit.
- Bits [2–0]—PR2–PR0 Priority → These bits define the priority of the serial port interrupt in relation to other interrupt signals. The interrupt priority is the lowest at 7 at reset. The values of PR2–PR0 are shown above.

5.1.37 T2INTCON (03ah), T1INTCON (038h), and T0INTCON (032h) (Slave Mode)

Timer INTerrupt CONtrol Register. The three timers, Timer 2, Timer 1, and Timer 0, each have an interrupt control register, whereas in master mode all three are masked and prioritized in one register (TCUCON). The value of these registers is 000Fh at reset (see Table 59).

Table 59. Timer Interrupt Control Register

15	14	13	12	11	10	9	8	7	6	5	4	3	2	1	0
Reserved												MSK	PR2–PR0		

- Bits [15–4]—Reserved → Set to 0.
- Bit [3]—MSK Mask → Any of the interrupt sources may cause an interrupt if the MSK bit is 0. If 1, they cannot. The Interrupt Mask Register has a duplicate of this bit.
- Bits [2–0]—PR2–PR0 Priority → These bits define the priority of the serial port interrupts in relation to other interrupt signals. The interrupt priority is the lowest at 7 at reset. The values of PR2–PR0 are shown above.

5.1.38 DMA1CON/INT6CON (036h) and DMA0CON/INT5CON (034h) (Master Mode)

DMA and INTerrupt CONtrol Register. The DMA0 and DMA1 interrupts have interrupt type 0ah and 0bh, respectively. These pins are configured as external interrupts or DMA requests in the respective DMA Control register. The value of these registers is 000Fh at reset (see Table 60).

Table 60. DMA and Interrupt Control Register (Master Mode)

15	14	13	12	11	10	9	8	7	6	5	4	3	2	1	0
Reserved												MSK	PR2–PR0		

- Bits [15–4]—Reserved → Set to 0.
- Bit [3]—MSK Mask → Any of the interrupt sources may cause an interrupt if the MSK bit is 0. If 1, they cannot. The Interrupt Mask Register has a duplicate of this bit.
- Bits [2–0]—PR2–PR0 Priority → These bits define the priority of the serial port interrupts in relation to other interrupt signals. The interrupt priority is the lowest at 7 at reset. The values of PR2–PR0 are shown above.

5.1.39 DMA1CON/INT6 (036h) and DMA0CON/INT5 (034h) (Slave Mode)

DMA and INTerrupt CONtrol Register. The two DMA control registers maintain their original functions and addressing that they possessed in Master Mode. These pins are configured as

external interrupts or DMA requests in the respective DMA Control register. The value of these registers is 000Fh at reset (see Table 61).

Table 61. DMA and Interrupt Control Register (Slave Mode)

15	14	13	12	11	10	9	8	7	6	5	4	3	2	1	0
Reserved												MSK	PR2–PR0		

- Bits [15–4]—Reserved → Set to 0.
- Bit [3]—MSK Mask → Any of the interrupt sources may cause an interrupt if the MSK bit is 0. If 1, they cannot. The Interrupt Mask Register has a duplicate of this bit.
- Bits [2–0]—PR2–PR0 Priority → These bits define the priority of the serial port interrupts in relation to other interrupt signals. The interrupt priority is the lowest at 7 at reset. The values of PR2–PR0 are shown above.

5.1.40 INTSTS (030h) (Master Mode)

INTerrupt STATuS Register. The Interrupt status register contains the interrupt request status of each of the three timers, Timer 2, Timer 1, and Timer 0 (see Table 62).

Table 62. Interrupt Status Register (Master Mode)

15	14	13	12	11	10	9	8	7	6	5	4	3	2	1	0
DHLT	Reserved											TMR2–TMR0			

- Bit [15]—DHLT DMA Halt → DMA activity is halted when this bit is 1. It is set to 1 automatically when any non-maskable interrupt occurs and is cleared to 0 when an IRET instruction is executed. Interrupt handlers and other time-critical software may modify this bit directly to disable DMA transfers. However, the DHLT bit should not be modified by software if the timer interrupts are enabled as the function of this register because an interrupt request register for the timers would be compromised.
- Bits [14–3]—Reserved.
- Bits [2–0]—TMR2–TMR0 Timer Interrupt Request → A pending interrupt request is indicated by the respective timer, when any of these bits is 1.

Note: The TMR bit in the REQST register is a logical OR of these timer interrupt requests.

5.1.41 INTSTS (030h) (Slave Mode)

When nonmaskable interrupts occur, the interrupt status register controls DMA operation and the interrupt request status of each of the three timers, Timer 2, Timer 1, and Timer 0 (see Table 63).

Table 63. Interrupt Status Register (Slave Mode)

15	14	13	12	11	10	9	8	7	6	5	4	3	2	1	0
DHLT	Reserved											TMR2–TMR0			

- Bit [15]—DHLT DMA Halt → DMA activity is halted when this bit is 1. It is set to 1 automatically when any non-maskable interrupt occurs and is cleared to 0 when an IRET instruction is executed.
- Bits [14–3]—Reserved.
- Bits [2–0]—TMR2–TMR0 Timer Interrupt Request → A pending interrupt request is indicated by the respective timer, when any of these bits is 1.

Note: The TMR bit in the REQST register is a logical OR of these timer interrupt requests.

5.1.42 REQST (02eh) (Master Mode)

Interrupt REQueST Register. This is a read-only register and such a read results in the status of the interrupt request bits presented to the interrupt controller. The REQST register is undefined on reset (see Table 64).

Table 64. Interrupt Request Register (Master Mode)

15	14	13	12	11	10	9	8	7	6	5	4	3	2	1	0
Reserved					SP0	WD	I4–I0				D1–D0	Reserved	TMR		

- Bits [15–11]—Reserved.
- Bit [10]—SP0 Serial Port 0 Interrupt Request → This is the serial port interrupt state and when enabled is the logical OR of all the serial port 0 interrupt sources, THRE, RDR, BRKI, FER, PER, and OER.
- Bit [9]—WD Watchdog Timer Interrupt Request → When it is a 1, the watchdog interrupt state indicates that an interrupt is pending.
- Bits [8–4]—I4–I0 Interrupt Requests → Setting any of these bits to 1 indicates that the relevant interrupt has a pending interrupt.
- Bits [3–2]—D1–D0 DMA Channel Interrupt Request → Setting either bit to 1 indicates that the respective DMA channel has a pending interrupt.
- Bit [1]—Reserved.

- Bit [0]—TMR Timer Interrupt Request → This is the timer interrupt state and is the logical OR of the timer interrupt requests. Setting this bit to 1 indicates that the timer control unit has a pending interrupt.

5.1.43 REQST (02eh) (Slave Mode)

This is a read-only register and such a read results in the status of the interrupt request bits presented to the interrupt controller. The status of these bits is available when this register is read.

When an internal interrupt request (D1, D0, TMR2, TMR1, or TMR0) occurs, the respective bit is set to 1. The internally generated interrupt acknowledge resets these bits. The REQST register contains 0000h on reset (see Table 65).

Table 65. Interrupt Request Register (Slave Mode)

15	14	13	12	11	10	9	8	7	6	5	4	3	2	1	0
Reserved										TMR2	TMR1	D1–D0	Reserved	TMR0	

- Bits [15–6]—Reserved.
- Bit [5]—TMR2 Interrupt Requests → Setting this bit to 1 indicates that Timer 2 has a pending interrupt.
- Bit [4]—TMR1 Interrupt Requests → Setting this bit to 1 indicates that Timer 1 has a pending interrupt.
- Bits [3–2]—D1–D0 DMA Channel Interrupt Request → Setting either bit to 1 indicates that the respective DMA channel has a pending interrupt.
- Bit [1]—Reserved.
- Bit [0]—TMR0 Timer Interrupt Request → Setting this bit to 1 indicates that Timer 0 has a pending interrupt.

5.1.44 INSERV (02ch) (Master Mode)

IN-SERVice Register. The interrupt controller sets the bits in this register when the interrupt is taken. Writing the corresponding interrupt type to the End-of-Interrupt (EOI) register clears each of these bits.

When one of these bits is set, an interrupt request will not be generated by the microcontroller for the respective source. This prevents an interrupt from interrupting itself if interrupts are enabled in the ISR. This restriction is bypassed in Special Fully nested mode for the int0 and int1 sources. The INSERV register contains 0000h on reset (see Table 66).

Table 66. In-Service Register (Master Mode)

15	14	13	12	11	10	9	8	7	6	5	4	3	2	1	0
Reserved					SPI	WD	I4-I0				D1-D0		Reserved	TMR	

- Bits [15–11]—Reserved.
- Bit [10]—SPI Serial Port Interrupt Request → This is the serial port 0 interrupt state.
- Bit [9]—WD Watchdog Timer Interrupt In-Service Request → This bit is the In-Service state of the Watchdog Timer.
- Bits [8–4]—I4–I0 Interrupt Requests → Setting any of these bits to 1 indicates that the relevant interrupt has a pending interrupt.
- Bits [3–2]—D1–D0 DMA Channel Interrupt In-Service → This bit is the In-Service state of the respective DMA channel.
- Bit [1]—Reserved.
- Bit [0]—TMR Timer Interrupt Request → This is the timer interrupt state and is the logical OR of the timer interrupt requests. Setting this bit to 1 indicates that the timer control unit has a pending interrupt.

5.1.45 INSERV (02ch) (Slave Mode)

This is a read-only register and such a read supplies the status of the interrupt request bits presented to the interrupt controller.

When an internal interrupt request (D1, D0, TMR2, TMR1, and TMR0) occurs, the respective bit is set to 1. The internally generated interrupt acknowledge resets these bits. The REQST register contains 0000h on reset (see Table 67).

Table 67. In-Service Register (Slave Mode)

15	14	13	12	11	10	9	8	7	6	5	4	3	2	1	0
Reserved										TMR2	TMR1	D1-D0		Reserved	TMR0

- Bits [15–6]—Reserved.
- Bit [5]—TMR2 Timer 2 Interrupt In Service → Timer 2 is being serviced when this bit is set to 1.
- Bit [4]—TMR1 Timer 1 Interrupt In Service → Timer 1 is being serviced when this bit is set to 1.

- Bits [3–2]—D1–D0 DMA Channel Interrupt In Service → The respective DMA channel is being serviced when this bit is set to 1.
- Bit [1]—Reserved.
- Bit [0]—TMR0 Timer Interrupt In Service → Timer 0 is being serviced when this bit is set to 1.

5.1.46 PRIMSK (02ah) (Master and Slave Mode)

PRiority MaSK Register. This register contains a value that sets the minimum priority level at which an interrupt can be generated by a maskable interrupt. The PRIMSK register contains 0007h on reset (see Table 68).

Table 68. Priority Mask Register

15	14	13	12	11	10	9	8	7	6	5	4	3	2	1	0
Reserved													PRM2–PRM0		

- Bits [15–3]—Reserved → Set to 0.
- Bits [2–0]—PRM2–PRM0 Priority Field Mask → This three-bit field sets the minimum priority necessary for a maskable interrupt to generate an interrupt. Any maskable interrupt with a numerically higher value than that contained by these three bits is masked. The values of PR2–PR0 are shown below.

Values of PR2–PR0 by Priority

Priority	PR2–PR0
(High) 0	000b
1	001b
2	010b
3	011b
4	100b
5	101b
6	110b
(Low) 7	111b

Any unmasked interrupt can generate an interrupt if the priority level is set to 7. On the other hand, if the priority level is set to say 4, only unmasked interrupts with a priority of 0 to 5 are permitted to generate interrupts.

5.1.47 IMASK (028h) (Master Mode)

Interrupt MASK Register. The interrupt mask register is read/write. Setting a bit in this register has the same effect as setting the MSK bit in the corresponding interrupt control register. Setting

a bit to 1 masks the interrupt. The interrupt request is enabled when the corresponding bit is set to 0. The IMASK register contains 07fdh on reset (see Table 69).

Table 69. Interrupt MASK Register (Master Mode)

15	14	13	12	11	10	9	8	7	6	5	4	3	2	1	0
Reserved					SPI	WD	I4–I0				D1–D0	Reserved	TMR		

- Bits [15–11]—Reserved.
- Bit [10]—SPI Serial Port Interrupt Mask → Setting this bit to 1 is an indication that the asynchronous serial port interrupt is masked.
- Bit [9]—WD Watchdog Timer Interrupt In-Service Request → Setting this bit to 1 indicates that the Watchdog Timer interrupt is masked.
- Bits [8–4]—I4–I0 Interrupt Mask → Setting any of these bits to 1 is an indication that the relevant interrupt is masked.
- Bits [3–2]—D1–D0 DMA Channel Interrupt Mask → Setting this bit to 1 is an indication that the respective DMA channel interrupt is masked.
- Bit [1]—Reserved.
- Bit [0]—TMR Timer Interrupt Mask → When set to 1, it indicates that the timer control unit interrupt is masked.

5.1.48 IMASK (028h) (Slave Mode)

Interrupt MASK Register. The interrupt mask register is read/write. Setting a bit in this register is effectively the same as setting the MSK bit in the corresponding interrupt control register. Setting a bit to 1 masks the interrupt request. The interrupt request is enabled when the corresponding bit is set to 0. The IMASK register contains 003dh on reset (see Table 70).

Table 70. Interrupt MASK Register (Slave Mode)

15	14	13	12	11	10	9	8	7	6	5	4	3	2	1	0
Reserved										TMR2	TMR1	D1–D0	Reserved	TMR0	

- Bits [15–6]—Reserved.
- Bit [5]—TMR2 Timer 2 Interrupt Mask → This bit provides an indication of the state of the mask bit in the Timer Interrupt Control register. When set to 1, it indicates that the interrupt request is masked.

- Bit [4]—TMR1 Timer 1 Interrupt Mask → This bit provides an indication of the state of the mask bit in the Timer Interrupt Control register. When set to 1, it indicates that the interrupt request is masked.
- Bits [3–2]—D1–D0 DMA Channel Interrupt Mask → This bit provides an indication of the state of the mask bit in the respective DMA channel Interrupt Control register. When set to 1, it indicates that the interrupt request is masked.
- Bit [1]—Reserved.
- Bit [0]—TMR0 Timer Interrupt Mask → This bit provides an indication of the state of the mask bit in the Timer Interrupt Control register. When set to 1, it indicates that the interrupt request is masked.

5.1.49 POLLST (026h) (Master Mode)

POLL Status Register. This register reflects the current state of the Poll register and can be read without affecting its contents. However, when the Poll Register is read, it causes the current interrupt to be acknowledged and replaced by the next interrupt. The poll status register is read-only (see Table 71).

Table 71. POLL Status Register

15	14	13	12	11	10	9	8	7	6	5	4	3	2	1	0
IREQ	Reserved										S4–S0				

- Bit [15]—IREQ Interrupt Request → This bit is set to 1 when an interrupt is pending. During this state the S4–S0 bits contain valid data.
- Bits [14–5]—Reserved.
- Bits [4–0]—S4–S0 Poll Status → These bits show the interrupt type of the highest priority pending interrupt.

The interrupt service routine does not begin execution automatically with the IS bit set. Rather, the application software must execute the appropriate ISR.

5.1.50 POLL (024h) (Master Mode)

POLL Register. When the Poll Register is read, it causes the current interrupt to be acknowledged and be replaced by the next interrupt. The poll status register reflects the current state of the Poll register and can be read without affecting its contents. The POLL register is read-only (see Table 72).

Table 72. Poll Register

15	14	13	12	11	10	9	8	7	6	5	4	3	2	1	0
IREQ	Reserved										S4–S0				

- Bit [15]—IREQ Interrupt Request → This bit is set to 1 when an interrupt is pending. During this state, the S4–S0 bits contain valid data.
- Bits [14–5]—Reserved.
- Bits [4–0]—S4–S0 Poll Status → These bits show the interrupt type of the highest priority pending interrupt.

5.1.51 EOI (022h) End-Of-Interrupt Register (Master Mode)

The In Service flags of the In-Service register are reset when a write is made to the EOI register. The interrupt service routine (ISR) should write to the EOI to reset the IS bit, in the In-Service register, for the interrupt before executing an IRET instruction that ends an interrupt service routine. Because it is most secure, the specific EOI reset is the preferred method for resetting the IS bits. The EOI register is write-only (see Table 73).

Table 73. End-of-Interrupt Register

15	14	13	12	11	10	9	8	7	6	5	4	3	2	1	0
NSPEC	Reserved										S4–S0				

- Bit [15]—NSPEQ Non-Specific EOI → When set to 1, this bit is a non-specific EOI. When 0, it indicates the specific EOI.
- Bits [14–5]—Reserved.
- Bits [4–0]—S4–S0 Source Interrupt Type → These bits show the interrupt type of the highest priority pending interrupt.

5.1.52 EOI (022h) Specific End-Of-Interrupt Register (Slave Mode)

Specific End-Of-Interrupt Register. An In-Service flag of a specific priority in the In-Service register, it is reset when a write is made to the EOI register. A three-bit user-supplied priority-level value that points to the in-service bit that is to be reset. Writing this value to this register resets the specific bit. The EOI register is write-only and undefined at reset (see Table 74).

Table 74. Specific End-of-Interrupt Register

15	14	13	12	11	10	9	8	7	6	5	4	3	2	1	0
Reserved												L2–L0			

- Bits [15–3]—Reserved → Write as 0.
- Bits [2–0]—L2–L0 Interrupt Type → The priority or the IS (interrupt service) bit to be reset is encoded in these three bits. Writing to these bits caused the issuance of an EOI for the interrupt type (see [Table 14, Interrupt Types](#)).

5.1.53 INTVEC (020h) Interrupt Vector Register (Slave Mode)

The CPU shifts left 2 bits (multiplies by 4) an 8-bit interrupt type, generated by the interrupt controller, to produce an offset into the interrupt vector table. The INTVEC register is undefined at reset (see [Table 75](#)).

Table 75. Interrupt Vector Register

15	14	13	12	11	10	9	8	7	6	5	4	3	2	1	0
Reserved								T4–T0				Reserved			

- Bits [15–8]—Reserved → Read as 0.
- Bits [7–3]—T4–T0 Interrupt Type → These five bits contain the five most significant bits of the interrupt types used for the internal interrupt type. The least significant three bits of the interrupt type are supplied by the interrupt controller, as set by the priority level of the interrupt request.
- Bits [2–0]—Reserved → Read as 0.

5.1.54 SSR (018h)

Synchronous Serial Receive Register. This register holds the serial data received on the SSI port. The value of the SSR register is undefined at reset (see [Table 76](#)).

Table 76. Synchronous Serial Receive Register

15	14	13	12	11	10	9	8	7	6	5	4	3	2	1	0
Reserved								SR7–SR0							

- Bits [15–8]—Reserved.
- Bits [7–0]—SR7–SR0 → Data received over the SDATA pin.

5.1.55 SSD0 (016h) and SSD0 (014h)

Synchronous Serial Transmit Registers. These registers hold the data to be transmitted by the SSI ports. The value of these registers is undefined at reset (see [Table 77](#)).

Table 77. Synchronous Serial Transmit Registers

15	14	13	12	11	10	9	8	7	6	5	4	3	2	1	0
Reserved								SD7–SD0							

- Bits [15–8]—Reserved.
- Bits [7–0]—SD7–SD0 → Data to be transmitted over the SDATA pin.

5.1.56 SSC (012h)

Synchronous Serial Control Register. This register controls the operation of the sden1 and sden0 outputs and the baud rate of the SSI port. The sden1 and sden0 outputs are held high when the respective bit is set to 1, but in the event that both DE1 and DE0 are set to 1 then only sden0 will be held high. The value of the SSR register is 0000h at reset (see Table 78).

Table 78. Synchronous Serial Control Registers

15	14	13	12	11	10	9	8	7	6	5	4	3	2	1	0
Reserved										SCLKDIV		Reserved		DE1	DE0

- Bits [15–6]—Reserved.
- Bits [5–4]—SCLKDIV SCLK Divide → These bits set the SCLK frequency. SCLK is the result of dividing the internal processor clock by 2, 4, 8, or 16 as shown below.

SCLKDIV	SCLK Frequency Divider
00b	Processor Clock/2
01b	Processor Clock/4
10b	Processor Clock/8
11b	Processor Clock/16

- Bits [3–2]—Reserved.
- Bit [1]—DE1 SDEN1 → The SDEN1 bit is held high when this bit is set to 1 and SDEN1 is held low when this bit is set to 0.
- Bit [0]—DE0 SDEN0 → The SDEN0 bit is held high when this bit is set to 1 and SDEN0 is held low when this bit is set to 0.

5.1.57 SSS (010h)

Synchronous Serial Status Register. This is a read-only register that indicates the state of the SSI port. The value of the SSR register is 0000h at reset (see Table 79).

Table 79. Synchronous Serial Status Registers

15	14	13	12	11	10	9	8	7	6	5	4	3	2	1	0
Reserved												RE/TE	DR/DT	PB	

- Bits [15–3]—Reserved.
- Bit [2]—RE/TE Receive/Transmit Error Detect → This bit is set to 1 when a read of the Synchronous Serial Received register or a write to one of the transmit register is detected while the interface is busy (PB = 1). This bit is reset to 0 when the SDEN output is not active (DE1–DE0 in the SSC register are 00h).
- Bit [1]—DR/DT Data Receive/Transmit Complete → This bit is set to a 1 when the transmission of data Bit [7] is completed (SCLK rising edge) during a transmit or receive operation. This bit is reset by a read of the SSR register, when either the SSD0 or SSD1 register is written, when the SSS register is read (unless the SSI completes an operation and sets the bit in the same cycle), or when both SDEN0 and SDEN1 become inactive.
- Bit [0]—PB SSI Port Busy → This bit indicates that a data transmit or receive is occurring when it is set to 1. When set to 0, it indicates that the port is ready to transmit or receive data.

5.2 Reference Documents

Additional information on the operation and programming of the IA186EM/ IA188EM can be found in the following Advanced Micro Devices (AMD) publications:

- *Am186™EM and Am188™EM Microcontrollers User’s Manual*, February 1997, Publication 19713.
- *Am186™EM/EMLV and Am188™EM/EMLV Preliminary Data Sheet*, February 1997, Publication 19168, Rev. E, Amendment 0.

6. AC Specifications

Table 80 presents the AC characteristics over commercial operating ranges (40 MHz). Tables 81 and 82 present the alphabetic and numeric keys to waveform parameters, respectively. Figure 11 presents the read cycle. Figure 12 presents the multiple read cycles. Table 83 presents the read cycle timing. Figure 13 presents the write cycle. Figure 14 presents the multiple write cycles. Table 84 presents the write cycle timing.

Figure 15 presents the PSRAM read cycle. Table 85 presents the PSRAM read cycle timing. Figure 16 presents the PSRAM write cycle. Table 86 presents the PSRAM write cycle timing. Figure 17 presents the PSRAM refresh cycle. Table 87 presents the PSRAM refresh cycle timing. Figure 18 presents the interrupt acknowledge cycle. Table 88 presents the interrupt

acknowledge cycle timing. Figure 19 presents the software halt cycle. Table 89 presents the software halt cycle timing. Figure 20 presents the clock—active mode. Figure 21 presents the clock—power-save mode. Table 90 presents the clock timing.

Figure 22 presents the *srdy*—synchronous ready. Figure 23 presents the *ardy*—asynchronous ready. Figure 24 presents the peripherals. Table 91 presents the ready and peripheral timing. Figures 25 and 26 present Reset 1 and Reset 2, respectively. Figures 27 and 28 present the bus hold entering and bus hold leaving, respectively. Table 92 presents the reset and bus hold timing.

Figure 29 presents the synchronous serial interface. Table 93 presents the synchronous serial interface timing.

Table 80. AC Characteristics Over Commercial Operating Ranges (40 MHz)

No.	Name	Description	Min	Max
General Timing Requirements				
1	tDVCL	Data in Setup	10	–
2	tCLDX	Data in Hold	0	–
General Timing Responses				
3	tCHSV	Status Active Delay	0	6
4	tCLSH	Status Inactive Delay	0	6
5	tCLAV	<i>ad</i> Address Valid Delay	0	12
6	tCLAX	Address Hold	0	12
8	tCHDX	Status Hold Time	0	–
9	tCHLH	<i>ale</i> Active Delay	0	8
10	tLHLL	<i>ale</i> Width	tCLCH-5	–
11	tCHLL	<i>ale</i> Inactive Delay	0	8
12	tAVLL	<i>ad</i> Address Valid to <i>ale</i> Low	tCLCH	–
13	tLLAX	<i>ad</i> Address Hold from <i>ale</i> Inactive	tCHCL	–
14	tAVCH	<i>ad</i> Address Valid to Clock High	0	–
15	tCLAZ	<i>ad</i> Address Float Delay	0	12
16	tCLCSV	<i>mcs_n/pcs_n</i> Inactive Delay	0	12
17	tCXCSX	<i>mcs_n/pcs_n</i> Hold from Command Inactive	tCLCH	–
18	tCHCSX	<i>mcs_n/pcs_n</i> Inactive Delay	0	12
19	tDXDL	<i>den_n</i> Inactive to <i>dt/r_n</i> Low	0	–
20	tCVCTV	Control Active Delay 1	0	10
21	tCVDEX	<i>den_n</i> Inactive Delay	0	0
22	tCHCTV	Control Active Delay 2	0	10
23	tLHAV	<i>ale</i> High to Address Valid	7.5	–
80	tCLCLX	<i>lcs_n</i> Inactive Delay	0	9
81	tCLCSL	<i>lcs_n</i> Active Delay	0	9
82	tCLRF	<i>clkouta</i> High to <i>rfs_n</i> Invalid	0	12
84	tLRL	<i>lcs_n</i> Precharge Pulse Width	tCLCL + tCLCH	–

Table 80. AC Characteristics Over Commercial Operating Ranges (40 MHz) (Continued)

No.	Name	Description	Min	Max
Read Cycle Timing Responses				
24	tAZRL	<i>ad</i> Address Float to rd_n Active	0	–
25	tCLRL	rd_n Active Delay	0	10
26	tRLRH	rd_n Pulse Width	tCLCL	–
27	tCLRH	rd_n Inactive Delay	0	10
28	tRHLH	rd_n Inactive to ale High	tCLCH	–
29	tRHAV	rd_n Inactive to <i>ad</i> Address Active	tCLCL	–
30	tCLDOX	Data Hold Time	0	–
Write Cycle Timing Responses				
31	tCVCTX	Control Inactive Delay	0	10
32	tWLWH	wr_n Pulse Width	2tCLCL	–
33	tWHLH	wr_n Inactive to ale High	tCLCH	–
34	tWHDX	Data Hold after wr_n	tCLCL	–
35	tWHDEX	wr_n Inactive to den_n Inactive	tCLCH	–
41	tDSHLH	ds_n Inactive to ale Inactive	tCLCH	–
59	tRHDX	rd_n High to Data Hold on <i>ad</i> Bus	0	–
65	tAVWL	<i>a</i> Address Valid to wr_n Low	tCLCL + tCHCL	–
66	tAVRL	<i>a</i> Address Valid to rd_n Low	tCLCL + tCHCL	–
67	tCHCSV	clkouta High to lcs_n/usc_n Valid	0	9
68	tCHAV	clkouta High to <i>a</i> Address Valid	0	8
87	tAVBL	<i>a</i> Address Valid to whb_n/wlb_n Low	tCHCL -1.5	tCHCL
Refresh Timing Cycle Parameters				
79	tCHRFD	clkouta High to rfsh_n Valid	0	12
82	tCLRF	clkouta High to rfsh_n Invalid	0	12
85	tRFCY	rfsh_n Cycle Time	6tCLCL	–
86	tLCRF	lcs_n Inactive to rfsh_n Active Delay	2tCLCL	–
ckin Timing				
36	tCKIN	x1 Period	25	66
37	tCLCK	x1 Low Time	7.5	–
38	tCHCK	x1 High Time	7.5	–
39	tCKHL	x1 Fall Time	–	5
40	tCKLH	x1 Rise time	–	5
clkout Timing				
42	tCLCL	clkouta Period	25	–
43	tCLCH	clkouta Low Time	TCLCL/2	–
44	tCHCL	clkouta High Time	TCLCL/2	–
45	tCH1CH2	clkouta Rise Time	–	3
46	tCL2CL1	clkouta Fall Time	–	3
61	tLOCK	Maximum PLL Lock Time	–	0.5
69	tCICOA	x1 to clkouta Skew	–	25
70	tCICOB	x1 to clkoutb Skew	–	35

Table 80. AC Characteristics Over Commercial Operating Ranges (40 MHz) (Continued)

No.	Name	Description	Min	Max
Ready and Peripheral Timing Requirements				
47	tSRYCL	sr _{dy} Transition Setup Time	10	–
48	tCLSR _Y	sr _{dy} Transition Hold Time	3	–
49	tARYCH	ard _y Resolution Transition Setup Time	9	–
50	tCLARX	ard _y Active Hold Time	4	–
51	tARYCHL	ard _y Inactive Holding Time	6	–
52	tARYLCL	ard _y Setup Time	9	–
53	tINVCH	Peripheral Setup Time	10	–
54	tINVCL	dr _q Setup Time	10	–
Peripheral Timing Responses				
55	tCLTMV	Timer Output Delay	0	12
Reset & Hold Timing Requirements				
57	tRESIN	res _n Setup Time	10	–
58	tHVCL	hld Setup Time	10	–
Reset and Hold Timing Responses				
62	tCLHAV	hlda Valid Delay	0	7
63	tCHCZ	Command Lines Float Delay	0	12
64	tCHCV	Command Lines Valid Delay (after Float)	0	12
Synchronous Serial Port Timing Requirements				
75	tDVSH	Data Valid to sclk High	10	–
77	tSHDX	sclk High to SPI Data Hold	3	–
Synchronous Serial Port Timing Responses				
71	tCLEV	clkout _a Low to sden Valid	0	12
72	tCLSL	clkout _a Low to sclk High	0	12
78	tSLDV	sclk Low to Data Valid	0	12

Table 81. Alphabetic Key to Waveform Parameters

No.	Name	Description
49	tARYCH	ardy Resolution Transition Setup Time
51	tARYCHL	ardy Inactive Holding Time
52	tARYLCL	ardy Setup Time
87	tAVBL	a Address Valid to whb_n/wlb_n Low
14	tAVCH	ad Address Valid to Clock High
12	tAVLL	ad Address Valid to ale Low
66	tAVRL	a Address Valid to rd_n Low
65	tAVWL	a Address Valid to wr_n Low
24	tAZRL	ad Address Float to rd_n Active
45	tCH1CH2	clkouta Rise Time
68	tCHAV	clkouta High to a Address Valid
38	tCHCK	x1 High Time
44	tCHCL	clkouta High Time
67	tCHCSV	clkouta High to lcs_n/usc_n Valid
18	tCHCSX	mcs_n/pcs_n Inactive Delay
22	tCHCTV	Control Active Delay 2
64	tCHCV	Command Lines Valid Delay (after Float)
63	tCHCZ	Command Lines Float Delay
8	tCHDX	Status Hold Time
9	tCHLH	ale Active Delay
11	tCHLL	ale Inactive Delay
79	tCHRFD	clkouta High to rfsh_n Valid
3	tCHSV	Status Active Delay
69	tCICOA	x1 to clkouta Skew
70	tCICOB	x1 to clkoutb Skew
39	tCKHL	x1 Fall Time
36	tCKIN	x1 Period
40	tCKLH	x1 Rise time
46	tCL2CL1	clkouta Fall Time
50	tCLARX	ardy Active Hold Time
5	tCLAV	ad Address Valid Delay
6	tCLAX	Address Hold
15	tCLAZ	ad Address Float Delay
43	tCLCH	clkouta Low Time
37	tCLCK	x1 Low Time
42	tCLCL	clkouta Period
80	tCLCLX	lcs_n Inactive Delay
81	tCLCSL	lcs_n Active Delay
16	tCLCSV	mcs_n/pcs_n Inactive Delay
30	tCLDOX	Data Hold Time

Table 81. Alphabetic Key to Waveform Parameters (Continued)

No.	Name	Description
7	tCLDV	Data Valid Delay
2	tCLDX	Data in Hold
71	tCLEV	clkouta Low to sden Valid
62	tCLHAV	hlda Valid Delay
82	tCLRF	clkouta High to rfsh_n Invalid
27	tCLRH	rd_n Inactive Delay
25	tCLRL	rd_n Active Delay
4	tCLSH	Status Inactive Delay
72	tCLSL	clkouta Low to sclk Low
48	tCLSRY	srdy Transition Hold Time
55	tCLTMV	Timer Output Delay
83	tCOAOB	clkouta to clkoutb Skew
20	tCVCTV	Control Active Delay 1
31	tCVCTX	Control Inactive Delay
21	tCVDEX	den_n Inactive Delay
17	tCXCSX	mcs_n/pcs_n Hold from Command Inactive
1	tDVCL	Data in Setup
75	tDVSH	Data Valid to SCLK High
19	tDXDL	den_n Inactive to dt/r_n Low
58	tHVCL	hld Setup Time
53	tINVCH	Peripheral Setup Time
54	tINVCL	drq Setup Time
86	tLCRF	lcs_n Inactive to rfsh_n Active Delay
23	tLHAV	ale High to Address Valid
10	tLHLL	ale Width
13	tLLAX	ad Address Hold from ALE Inactive
61	tLOCK	Maximum PLL Lock Time
84	tLRLL	lcs_n Precharge Pulse Width
57	tRESIN	res_n Setup Time
85	tRFCY	rfsh_n Cycle Time
29	tRHAV	rd_n Inactive to ad Address Active
59	tRHDX	rd_n High to Data Hold on ad Bus
28	tRHLH	rd_n Inactive to ale High
26	tRLRH	rd_n Pulse Width
77	tSHDX	sclk High to SPI Data Hold
78	tSLDV	sclk Low SPI Data Hold
47	tSRYCL	srdy Transition Setup Time
35	tWHDEX	wr_n Inactive to den_n Inactive
34	tWHDX	Data Hold after wr_n
33	tWHLH	wr_n Inactive to ale High
32	tWLWH	wr_n Pulse Width

Table 82. Numeric Key to Waveform Parameters

No.	Name	Description
1	tDVCL	Data in Setup
2	tCLDX	Data in Hold
3	tCHSV	Status Active Delay
4	tCLSH	Status Inactive Delay
5	tCLAV	<i>ad</i> Address Valid Delay
6	tCLAX	Address Hold
7	tCLDV	Data Valid Delay
8	tCHDX	Status Hold Time
9	tCHLH	<i>ale</i> Active Delay
10	tLHLL	<i>ale</i> Width
11	tCHLL	<i>ale</i> Inactive Delay
12	tAVLL	<i>ad</i> Address Valid to ALE Low
13	tLLAX	<i>ad</i> Address Hold from ALE Inactive
14	tAVCH	<i>ad</i> Address Valid to Clock High
15	tCLAZ	<i>ad</i> Address Float Delay
16	tCLCSV	<i>mcs_n/pcs_n</i> Inactive Delay
17	tXCXSX	<i>mcs_n/pcs_n</i> Hold from Command Inactive
18	tCHCSX	<i>mcs_n/pcs_n</i> Inactive Delay
19	tDXDL	<i>den_n</i> Inactive to <i>dt/r_n</i> Low
20	tCVCTV	Control Active Delay 1
21	tCVDEX	<i>den_n</i> Inactive Delay
22	tCHCTV	Control Active Delay 2
23	tLHAV	<i>ale</i> High to Address Valid
24	tAZRL	<i>ad</i> Address Float to <i>rd_n</i> Active
25	tCLRL	<i>rd_n</i> Active Delay
26	tRLRH	<i>rd_n</i> Pulse Width
27	tCLRH	<i>rd_n</i> Inactive Delay
28	tRHLH	<i>rd_n</i> Inactive to <i>ale</i> High
29	tRHAV	<i>rd_n</i> Inactive to <i>ad</i> Address Active
30	tCLDOX	Data Hold Time
31	tCVCTX	Control Inactive Delay
32	tWLWH	<i>wr_n</i> Pulse Width
33	tWHLH	<i>wr_n</i> Inactive to <i>ale</i> High
34	tWHDX	Data Hold after <i>wr_n</i>
35	tWHDEX	<i>wr_n</i> Inactive to <i>den_n</i> Inactive
36	tCKIN	<i>x1</i> Period
37	tCLCK	<i>x1</i> Low Time
38	tCHCK	<i>x1</i> High Time
39	tCKHL	<i>x1</i> Fall Time
40	tCKLH	<i>x1</i> Rise time

Table 82. Numeric Key to Waveform Parameters (Continued)

No.	Name	Description
42	tCLCL	clkouta Period
43	tCLCH	clkouta Low Time
44	tCHCL	clkouta High Time
45	tCH1CH2	clkouta Rise Time
46	tCL2CL1	clkouta Fall Time
47	tSRYCL	srDY Transition Setup Time
48	tCLSRy	srDY Transition Hold Time
49	tARyCH	ardY Resolution Transition Setup Time
50	tCLARX	ardY Active Hold Time
51	tARyCHL	ardY Inactive Holding Time
52	tARyLCL	ardY Setup Time
53	tINVCH	Peripheral Setup Time
54	tINVCL	drq Setup Time
55	tCLTMV	Timer Output Delay
57	tRESIN	res_n Setup Time
58	tHVCL	hld Setup Time
59	tRHDX	rd_n High to Data Hold on <i>ad</i> Bus
61	tLOCK	Maximum PLL Lock Time
62	tCLHAV	hlda Valid Delay
63	tCHCZ	Command Lines Float Delay
64	tCHCV	Command Lines Valid Delay (after Float)
65	tAVWL	<i>a</i> Address Valid to wr_n Low
66	tAVRL	<i>a</i> Address Valid to rd_n Low
67	tCHCSV	clkouta High to lcs_n/usc_n Valid
68	tCHAV	clkouta High to <i>a</i> Address Valid
69	tCICOA	x1 to clkouta Skew
70	tCICOB	x1 to clkoutb Skew
71	tCLEV	clkouta Low to sden Valid
72	tCLSL	clkouta Low to sclk High
75	tDVSH	Data Valid to sclk High
77	tSHDX	sclk High to SPI Data Hold
78	tSLDV	sclk Low to Data Valid
79	tCHRFD	clkouta High to rfsh_n Valid
80	tCLCLX	lcs_n Inactive Delay
81	tCLCSL	lcs_n Active Delay
82	tCLRF	clkouta High to rfsh_n Invalid
83	tCOAOB	clkouta to clkoutb Skew
84	tLRLl	lcs_n Precharge Pulse Width
85	tRFCY	rfsh_n Cycle Time
86	tLCRF	lcs_n Inactive to rfsh_n Active Delay
87	tAVBL	<i>a</i> Address Valid to whb_n/wlb_n Low

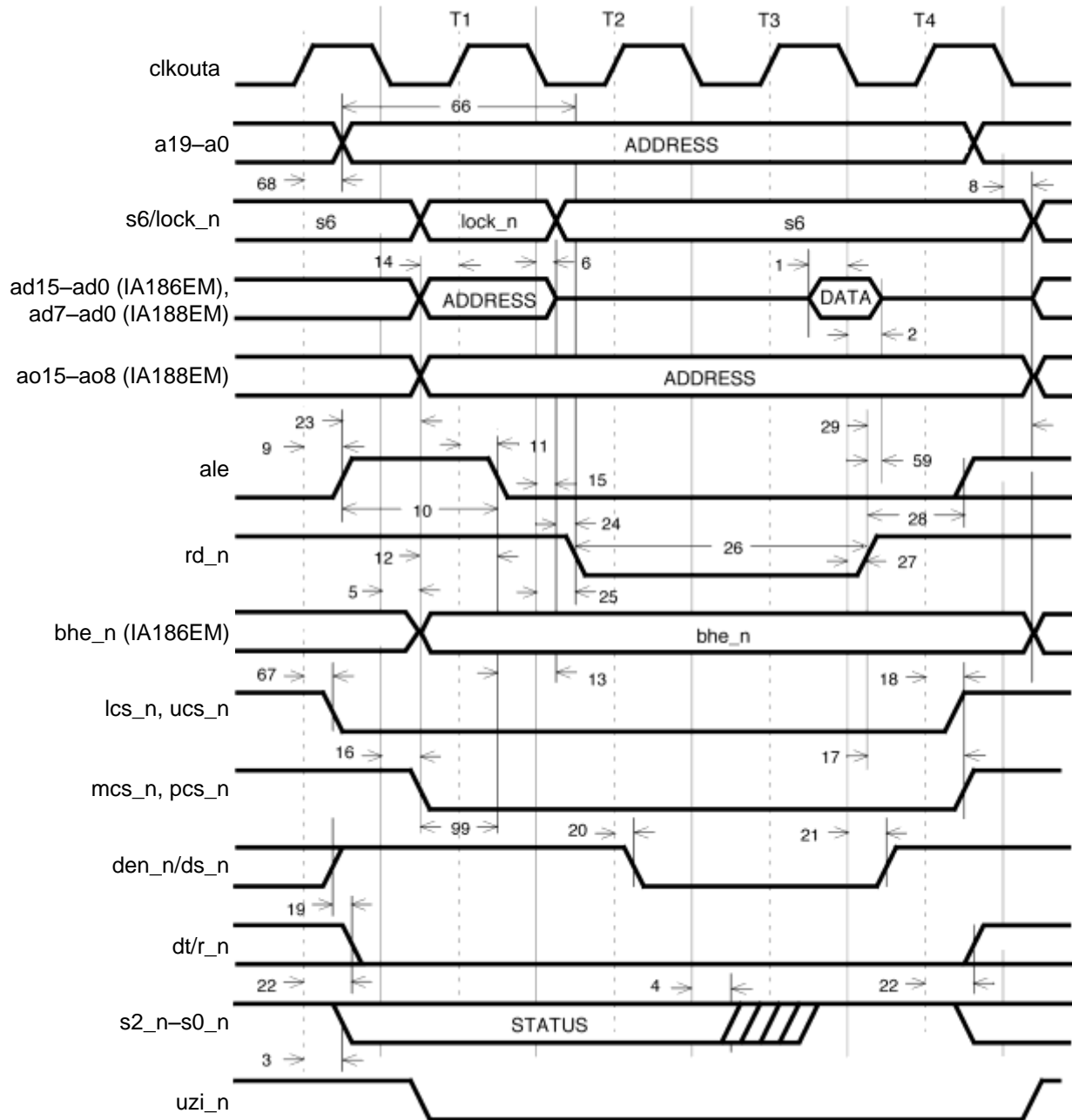

Figure 11. Read Cycle

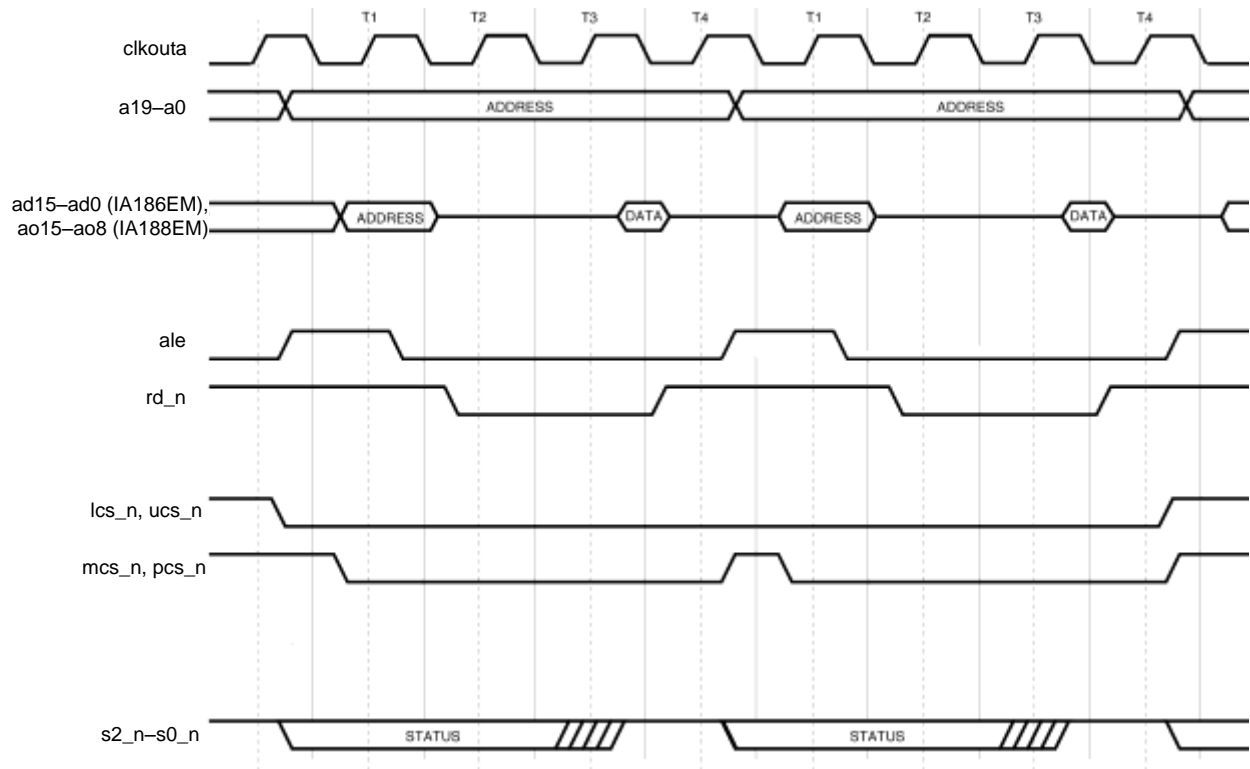

Figure 12. Multiple Read Cycles

Table 83. Read Cycle Timing

No.	Name	Description	Min ^a	Max ^a
General Timing Requirements				
1	tDVCL	Data in Setup	10	–
2	tCLDX	Data in Hold	0	–
General Timing Responses				
3	tCHSV	Status Active Delay	0	6
4	tCLSH	Status Inactive Delay	0	6
5	tCLAV	<i>ad</i> Address Valid Delay	0	12
6	tCLAX	Address Hold	0	12
8	tCHDX	Status Hold Time	0	–
9	tCHLH	<i>ale</i> Active Delay	0	8
10	tLHLL	<i>ale</i> Width	tCLCH-5	–
11	tCHLL	<i>ale</i> Inactive Delay	0	8
12	tAVLL	<i>ad</i> Address Valid to <i>ale</i> Low	tCLCH	–
13	tLLAX	<i>ad</i> Address Hold from <i>ale</i> Inactive	tCHCL	–
14	tAVCH	<i>ad</i> Address Valid to Clock High	0	–
15	tCLAZ	<i>ad</i> Address Float Delay	0	12
16	tCLCSV	<i>mcs_n/pcs_n</i> Inactive Delay	0	12
17	tCXCSX	<i>mcs_n/pcs_n</i> Hold from Command Inactive	tCLCH	–
18	tCHCSX	<i>mcs_n/pcs_n</i> Inactive Delay	0	12
19	tDXDL	<i>den_n</i> Inactive to <i>dt/r_n</i> Low	0	–
20	tCVCTV	Control Active Delay 1	0	10
21	tCVDEX	<i>den_n</i> Inactive Delay	0	9
22	tCHCTV	Control Active Delay 2	0	10
23	tLHAV	<i>ale</i> High to Address Valid	7.5	–
Read Cycle Timing Responses				
24	tAZRL	<i>ad</i> Address Float to <i>rd_n</i> Active	0	–
25	tCLRL	<i>rd_n</i> Active Delay	0	10
26	tRLRH	<i>rd_n</i> Pulse Width	tCLCL	–
27	tCLRH	<i>rd_n</i> Inactive Delay	0	10
28	tRHLH	<i>rd_n</i> Inactive to <i>ale</i> High	tCLCH	–
29	tRHAV	<i>rd_n</i> Inactive to <i>ad</i> Address Active	tCLCL	–
66	tAVRL	<i>a</i> Address Valid to <i>rd_n</i> Low	tCLCL + tCHCL	–
67	tCHCSV	<i>clkouta</i> High to <i>lcs_n/usc_n</i> Valid	0	9
68	tCHAV	<i>clkouta</i> High to <i>a</i> Address Valid	0	8

^aIn nanoseconds.

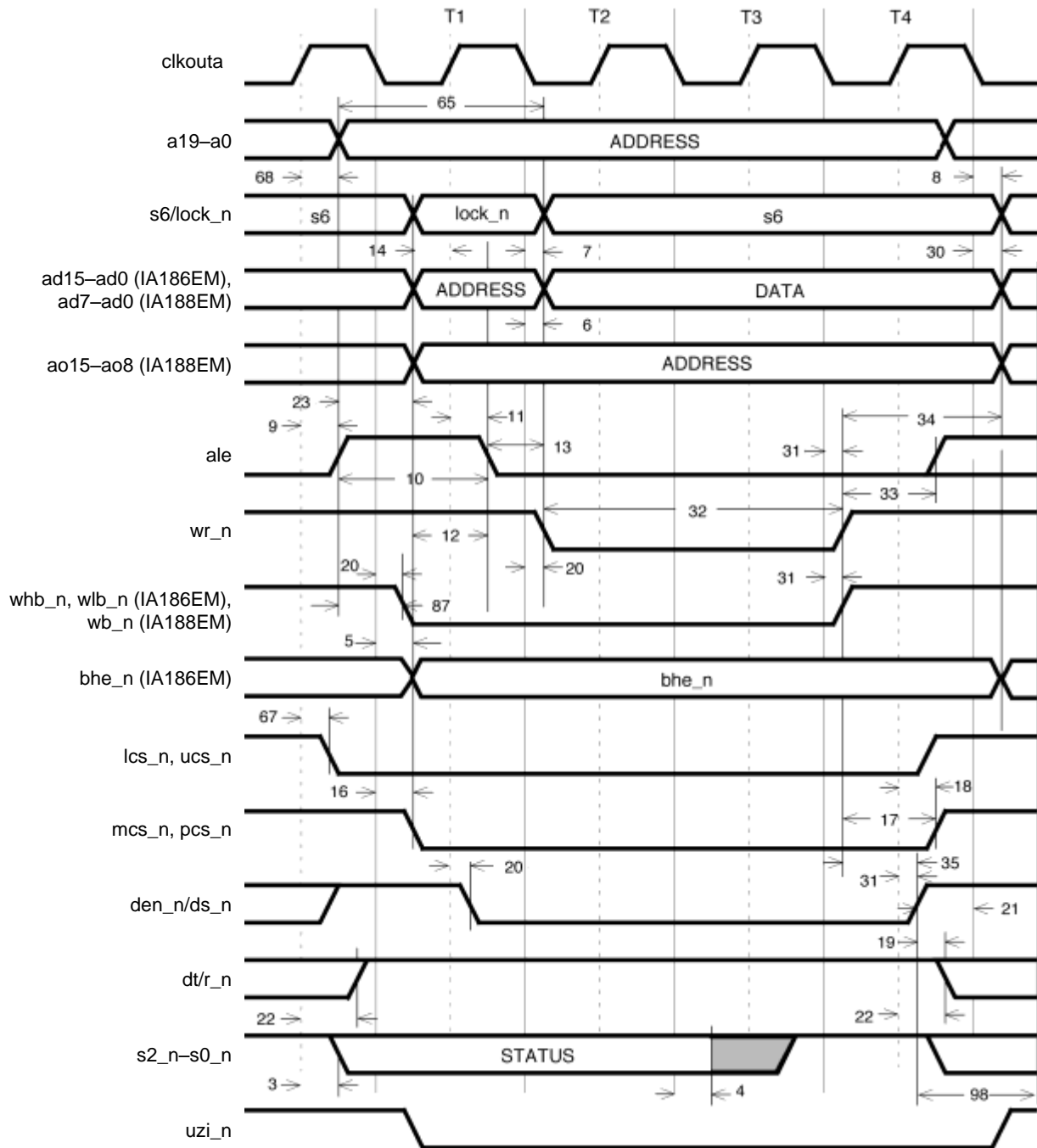

Figure 13. Write Cycle

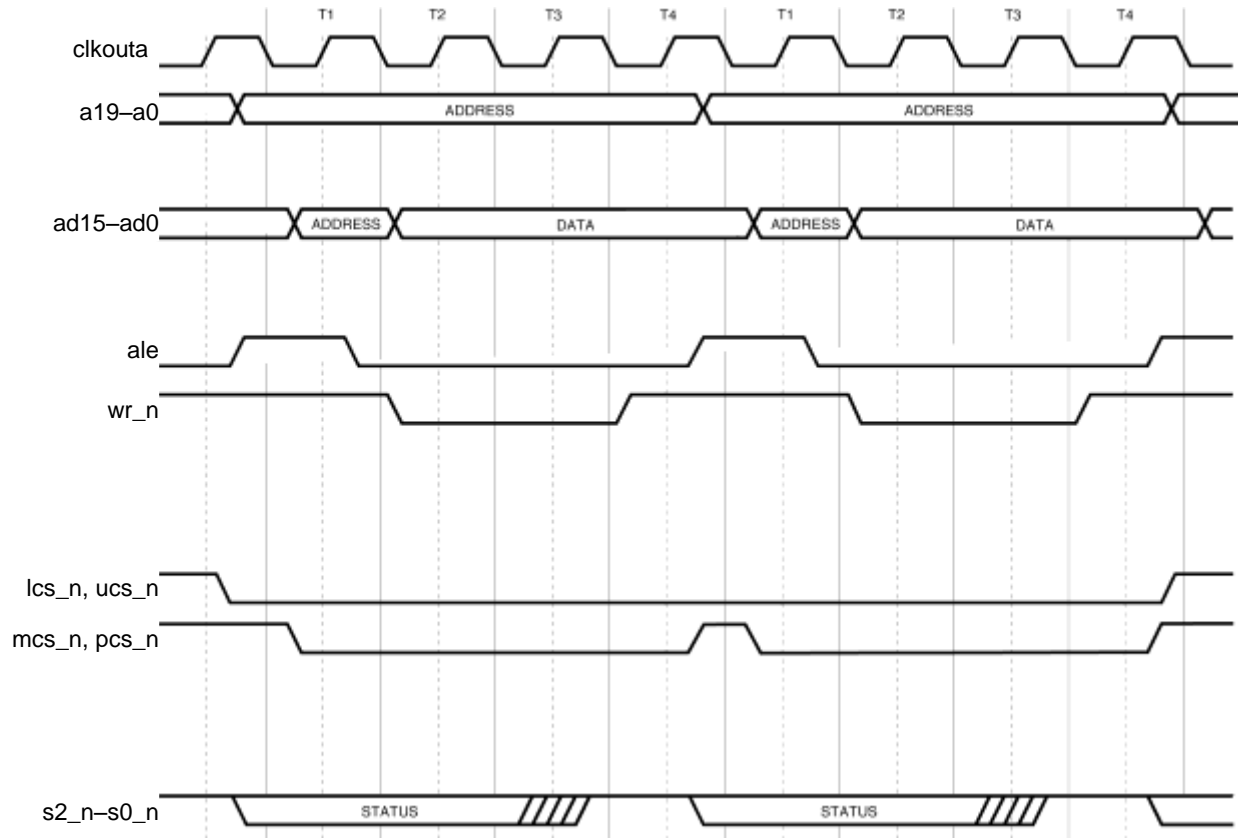

Figure 14. Multiple Write Cycles

Table 84. Write Cycle Timing

No.	Name	Description	Min ^a	Max ^a
General Timing Requirements				
1	tDVCL	Data in Setup	10	–
2	tCLDX	Data in Hold	0	–
General Timing Responses				
3	tCHSV	Status Active Delay	0	6
4	tCLSH	Status Inactive Delay	0	6
5	tCLAV	<i>ad</i> Address Valid Delay	0	12
6	tCLAX	Address Hold	0	12
7	tCLDV	Data Valid Delay	0	12
8	tCHDX	Status Hold Time	0	–
9	tCHLH	<i>ale</i> Active Delay	0	8
10	tLHLL	<i>ale</i> Width	tCLCH-5	–
11	tCHLL	<i>ale</i> Inactive Delay	0	8
12	tAVLL	<i>ad</i> Address Valid to <i>ale</i> Low	tCLCH	–
13	tLLAX	<i>ad</i> Address Hold from <i>ale</i> Inactive	tCHCL	–
14	tAVCH	<i>ad</i> Address Valid to Clock High	0	–
16	tCLCSV	<i>mcs_n/pcs_n</i> Inactive Delay	0	12
17	tCXCSX	<i>mcs_n/pcs_n</i> Hold from Command Inactive	tCLCH	–
18	tCHCSX	<i>mcs_n/pcs_n</i> Inactive Delay	0	12
19	tDXDL	<i>den_n</i> Inactive to <i>dt/r_n</i> Low	0	–
20	tCVCTV	Control Active Delay 1	0	10
22	tCHCTV	Control Active Delay 2	0	9
23	tLHAV	<i>ale</i> High to Address Valid	7.5	–
Write Cycle Timing Responses				
30	tCLDOX	Data Hold Time	0	–
31	tCVCTX	Control Inactive Delay	0	10
32	tWLWH	<i>wr_n</i> Pulse Width	2tCLCL	–
33	tWHLH	<i>wr_n</i> Inactive to <i>ale</i> High	tCLCH	–
34	tWHDX	Data Hold after <i>wr_n</i>	tCLCL	–
35	tWHDEX	<i>wr_n</i> Inactive to <i>den_n</i> Inactive	tCLCH	–
65	tAVWL	<i>a</i> Address Valid to <i>wr_n</i> Low	tCLCL + tCHCL	–
67	tCHCSV	<i>clkouta</i> High to <i>lcs_n/usc_n</i> Valid	0	9
68	tCHAV	<i>clkouta</i> High to <i>a</i> Address Valid	0	8
87	tAVBL	<i>a</i> Address Valid to <i>whb_n/wlb_n</i> Low	tCHCL -1.5	–

^aIn nanoseconds.

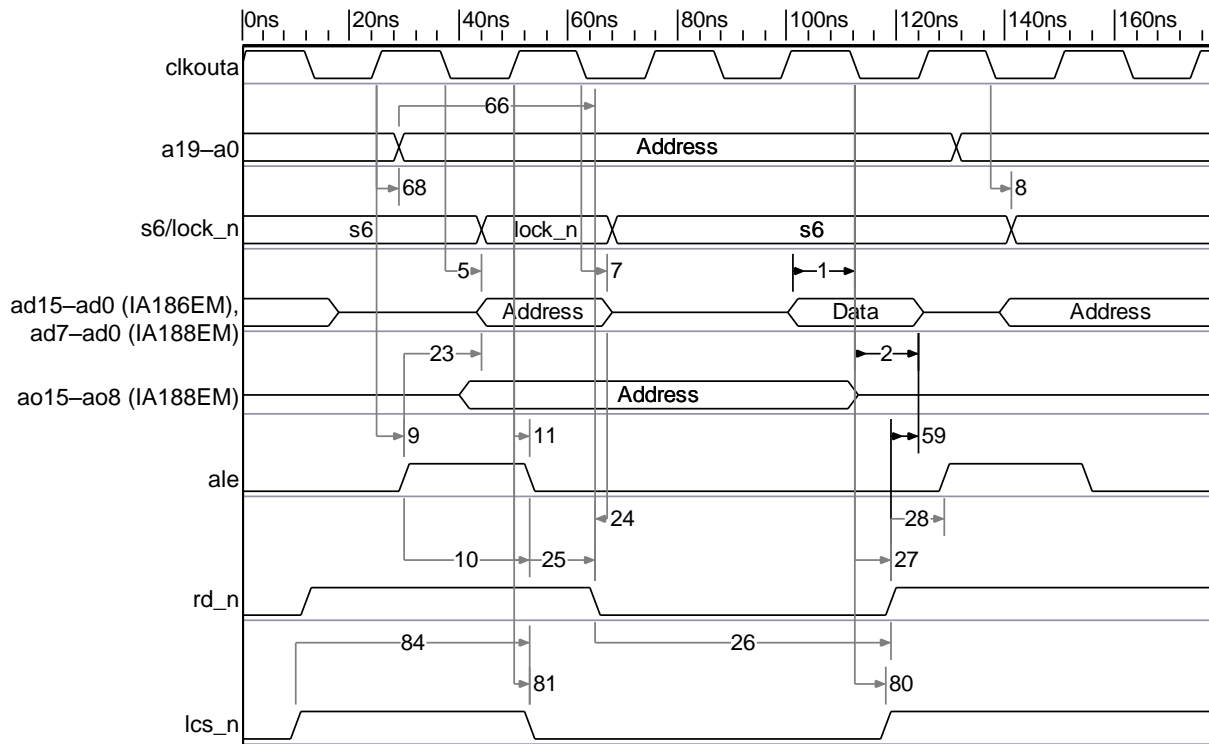

Figure 15. PSRAM Read Cycle

Table 85. PSRAM Read Cycle Timing

No.	Name	Comment	Min ^a	Max ^a
General Timing Requirements				
1	tDVCL	Data in Setup	10	NLL
2	tCLDX	Data in Hold	0	–
General Timing Responses				
5	tCLAV	<i>ad</i> Address Valid Delay	0	12
7	tCLDV	Data Valid Delay	0	12
8	tCHDX	Status Hold Time	0	–
9	tCHLH	<i>ale</i> Active Delay	0	8
10	tLHLL	<i>ale</i> Width	tCHCL-5	–
11	tCHLL	<i>ale</i> Inactive Delay	0	8
23	tLHAV	<i>ale</i> High to Address Valid	7.5	–
80	tCLCLX	<i>lcs_n</i> Inactive Delay	0	9
81	tCLCSL	<i>lcs_n</i> Active Delay	0	9
84	tLRLL	<i>lcs_n</i> Precharge Pulse Width	tCLCL+ tCLCH	–
Read Cycle Timing Responses				
24	tAZRL	<i>ad</i> Address Float to <i>rd_n</i> Active	0	–
25	tCLRL	<i>rd_n</i> Active Delay	0	10
26	tRLRH	<i>rd_n</i> Pulse Width	tCLCL	–
27	tCLRH	<i>rd_n</i> Inactive Delay	0	10
28	tRHLH	<i>rd_n</i> Inactive to <i>ale</i> High	tCLCH	–
59	tRHDX	<i>rd_n</i> High to Data Hold on <i>ad</i> Bus	0	–
66	tAVRL	<i>a</i> Address Valid to <i>rd_n</i> Low	tCLCL+ tCHCL	–
68	tCHAV	<i>clkouta</i> High to <i>a</i> Address Valid	0	8

^aIn nanoseconds.

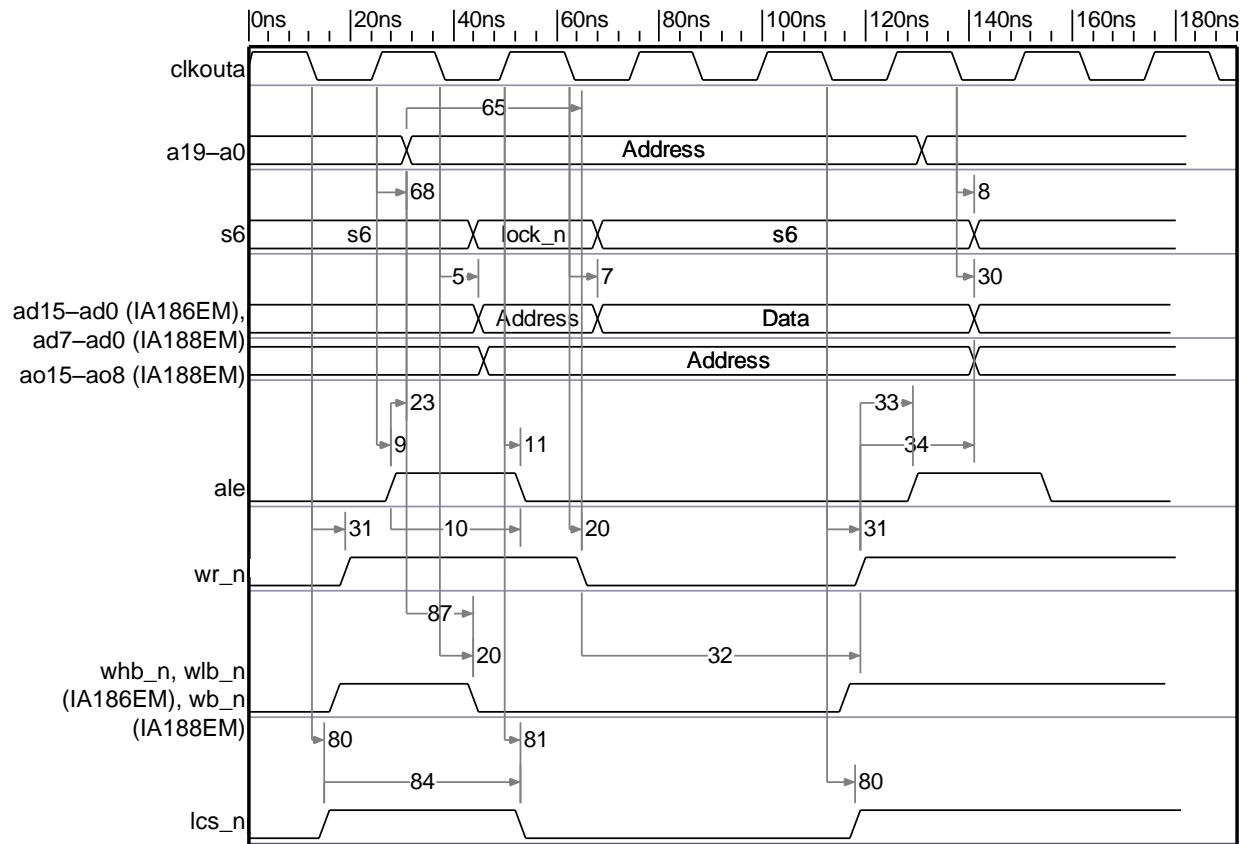

Figure 16. PSRAM Write Cycle

Table 86. PSRAM Write Cycle Timing

No.	Name	Comment	Min ^a	Max ^a
General Timing Requirements				
1	tDVCL	Data in Setup	10	–
2	tCLDX	Data in Hold	0	–
General Timing Responses				
5	tCLAV	<i>ad</i> Address Valid Delay	0	12
7	tCLDV	Data Valid Delay	0	12
8	tCHDX	Status Hold Time	0	–
9	tCHLH	<i>ale</i> Active Delay	0	8
10	tLHLL	<i>ale</i> Width	tCLCH-5	–
11	tCHLL	<i>ale</i> Inactive Delay	NULL	NULL
20	tCVCTV	Control Active Delay 1	0	10
23	tLHAV	<i>ale</i> High to Address Valid	7.5	–
80	tCLCLX	<i>lcs_n</i> Inactive Delay	0	9
81	tCLCSL	<i>lcs_n</i> Active Delay	0	9
84	tLRLL	<i>lcs_n</i> Precharge Pulse Width	tCLCL+ tCLCH	–
Write Cycle Timing Responses				
30	tCLDOX	Data Hold Time	0	–
31	tCVCTX	Control Inactive Delay	0	10
32	tWLWH	<i>wr_n</i> Pulse Width	2tCLCL	–
33	tWHLH	<i>wr_n</i> Inactive to <i>ale</i> High	tCLCH	–
34	tWHDX	Data Hold after <i>wr_n</i>	tCLCL	–
65	tAVWL	<i>a</i> Address Valid to <i>wr_n</i> Low	tCLCL+ tCHCL	–
68	tCHAV	<i>clkouta</i> High to <i>a</i> Address Valid	0	8
87	tAVBL	<i>a</i> Address Valid to <i>whb_n/wlb_n</i> Low	tCHCL -1.5	–

^aIn nanoseconds.

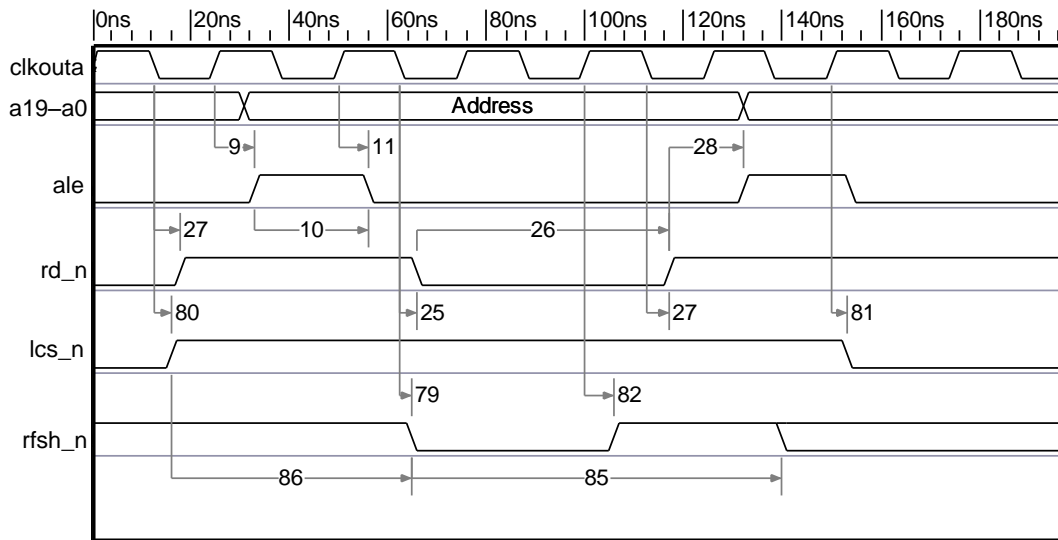

Figure 17. PSRAM Refresh Cycle

Table 87. PSRAM Refresh Cycle

No.	Name	Comment	Min ^a	Max ^a
General Timing Requirements				
1	tDVCL	Data in Setup	10	–
2	tCLDX	Data in Hold	0	–
General Timing Responses				
9	tCHLH	ale Active Delay	0	8
10	tLHLL	ale Width	tCLCH-5	–
11	tCHLL	ale Inactive Delay	0	8
Read/Write Cycle Timing Responses				
25	tCLRL	rd_n Active Delay	0	10
26	tRLRH	rd_n Pulse Width	tCLCL	–
27	tCLRH	rd_n Inactive Delay	0	10
28	tRHLH	rd_n Inactive to ale High	tCLCH	–
80	tCLCLX	lcs_n Inactive Delay	0	9
81	tCLCSL	lcs_n Active Delay	0	9
Refresh Cycle Timing Responses				
79	tCHRFD	clkouta High to rfsh_n Valid	0	12
82	tCLRF	clkouta High to rfsh_n Invalid	0	12
85	tRFCY	rfsh_n Cycle Time	6tCLCL	–
86	tLCRF	lcs_n Inactive to rfsh_n Active Delay	2tCLCL	NULL

^aIn nanoseconds.

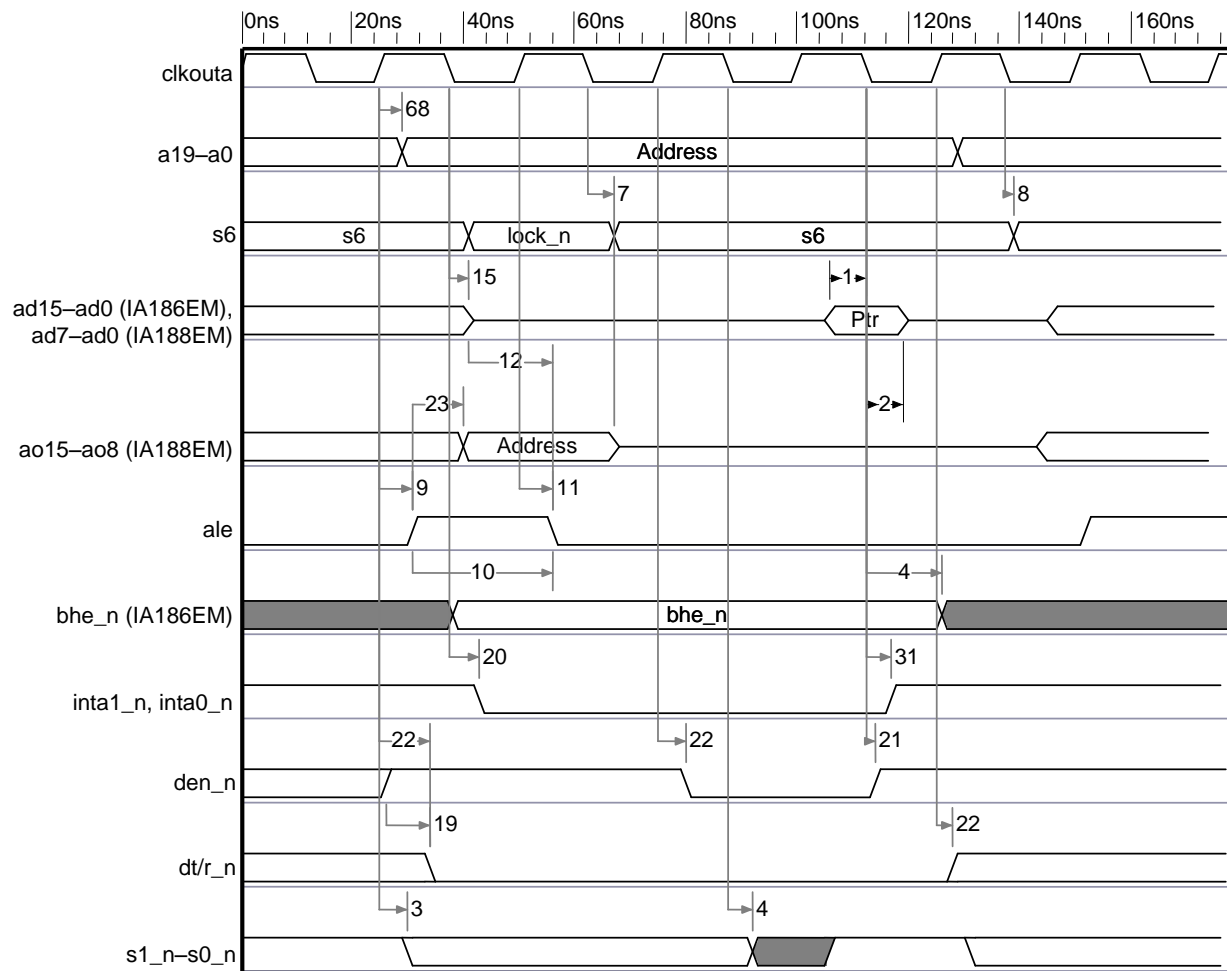

Figure 18. Interrupt Acknowledge Cycle

Table 88. Interrupt Acknowledge Cycle Timing

No.	Name	Description	Min ^a	Max ^a
General Timing Requirements				
1	tDVCL	Data in Setup	10	–
2	tCLDX	Data in Hold	0	–
General Timing Responses				
3	tCHSV	Status Active Delay	0	6
4	tCLSH	Status Inactive Delay	0	6
7	tCLDV	Data Valid Delay	0	12
8	tCHDX	Status Hold Time	0	–
9	tCHLH	ale Active Delay	0	8
10	tLHLL	ale Width	tCLCH-5	–
11	tCHLL	ale Inactive Delay	0	8
12	tAVLL	ad Address Valid to ale Low	tCLCH	–
15	tCLAZ	ad Address Float Delay	0	12
19	tDXDL	den_n Inactive to dt/r_n Low	0	–
20	tCVCTV	Control Active Delay 1	0	10
21	tCVDEX	den_n Inactive Delay	0	9
22	tCHCTV	Control Active Delay 2	0	10
23	tLHAV	ale High to Address Valid	7.5	–
31	tCVCTX	Control Inactive Delay	0	10
68	tCHAV	clkouta High to a Address Valid	0	8

^aIn nanoseconds.

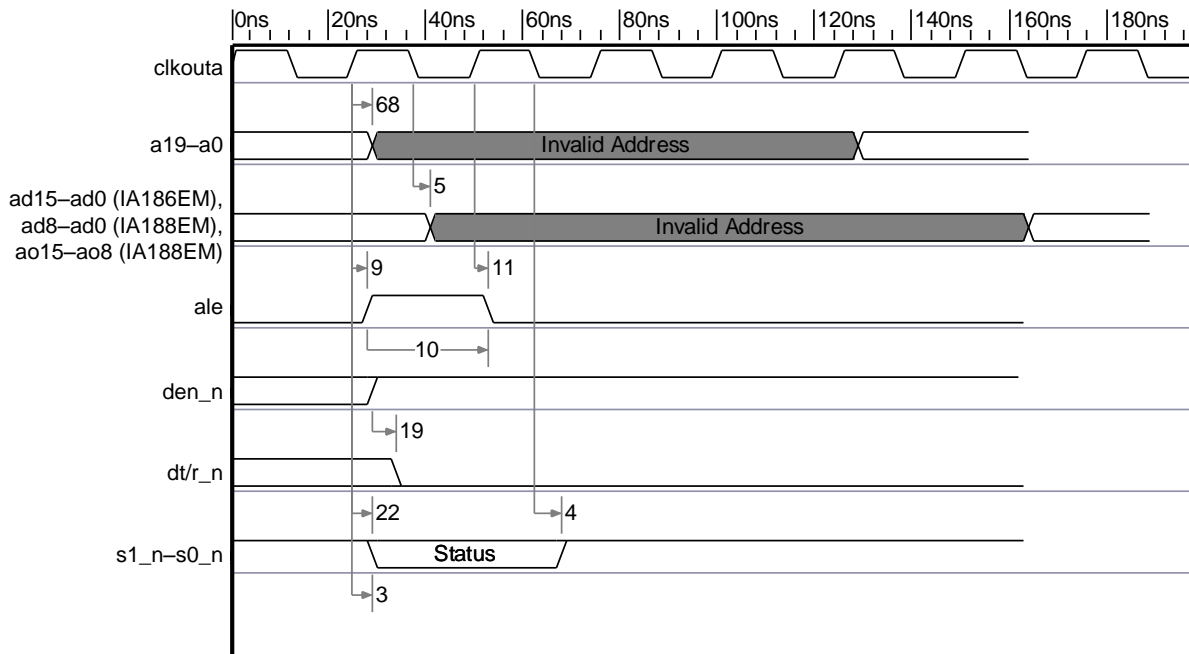

Figure 19. Software Halt Cycle

Table 89. Software Halt Cycle Timing

No.	Name	Description	Min ^a	Max ^a
General Timing Responses				
3	tCHSV	Status Active Delay	0	6
4	tCLSH	Status Inactive Delay	0	6
5	tCLAV	ad Address Valid Delay	0	12
9	tCHLH	ale Active Delay	0	8
10	tLHLL	ale Width	tCLCH-5	–
11	tCHLL	ale Inactive Delay	0	8
19	tDXDL	den_n Inactive to dt/r_n Low	0	–
22	tCHCTV	Control Active Delay 2	0	10
68	tCHAV	clkouta High to a Address Valid	0	8

^aIn nanoseconds.

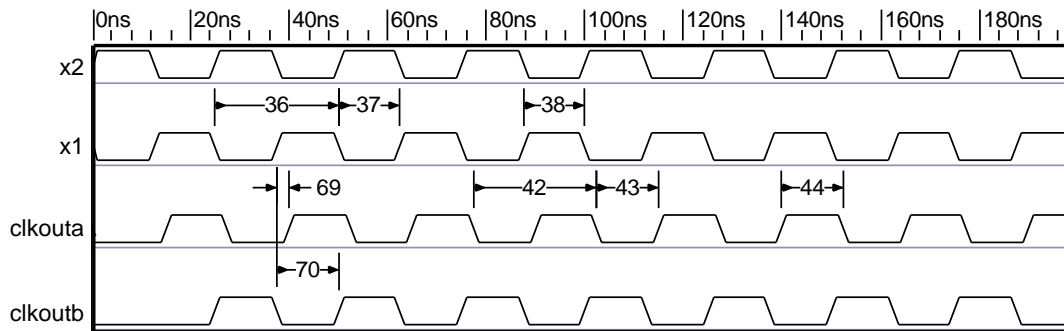

Figure 20. Clock—Active Mode

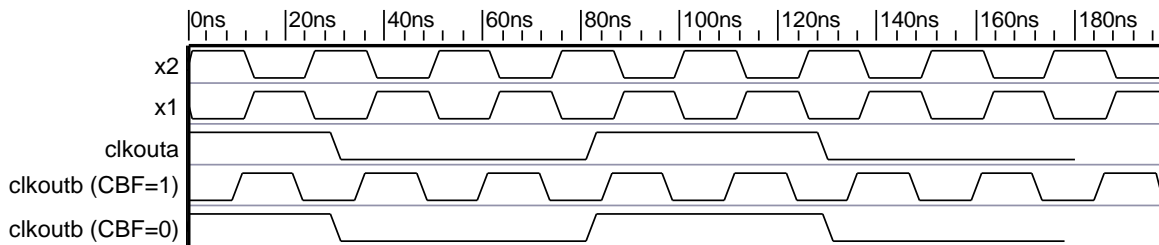

Figure 21. Clock—Power-Save Mode

Table 90. Clock Timing

No.	Name	Description	Min	Max	Units
CLKIN Requirements					
36	tCKIN	x1 Period	25	66	ns
37	tCLCK	x1 Low Time	7.5	–	ns
38	tCHCK	x1 High Time	7.5	–	ns
39	tCKHL	x1 Fall Time	–	5	ns
40	tCKLH	x1 Rise time	–	5	ns
CLKOUT Timing					
42	tCLCL	clkouta Period	25	–	ns
43	tCLCH	clkouta Low Time	tCLCL/2	–	ns
44	tCHCL	clkouta High Time	tCLCL/2	–	ns
45	tCH1CH2	clkouta Rise Time	–	3	ns
46	tCL2CL1	clkouta Fall Time	–	3	ns
61	tLOCK	Maximum PLL Lock Time	–	0.5	ms
69	tCICOA	x1 to clkouta Skew	–	25	ns
70	tCICOB	x1 to clkoutb Skew	–	35	ns

^aIn nanoseconds.

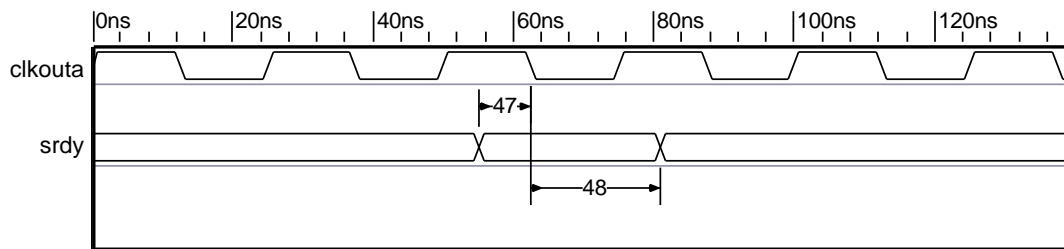

Figure 22. srdy—Synchronous Ready

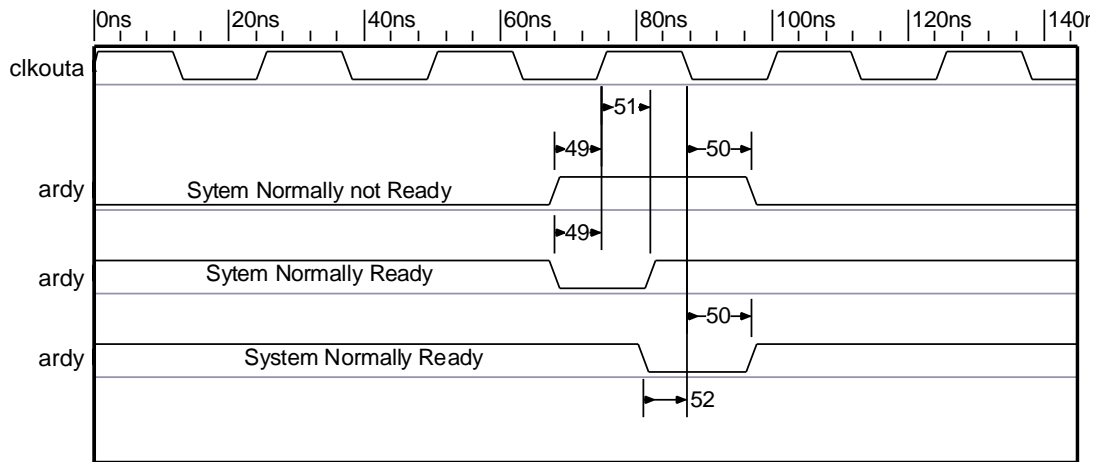

Figure 23. ardy—Asynchronous Ready

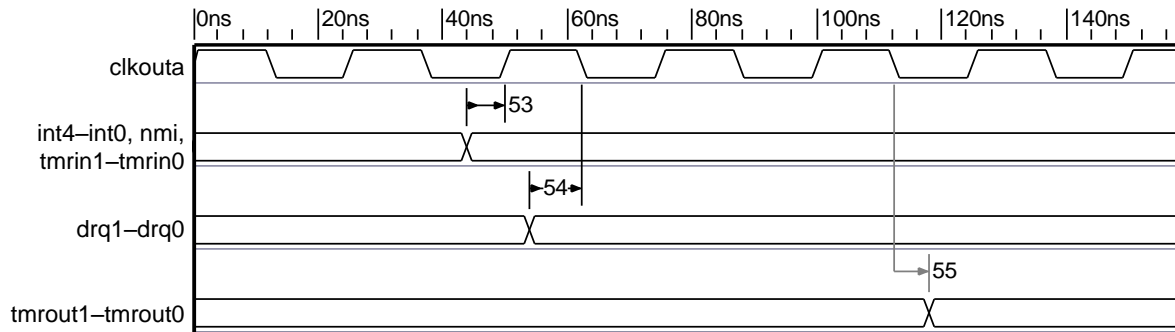

Figure 24. Peripherals

Table 91. Ready and Peripheral Timing

No.	Name	Description	Min ^a	Max ^a
Ready and Peripheral Timing Requirements				
47	tSRYCL	srdy Transition Setup Time	10	–
48	tCLSRY	srdy Transition Hold Time	3	–
49	tARYCH	ardy Resolution Transition Setup Time	9	–
50	tCLARX	ardy Active Hold Time	4	–
51	tARYCHL	ardy Inactive Holding Time	6	–
52	tARYLCL	ardy Setup Time	9	–
53	tINVCH	Peripheral Setup Time	10	–
54	tINVCL	drq Setup Time	10	–
Peripheral Timing Responses				
55	tCLTMV	Timer Output Delay	0	12

^aIn nanoseconds.

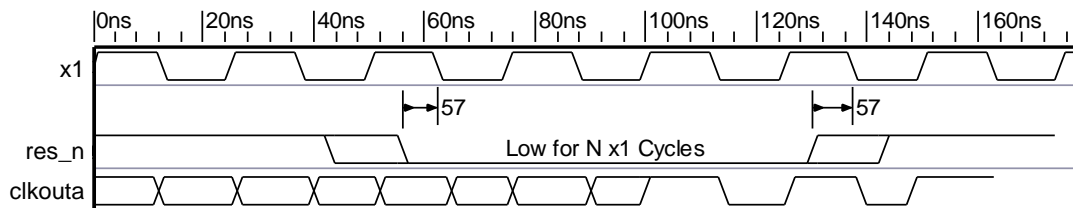

Figure 25. Reset 1

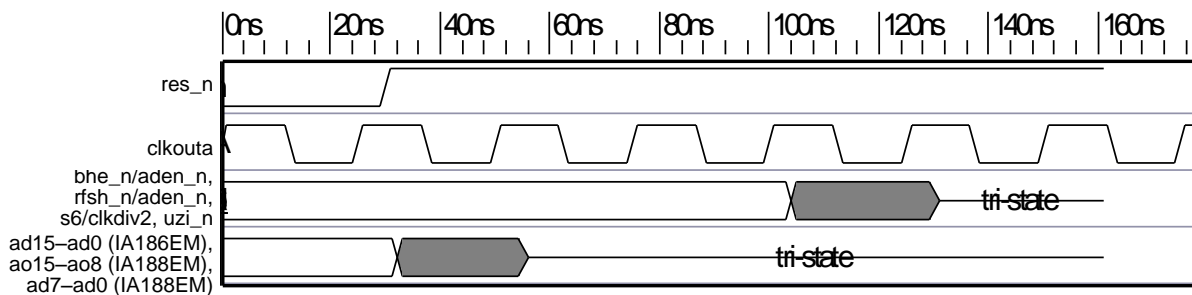

Figure 26. Reset 2

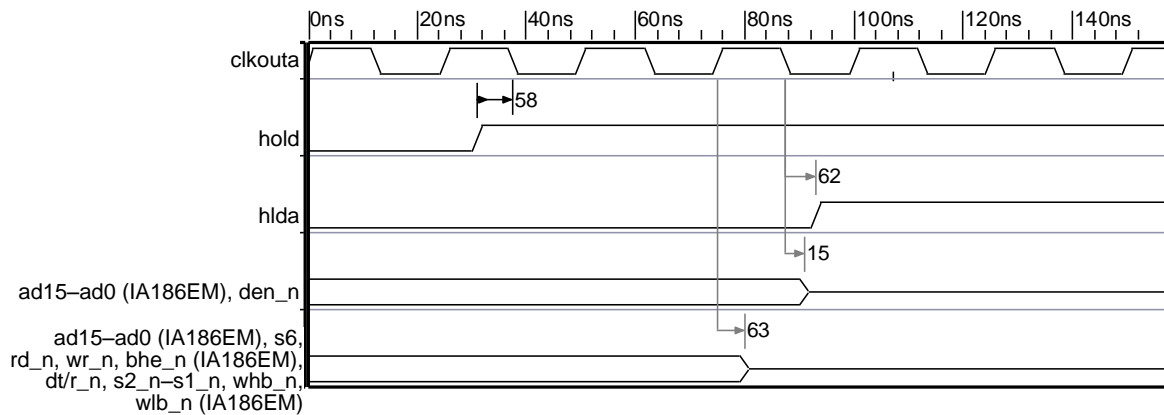

Figure 27. Bus Hold Entering

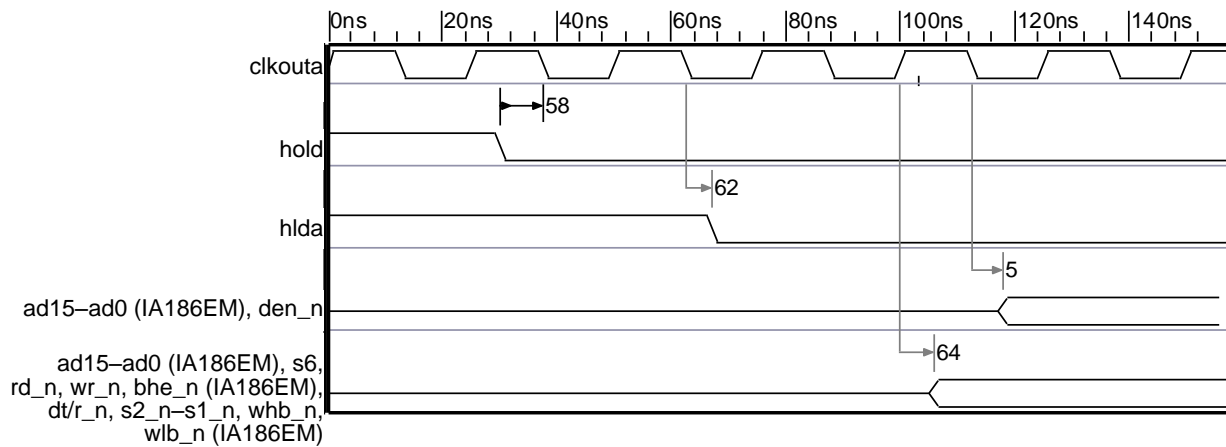

Figure 28. Bus Hold Leaving

Table 92. Reset and Bus Hold Timing

No.	Name	Description	Min ^a	Max ^a
Reset and Bus Hold Timing Requirements				
5	tCLAV	ad Address Valid Delay	0	12
15	tCLAZ	ad Address Float Delay	tCLCH	–
57	tRESIN	res_n Setup Time	10	–
58	tHVCL	hld Setup Time	10	–
Reset and Bus Hold Timing Responses				
62	tCLHAV	hlda Valid Delay	0	7
63	tCHCZ	Command Lines Float Delay	0	12
64	tCHCV	Command Lines Valid Delay (after Float)	0	12

^aIn nanoseconds.

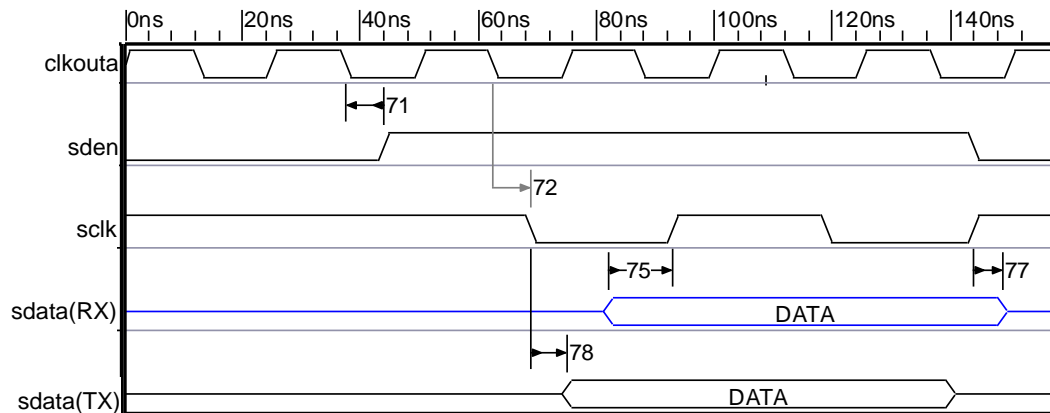

Figure 29. Synchronous Serial Interface

Table 93. Synchronous Serial Interface Timing

No.	Name	Description	Min ^a	Max ^a
Synchronous Serial Port Timing Requirements				
75	tDVSH	Data Valid to sclk high	10	–
77	tSHDX	sclk High to SPI Data Hold	3	–
Synchronous Serial Port Timing Responses				
71	tCLEV	clkouta Low to sden Valid	0	12
72	tCLSL	clkouta Low to sclk Low	0	12
78	tSLDV	sclk Low to Data Valid	0	12

^aIn nanoseconds.

7. Instruction Set Summary Table

Table 94 summarizes each instruction. A key to abbreviations is presented at the end of the table.

Table 94. Instruction Set Summary

Instruction		Opcode - Hex			Clock Cycles		Flags Affected								
Mnemonic	Description	Byte 1	Byte 2	Bytes 3-6	IA186EM	IA188EM	O	D	I	T	S	Z	A	P	C
AAA	ASCII adjust AL after add	37	–	–	8	8	U	–	–	–	U	U	R	U	R
AAD	ASCII adjust AX before divide.	D5	0A	–	15	15	U	–	–	–	R	R	U	R	U
AAM	ASCII adjust AL after multiply	D4	0A	–	19	19	U	–	–	–	R	R	U	R	U
AAS	ASCII adjust AL after subtract	3F	–	–	7	7	U	–	–	–	U	U	R	U	R
ADC	Add imm8 to AL with carry	14	ib	–	3	3	R	–	–	–	R	R	R	R	R
	Add imm16 to AX with carry	15	iw	–	4	4									
	Add imm8 to r/m8 with carry	80	/2 ib	–	4/16	4/16									
	Add imm16 to r/m16 with carry	81	/2 iw	–	4/16	4/20									
	Add sign extended imm8 to r/m16 with carry	83	/2 ib	–	4/16	4/20									
	Add byte reg to r/m8 with carry	10	/r	–	3/10	3/10									
	Add word reg to r/m16 with carry	11	/r	–	3/10	3/14									
	Add r/m8 to byte reg with carry	12	/r	–	3/10	3/10									
	Add r/m16 to word reg with carry	13	/r	–	3/10	3/14									
ADD	Add imm8 to AL	04	ib	–	3	3	R	–	–	–	R	R	R	R	R
	Add imm16 to AX	05	iw	–	4	4									
	Add imm8 to r/m8	80	/0 ib	–	4/16	4/16									
	Add imm16 to r/m16	81	/0 iw	–	4/16	4/20									
	Add sign extended imm8 to r/m16	83	/0 ib	–	4/16	4/20									
	Add byte reg. to r/m8	00	/r	–	3/10	3/10									
	Add word reg. to r/m16	01	/r	–	3/10	3/14									
	Add r/m8 to byte reg	02	/r	–	3/10	3/10									
	Add r/m16 to word reg	03	/r	–	3/10	3/14									

Table 94. Instruction Set Summary (Continued)

Instruction		Opcode - Hex			Clock Cycles		Flags Affected								
Mnemonic	Description	Byte 1	Byte 2	Bytes 3-6	IA186EM	IA188EM	O	D	I	T	S	Z	A	P	C
AND	And imm8 with AL	24	ib		3	3	0	-	-	-	R	R	U	R	0
	And imm16 with AX	25	iw		4	4									
	And imm8 with r/m8	80	/4 ib		4/16	4/16									
	And imm16 with r/m16	81	/4 iw		4/16	4/20									
	And sign-extended imm8 with r/m16	83	/4 ib		4/16	4/20									
	And byte reg. with r/m8	20	/r		3/10	3/10									
	And word reg. with r/m16	21	/r		3/10	3/14									
	And r/m8 with byte reg	22	/r		3/10	3/10									
And r/m16 with word reg	23	/r		3/10	3/14										
BOUND	Check array index against bounds	62	/r	-	33-35	33-35	-	-	-	-	-	-	-	-	-
CALL	Call near, disp relative to next instruction	E8	cw	-	15	19	-	-	-	-	-	-	-	-	-
	Call near, reg indirect mem	FF	/2	-	13/19	17/27									
	Call far to full address given	9A	cd	-	23	31									
	Call far to address at m16:16 word	FF	/3	-	38	54									
CBW	Convert byte integer to word	98	-	-	2	2	-	-	-	-	-	-	-	-	-
CLC	Clear carry flag	F8	-	-	2	2	-	-	-	-	-	-	-	-	-
CLD	Clear direction flag	FC	-	-	2	2	-	0	-	-	-	-	-	-	-
CLI	Clear interrupt-enable flag	FA	-	-	2	2	-	-	0	-	-	-	-	-	-
CMC	Complement carry flag	F5	-	-	2	2	-	-	-	-	-	-	-	-	R
CMP	Compare imm8 to AL	3C	ib		3	3	R	-	-	-	R	R	R	R	R
	Compare imm16 to AX	3D	iw	-	4	4									
	Compare imm8 to r/m8	80	/7 ib		3/10	3/10									
	Compare imm16 to r/m16	81	/7 iw		3/10	3/14									
	Compare sign-extended imm8 to r/m16	83	/7 ib		3/10	3/14									
	Compare byte reg to r/m8	38	/r		3/10	3/10									
	Compare word reg to r/m16	39	/r	-	3/10	3/14									
	Compare r/m8 to byte reg	3A	/r	-	3/10	3/10									
Compare r/m16 to word reg	3B	/r	-	3/10	3/14										
CMPS	Compare byte ES:[DI] to byte segment:[SI]	A6	-	-	22	22	R	-	-	-	R	R	R	R	R
	Compare word ES:[DI] to word segment:[SI]	A7	-	-	22	26									
CMPSB	Compare byte ES:[DI] to byte DS:[SI]	A6	-	-	22	22	R	-	-	-	R	R	R	R	R
CMPSW	Compare word ES:[DI] to word DS:[SI]	A7	-	-	22	26	R	-	-	-	R	R	R	R	R
CS	CS segment reg override prefix	2E	-	-	-	-	-	-	-	-	-	-	-	-	-
CWD	Convert word integer to double word	99	-	-	4	4	-	-	-	-	-	-	-	-	-
DAA	Decimal adjust AL after addition	27	-	-	4	4	U	-	-	-	R	R	R	R	R
DAS	Decimal adjust AL after subtraction	2F	-	-	4	4	U	-	-	-	R	R	R	R	R
DEC	Subtract 1 from r/m8	FE	/1	-	3/15	3/15	R	-	-	-	R	R	R	R	R
	Subtract 1 from r/m16	FF	/1	-	3/15	3/19									
	Subtract 1 from word reg	48+rw			3	3									
DIV	Divide unsigned numbers	F6	mod 110 r/m	-	29/35	29/35	U	-	-	-	U	U	U	U	U

Table 94. Instruction Set Summary (Continued)

Instruction		Opcode - Hex			Clock Cycles		Flags Affected								
Mnemonic	Description	Byte 1	Byte 2	Bytes 3-6	IA186EM	IA188EM	O	D	I	T	S	Z	A	P	C
DS	DS segment override prefix	3E	-	-	-	-	-	-	-	-	-	-	-	-	-
ENTER	Create stack frame for nested procedure	C8	iw ib	-	22+16 (n-1)	26+20 (n-1)	-	-	-	-	-	-	-	-	-
	Create stack frame for non-nested procedure	C8	iw 00	-	15	19	-	-	-	-	-	-	-	-	-
	Create stack frame for nested procedure	C8	iw 01	-	25	29	-	-	-	-	-	-	-	-	-
ES	ES segment reg override prefix	26	-	-	-	-	-	-	-	-	-	-	-	-	-
ESC	Escape - takes a Trap 7	D8	/0	-	-	-	-	-	0	0	-	-	-	-	-
	Escape - takes a Trap 7	D9	/1	-	-	-	-	-	-	-	-	-	-	-	-
	Escape - takes a Trap 7	DA	/2	-	-	-	-	-	-	-	-	-	-	-	-
	Escape - takes a Trap 7	DB	/3	-	-	-	-	-	-	-	-	-	-	-	-
	Escape - takes a Trap 7	DC	/4	-	-	-	-	-	-	-	-	-	-	-	-
	Escape - takes a Trap 7	DD	/5	-	-	-	-	-	-	-	-	-	-	-	-
	Escape - takes a Trap 7	DE	/6	-	-	-	-	-	-	-	-	-	-	-	-
	Escape - takes a Trap 7	DF	/7	-	-	-	-	-	-	-	-	-	-	-	-
HLT	Suspend instruction execution	F4	-	-	2	2	-	-	-	-	-	-	-	-	-
IDIV	Divide Integers AL = AX/(r/m8); AH = remainder	F6	/7	-	44-52 / 50-58	44-52 / 50-58	U	-	-	-	U	U	U	U	U
	Divide Integers AX = DX:AX/(r/m16); DX = remainder	F7	/7	-	53-61 / 59-67	53-61 / 63-71	-	-	-	-	-	-	-	-	-
IMUL	Multiply Integers AX=(r/m8)*AI	F6	/5	-	25-28 / 31-34	25-28 / 31-34	R	-	-	-	U	U	U	U	R
	Multiply Integers DX=(r/m16)*AX	F7	/5	-	34-37 / 40-43	34-37 / 44-47	-	-	-	-	-	-	-	-	-
	Multiply Integers (word reg) = (r/m16)*(sign-ext. byte integer)	6B	/r ib	-	22-25	22-25	-	-	-	-	-	-	-	-	-
	Multiply Integers (word reg) = (word reg)*(sign-ext. byte integer)	6B	/r ib	-	22-25	22-25	-	-	-	-	-	-	-	-	-
	Multiply Integers (word reg) = (r/m16)*(sign-ext. byte integer)	69	/r iw	-	29-32	29-32	-	-	-	-	-	-	-	-	-
	Multiply Integers (word reg) = (word reg)*(sign-ext. byte integer)	69	/r iw	-	29-32	29-32	-	-	-	-	-	-	-	-	-
IN	Input byte from imm port to AL	E4	ib	-	10	10	-	-	-	-	-	-	-	-	-
	Input word from imm port to AX	E5	ib	-	10	14	-	-	-	-	-	-	-	-	-
	Input byte from port in DX to AL	EC	-	-	8	8	-	-	-	-	-	-	-	-	-
	Input word from port in DX to AX	ED	-	-	8	12	-	-	-	-	-	-	-	-	-
INC	Increment r/m8 by 1	FE	/0	-	3/15	3/15	R	-	-	-	R	R	R	R	R
	Increment r/m16 by 1	FF	/0	-	3/15	3/19	-	-	-	-	-	-	-	-	-
	Increment word reg by 1	40+rw	-	-	3	3	-	-	-	-	-	-	-	-	-
INS	Input byte from port in DX to ES:[DI]	6C	-	-	14	14	-	-	-	-	-	-	-	-	-
	Input word from port in DX to ES:[DI]	6D	-	-	-	-	-	-	-	-	-	-	-	-	-
INSB	Input byte from port in DX to ES:[DI]	6C	-	-	-	-	-	-	-	-	-	-	-	-	-

Table 94. Instruction Set Summary (Continued)

Instruction		Opcode - Hex			Clock Cycles		Flags Affected								
Mnemonic	Description	Byte 1	Byte 2	Bytes 3-6	IA186EM	IA188EM	O	D	I	T	S	Z	A	P	C
INSW	Input word from port in DX to ES:[DI]	6D													
INT 3	Generate interrupt 3 (trap to debug)	CC	-	-	45	45	-	-	0	0	-	-	-	-	-
INT	Generate type of interrupt specified by imm8	CD	ib	-	47	47									
INTO	Generate interrupt 4 if Overflow Flag (O) is 1	CE	-	-	48, 4	48, 4									
IRET	Interrupt return	CF	-	-	28	28	Restores value of flags reg that was stored on the stack when the interrupt was taken.								
JA	Jump short if above (C & Z = 0)	77	cb	-	13, 4	13, 4	-	-	-	-	-	-	-	-	-
JNBE	Jump short if not below or equal														
JAE	Jump short if above or equal (C=0)	73	cb	-	13, 4	13, 4	-	-	-	-	-	-	-	-	-
JNB	Jump short if not below (C=0)														
JNC	Jump short if not carry (C=0)														
JB	Jump short if below (C=1)	72	cb	-	13, 4	13, 4	-	-	-	-	-	-	-	-	-
JC	Jump short if carry (C=1)														
JNAE	Jump short if not above or equal (C=1)														
JBE	Jump short if below or equal (C & Z = 0)	76	cb	-	13, 4	13, 4	-	-	-	-	-	-	-	-	-
JNA	Jump short if not above (C & Z = 0)														
JCXZ	Jump short if CX reg is 0	E3	cb	-	15,5	15,5	-	-	-	-	-	-	-	-	-
JE	Jump short if equal (Z=1)	74	cb	-	13, 4	13, 4	-	-	-	-	-	-	-	-	-
JZ	Jump short if 0 (Z=1)														
JG	Jump short if greater (Z & S = 0)	7F	cb	-	13, 4	13, 4	-	-	-	-	-	-	-	-	-
JNLE	Jump short if not less or equal (Z & S = 0)														
JGE	Jump short if greater or equal (S=0)	7D	cb	-	13, 4	13, 4	-	-	-	-	-	-	-	-	-
JNL	Jump short if not less (S = 0)														
JLE	Jump short if less or equal (Z & S = 0)	7E	cb	-	13, 4	13, 4	-	-	-	-	-	-	-	-	-
JNG	Jump short if not greater (Z & S = 0)														
JMP	Jump short direct, disp relative to next instruction	EB	cb	-	14	14	-	-	-	-	-	-	-	-	-
	Jump near direct, disp relative to next instruction	E9	cw	-	14	14									
	Jump near indirect	FF	/4	-	11/17	11/21									
	Jump far direct to doubleword imm address	EA	cd	-	14	14									
	Jump m16: 16 indirect and far	FF	/5	-	26	34									
JNE	Jump short if not equal (Z=0)	75	cb	-	13, 4	13, 4	-	-	-	-	-	-	-	-	-
JNZ	Jump short if not zero (Z=0)														
JNO	Jump short if not overflow (O=1)	71	cb	-	13, 4	13, 4	-	-	-	-	-	-	-	-	-
JNP	Jump short if not parity (P=0)	7B	cb	-	13, 4	13, 4	-	-	-	-	-	-	-	-	-
JPO	Jump short if parity odd (P=0)														
JNS	Jump short if not sign (S=0)	79	cb	-	13, 4	13, 4	-	-	-	-	-	-	-	-	-
JO	Jump short if overflow (O=1)	70	cb	-	13, 4	13, 4	-	-	-	-	-	-	-	-	-
JP	Jump short if parity (P=1)	7A	cb	-	13, 4	13, 4	-	-	-	-	-	-	-	-	-
JPE	Jump short if parity (P=1)														

Table 94. Instruction Set Summary (Continued)

Instruction		Opcode - Hex			Clock Cycles		Flags Affected								
Mnemonic	Description	Byte 1	Byte 2	Bytes 3-6	IA186EM	IA188EM	O	D	I	T	S	Z	A	P	C
JS	Jump short if sign (S=1)	78	cb	–	13, 4	13, 4	–	–	–	–	–	–	–	–	–
LAHF	Load AH with low byte of flags reg	9F	–	–	2	2	–	–	–	–	–	–	–	–	–
LDS	Load DS:r16 with segment offset from memory	C5	/r	–	18	26	–	–	–	–	–	–	–	–	–
LEA	Load offset for m16 word in 16-bit reg	8D	/r	–	6	6	–	–	–	–	–	–	–	–	–
LEAVE	Destroy procedure stack frame	C9	–	–	8	8	–	–	–	–	–	–	–	–	–
LES	Load ES:r16 with segment offset from memory	C4	/r	–	18	26	–	–	–	–	–	–	–	–	–
LOCK	Asserts lock_n during an instruction execution	F0	–	–	1	1	–	–	–	–	–	–	–	–	–
LODS	Load byte segment :[SI] in AL	AC	–	–	12	12	–	–	–	–	–	–	–	–	–
	Load word segment :[SI] in AX	AD			12	16									
LODSB	Load byte DS:[SI] in AL	AC			12	12									
LODSW	Load word DS:[SI] in AX	AD			12	16									
LOOP	Decrement count; jump short if CX ≠ 0	E2	–	–	16, 6	16, 6	–	–	–	–	–	–	–	–	–
LOOPE	Decrement count; jump short if CX ≠ 0 and Z = 1	E1	cb	–											
LOOPZ	Decrement count; jump short if CX ≠ 0 and Z = 1														
LOOPNE	Decrement count; jump short if CX ≠ 0 and Z = 0	E0	cb	–	16, 6	16, 6	–	–	–	–	–	–	–	–	–
LOOPNZ	Decrement count; jump short if CX ≠ 0 and Z = 0														
MOV	Copy reg to r/m8	88	/r	–	2/12	2/12	–	–	–	–	–	–	–	–	–
	Copy reg to r/m16	89	/r	–	2/12	2/16									
	Copy r/m8 to reg	8A	/r	–	2/9	2/9									
	Copy r/m16 to reg	8B	/r	–	2/9	2/13									
	Copy segment reg to r/m16	8C	/sr	–	2/11	2/15									
	Copy r/m16 to segment reg	8E	/sr	–	2/9	2/13									
	Copy byte at segment offset to AL	A0	–	–	8	8									
	Copy word at segment offset to AX	A1	–	–	8	12									
	Copy AL to byte at segment offset	A2	–	–	9	9									
	Copy AX to word at segment offset	A3	–	–	9	13									
	Copy imm8 to reg	B0+rb	–	–	3	3									
	Copy imm16 to reg	B8+rw			3	4									
	Copy imm8 to r/m8	C6	/0	–	12	12									
Copy imm16 to r/m16	C7	/0	–	12	13										
MOVS	Copy byte segment [SI] to ES:[DI]	A4	–	–	14	14	–	–	–	–	–	–	–	–	–
	Copy word segment [SI] to ES:[DI]	A5	–	–	14	18									
MOVSB	Copy byte DS:[SI] to ES:[DI]	A4	–	–	14	14									
MOVSW	Copy word DS:[SI] to ES:[DI]	A5	–	–	14	18									

Table 94. Instruction Set Summary (Continued)

Instruction		Opcode - Hex			Clock Cycles		Flags Affected								
Mnemonic	Description	Byte 1	Byte 2	Bytes 3-6	IA186EM	IA188EM	O	D	I	T	S	Z	A	P	C
MUL	AX = (r/m8) * AL	F6	/4	–	26–28 / 32–34	26–28 / 32–34	R	–	–	–	–	–	–	–	R
	DX::AX = (r/m16) * AX	F7	/4	–	35–37 / 41–43	35–37 / 45–47									
NEG	Perform 2's complement negation of r/m8	F6	/3	–	3/10	3/10	R	–	–	–	R	R	R	R	R
	Perform 2's complement negation of r/m16	F7	/3	–	3/10	3/14									
NOP	Perform no operation	90	–	–	3	3	–	–	–	–	–	–	–	–	–
NOT	Complement each bit in r/m8	F6	/2	–	3/10	3/10	–	–	–	–	–	–	–	–	–
	Complement each bit in r/m16	F7	/2	–	3/10	3/14									
OR	OR imm8 with AL	0C	ib	–	3	3	0	–	–	–	R	R	U	R	0
	OR imm16 with AX	0D	iw	–	4	4									
	OR imm8 with r/m8	80	/1 ib	–	4/16	4/16									
	OR imm16 with r/m16	81	/1 iw	–	4/16	4/20									
	OR imm8 with r/m16	83	/1 ib	–	4/16	4/20									
	OR byte reg with r/m8	08	/r	–	3/10	3/10									
	OR word reg with r/m16	09	/r	–	3/10	3/14									
	OR r/m8 with byte reg	0A	/r	–	3/10	3/10									
	OR r/m16 with word reg	0B	/r	–	3/10	3/14									
OUT	Output AL to imm port	E6	ib	–	9	9	–	–	–	–	–	–	–	–	–
	Output AX to imm port	E7	ib	–	9	13									
	Output AL to port in DX	EE	–	–	7	7									
	Output AX to port in DX	EF	–	–	7	11									
OUTS	Output byte DS:[SI] to port in DX	6E	–	–	14	14	–	–	–	–	–	–	–	–	–
	Output word DS:[SI] to port in DX	6F	–	–											
OUTSB	Output byte DS:[SI] to port in DX	6E	–	–											
OUTSW	Output word DS:[SI] to port in DX	6F	–	–											
POP	Pop top word of stack into memory word	8F	/0	–	20	24	–	–	–	–	–	–	–	–	–
	Pop top word of stack into word reg	58+rw	–	–	10	14									
	Pop top word of stack into DS	1F	–	–	8	12									
	Pop top word of stack into ES	07	–	–											
	Pop top word of stack into SS	17	–	–											
POPA	Pop DI, SI, BP, BX, DX, CX, & AX	61	–	–	51	83	Values in word at top of stack are copied into FLAGS reg bits.								
POPF	Pop top word of stack into Processor Status Flags reg	9D	–	–	8	12									
PUSH	Push memory word onto stack	FF	/6	–	16	20	–	–	–	–	–	–	–	–	–
	Push reg word onto stack	50+rw	–	–	10	14									
	Push sign-extended imm8 onto stack	6A	–	–	10	14									
	Push imm16 onto stack	68	–	–	10	14									
	Push CS onto stack	0E	–	–	9	13									
	Push SS onto stack	16	–	–	9	13									
	Push DS onto stack	1E	–	–	9	13									
	Push ES onto stack	06	–	–	9	13									
PUSHA	Push AX, CX, DX, BX, original SP, BP, SI, and DI	60	–	–	36	68	–	–	–	–	–	–	–	–	–

Table 94. Instruction Set Summary (Continued)

Mnemonic	Instruction Description	Opcode - Hex			Clock Cycles		Flags Affected								
		Byte 1	Byte 2	Bytes 3-6	IA186EM	IA188EM	O	D	I	T	S	Z	A	P	C
PUSHF	Push Processor Status Flags reg	9C	-	-	9	13	-	-	-	-	-	-	-	-	-
RCL	Rotate 9 bits of C and r/m8 left once	D0	/2	-	2/15	2/15	-	-	-	-	-	-	-	-	-
	Rotate 9 bits of C and r/m8 left CL times	D2	/2	-	5+n/ 17+n	5+n/ 17+n	-	-	-	-	-	-	-	-	-
	Rotate 9 bits of C and r/m8 left imm8 times	C0	/2 ib	-	5+n/ 17+n	5+n/ 17+n	-	-	-	-	-	-	-	-	-
	Rotate 17 bits of C and r/m16 left once	D1	/2	-	2/15	2/15	-	-	-	-	-	-	-	-	-
	Rotate 17 bits of C and r/m16 left CL times	D3	/2	-	5+n/ 17+n	5+n/ 17+n	-	-	-	-	-	-	-	-	-
	Rotate 17 bits of C and r/m16 left imm8 times	C1	/2 ib	-	5+n/ 17+n	5+n/ 17+n	-	-	-	-	-	-	-	-	-
RCR	Rotate 9 bits of C and r/m8 right once	D0	/3	-	2/15	2/15	-	-	-	-	-	-	-	-	-
	Rotate 9 bits of C and r/m8 right CL times	D2	/3	-	5+n/ 17+n	5+n/ 17+n	-	-	-	-	-	-	-	-	-
	Rotate 9 bits of C and r/m8 right imm8 times	C0	/3 ib	-	5+n/ 17+n	5+n/ 17+n	-	-	-	-	-	-	-	-	-
	Rotate 17 bits of C and r/m16 right once	D1	/3	-	2/15	2/15	-	-	-	-	-	-	-	-	-
	Rotate 17 bits of C and r/m16 right CL times	D3	/3	-	5+n/ 17+n	5+n/ 17+n	-	-	-	-	-	-	-	-	-
	Rotate 17 bits of C and r/m16 right imm8 times	75	/3 ib	-	5+n/ 17+n	5+n/ 17+n	-	-	-	-	-	-	-	-	-
REP INS	Input CX bytes from port in DX to ES:[DI]	F3	6C	-	8+8n	8+8n	-	-	-	-	-	-	-	-	-
	Input CX bytes from port in DX to ES:[DI]	F3	6D	-	8+8n	12+8n	-	-	-	-	-	-	-	-	-
REP LODS	Load CX bytes from segment :[SI] in AL	F3	AC	-	6+11n	6+11n	-	-	-	-	-	-	-	-	-
	Load CX words from segment :[SI] in AX	F3	AD	-	6+11n	10+ 11n	-	-	-	-	-	-	-	-	-
REP MOVS	Copy CX bytes from segments :[SI] to ES:[DI]	F3	A4	-	8+8n	8+8n	-	-	-	-	-	-	-	-	-
	Copy CX words from segments :[SI] to ES:[DI]	F3	A5	-	8+8n	12+8n	-	-	-	-	-	-	-	-	-
REP OUTS	Output CX bytes from DS:[SI] to port in DX	F3	6E	-	8+8n	8+8n	-	-	-	-	-	-	-	-	-
	Output CX bytes from DS:[SI] to port in DX	F3	6F	-	8+8n	12+8n	-	-	-	-	-	-	-	-	-
REP STOS	Fill CX bytes at ES:[DI] with AL	F3	AA	-	8+8n	8+8n	-	-	-	-	-	-	-	-	-
	Fill CX words at ES:[DI] with AL	F3	AB	-	8+8n	12+8n	-	-	-	-	-	-	-	-	-
REPE CMPS	Find non-matching bytes in ES:[DI] and segment :[SI]	F3	A6	-	5+22n	5+22n	-	-	-	-	-	-	-	-	-
	Find non-matching words in ES:[DI] and segment :[SI]	F3	A7	-	5+22n	9+22n	-	-	-	-	-	-	-	-	-
REPE SCAS	Find non-AL byte starting at ES:[DI]	F3	AE	-	5+15n	5+15n	-	-	-	-	-	-	-	-	-
	Find non-AX word starting at ES:[DI]	F3	AF	-	5+15n	9+15n	-	-	-	-	-	-	-	-	-
REPZ CMPS	Find non-matching bytes in ES:DI and segment :[SI]	F3	A6	-	5+22n	5+22n	-	-	-	-	-	-	-	-	-
	Find non-matching words in ES:DI and segment :[SI]	F3	A7	-	5+22n	9+22n	-	-	-	-	-	-	-	-	-

Table 94. Instruction Set Summary (Continued)

Instruction		Opcode - Hex			Clock Cycles		Flags Affected								
Mnemonic	Description	Byte 1	Byte 2	Bytes 3-6	IA186EM	IA188EM	O	D	I	T	S	Z	A	P	C
REPZ SCAS	Find non-AL byte starting at ES:DI	F3	AE	–	5+15n	5+15n									
	Find non-AX word starting at ES:DI	F3	AF	–	5+15n	9+15n									
REPNE CMPS	Find matching bytes in ES:[DI] and segment ;[SI]	F2	A6	–	5+22n	5+22n	–	–	–	–	–	–	–	–	–
	Find matching words in ES:[DI] and segment ;[SI]	F2	A7	–	5+22n	9+22n									
REPZ CMPS	Find AL byte starting at ES:[DI]	F2	A6	–	5+22n	5+22n									
	Find AX word starting at ES:[DI]	F2	A7	–	5+22n	9+22n									
REPNE SCAS	Find matching bytes in ES:DI and segment ;[SI]	F2	AE	–	5+15n	5+15n									
	Find matching words in ES:DI and segment ;[SI]	F2	AF	–	5+15n	9+15n									
REPZ SCAS	Find AL byte starting at ES:DI	F2	AE	–	5+15n	5+15n									
	Find AX word starting at ES:DI	F2	AF	–	5+15n	9+15n									
RET	Return near to calling procedure	C3			16	20	–	–	–	–	–	–	–	–	–
	Return far to calling procedure	CB	data low	data high	22	30									
	Return near; pop imm16 parameters	C2			18	22									
	Return far; pop imm16 parameters	CA	data low	data high	25	33									
ROL	Rotate 8 bits of r/m8 left once	D0	/0	–	2/15	2/15	U	–	–	–	–	–	–	–	R
	Rotate 8 bits or r/m8 left CL times	D2	/0	–	5+n/ 17+n	5+n/ 17+n									
	Rotate 8 bits or r/m8 left imm8 times	C0	/0 ib	data 8	5+n/ 17+n	5+n/ 17+n									
	Rotate 16 bits of r/m8 left once	D1	/0	–	2/15	2/15									
ROL	Rotate 16 bits or r/m8 left CL times	D3	/0	–	5+n/ 17+n	5+n/ 17+n	U	–	–	–	–	–	–	–	R
	Rotate 16 bits or r/m8 left imm8 times	C1	/0 ib	data 8	5+n/ 17+n	5+n/ 17+n									
ROR	Rotate 8 bits of r/m8 right once	D0	/1	–	2/15	2/15	U	–	–	–	–	–	–	–	R
	Rotate 8 bits or r/m8 right CL times	D2	/1	–	5+n/ 17+n	5+n/ 17+n									
	Rotate 8 bits or r/m8 right imm8 times	C0	/1 ib	data 8	5+n/ 17+n	5+n/ 17+n									
	Rotate 16 bits of r/m8 right once	D1	/1	–	2/15	2/15									
	Rotate 16 bits or r/m8 right CL times	D3	/1	–	5+n/ 17+n	5+n/ 17+n									
	Rotate 16 bits or r/m8 right imm8 times	C1	/1 ib	data 8	5+n/ 17+n	5+n/ 17+n									
SAHF	Show AH in low byte of the Status Flags reg	9E	–	–	3	3	–	–	–	–	R	R	R	R	R

Table 94. Instruction Set Summary (Continued)

Mnemonic	Instruction Description	Opcode - Hex			Clock Cycles		Flags Affected								
		Byte 1	Byte 2	Bytes 3-6	IA186EM	IA188EM	O	D	I	T	S	Z	A	P	C
SAL/SHL	Multiply r/m8 by 2, once	D0	/4	–	2/15	2/15	U	–	–	–	–	R	R	R	R
	Multiply r/m8 by 2, CL times	D2	/4	–	5+n/ 17+n	5+n/ 17+n									
	Multiply r/m8 by 2, imm8 times	C0	/4 ib	data 8	5+n/ 17+n	5+n/ 17+n									
	Multiply r/m16 by 2, once	D1	/4	–	2/15	2/15									
	Multiply r/m16 by 2, CL times	D3	/4	–	5+n/ 17+n	5+n/ 17+n									
	Multiply r/m16 by 2, imm8 times	C1	/4 ib	data 8	5+n/ 17+n	5+n/ 17+n									
	Multiply r/m8 by 2, once	D0	/4	–	2/15	2/15									
	Multiply r/m8 by 2, CL times	D2	/4	–	5+n/ 17+n	5+n/ 17+n									
	Multiply r/m8 by 2, imm8 times	C0	/4 ib	data 8	5+n/ 17+n	5+n/ 17+n									
	Multiply r/m16 by 2, once	D1	/4	–	2/15	2/15									
	Multiply r/m16 by 2, CL times	D3	/4	–	5+n/ 17+n	5+n/ 17+n									
	Multiply r/m16 by 2, imm8 times	C1	/4 ib	data8	5+n/ 17+n	5+n/ 17+n									
SAR	Perform a signed division of r/m8 by 2, once	D0	/7	–	2/15	2/15	U	–	–	–	R	R	U	R	R
	Perform a signed division of r/m8 by 2, CL times	D2	/7	–	5+n/ 17+n	5+n/ 17+n									
	Perform a signed division of r/m8 by 2, imm8 times	C0	/7 ib	data 8	5+n/ 17+n	5+n/ 17+n									
	Perform a signed division of r/m16 by 2, once	D1	/7	–	2/15	2/15									
	Perform a signed division of r/m16 by 2, CL times	D3	/7	–	5+n/ 17+n	5+n/ 17+n									
	Perform a signed division of r/m16 by 2, imm8 times	C1	/7 ib	data 8	5+n/ 17+n	5+n/ 17+n									
SBB	Subtract imm8 from AI with borrow	1C	ib	–	3	3	R	–	–	–	R	R	R	R	R
	Subtract imm16 from AX with borrow	1D	iw	data 8	4	4									
	Subtract imm8 from r/m8 with borrow	80	/3 ib	–	4/16	4/16									
	Subtract imm16 from r/m16 with borrow	81	/3 iw	–	4/16	4/20									
	Subtract sign-extended imm8 from r/m16 with borrow	83	/3 ib	–	4/16	4/20									
	Subtract byte reg from r/m8 with borrow	18	/r	data8	3/10	3/10									
	Subtract word reg from r/m16 with borrow	19	/r	–	3/10	3/14									
	Subtract r/m8 from r/m8 with borrow	1A	/r	–	3/10	3/10									
	Subtract r/m8 reg from byte with borrow	1B	/r	data 8	3/10	3/14									
SCAS	Compare byte AL to ES:[DI]; update DI	AE	–	–	15	19	R	–	–	–	R	R	R	R	R
	Compare word AL to ES:[DI]; update DI	AF	–	–	15	19									

Table 94. Instruction Set Summary (Continued)

Instruction		Opcode - Hex			Clock Cycles		Flags Affected								
Mnemonic	Description	Byte 1	Byte 2	Bytes 3-6	IA186EM	IA188EM	O	D	I	T	S	Z	A	P	C
SCASB	Compare byte AL to ES:[DI]; update DI	AE	-	-	15	19									
SCASW	Compare word AL to ES:[DI]; update DI	AF	-	-	15	19									
SHR	Divide unsigned of r/m8 by 2, once	D0	/7	-	2/15	2/15	U	-	-	-	R	R	U	R	0
	Divide unsigned of r/m8 by 2, CL times	D2	/7	-	5+n/ 17+n	5+n/ 17+n									
	Divide unsigned of r/m8 by 2, imm8 times	C0	/7 ib	data 8	5+n/ 17+n	5+n/ 17+n									
	Divide unsigned of r/m16 by 2, once	D1	/7	-	2/15	2/15									
	Divide unsigned of r/m16 by 2, CL times	D3	/7	-	5+n/ 17+n	5+n/ 17+n									
	Divide unsigned of r/m16 by 2, imm8 times	C1	/7 ib	data 8	5+n/ 17+n	5+n/ 17+n									
SS	SS segment reg override prefix	36	-	-	-	-	-	-	-	-	-	-	-	-	-
STC	Set the Carry Flag to 1	F9	-	-	2	2	-	-	-	-	-	-	-	-	1
STD	Set the Direction Flag so the source Index (SI) and/or the Destination Index (DI) regs will decrement during string instructions	FD	-	-	2	2	-	1	-	-	-	-	-	-	-
STI	Enable maskable interrupts after the next instruction	FB	-	-	2	2	-	-	1	-	-	-	-	-	-
STOS	Store AL in byte ES:[DI]; update DI	AA	-	-	10	10	-	-	-	-	-	-	-	-	-
	Store AX in word ES:[DI]; update DI	AB	-	-	10	14									
STOSB	Store AL in byte ES:[DI]; update DI	AA	-	-	10	10									
STOSW	Store AX in word ES:[DI]; update DI	AB	-	-	10	14									
SUB	Subtract imm8 from AL	2C	ib	-	3	3	R	-	-	-	R	R	R	R	R
	Subtract imm16 from AX	2D	iw	-	4	4									
	Subtract imm8 from r/m8	80	/5 ib	-	4/16	4/16									
	Subtract imm16 from r/m16	81	/5 iw	-	4/16	4/20									
	Subtract sign-extended imm8 from r/m16	83	/5 ib	-	4/16	4/20									
	Subtract byte reg from r/m8	28	/r	-	3/10	3/10									
	Subtract word reg from r/m16	29	/r	-	3/10	3/14									
	Subtract r/m8 from byte reg	2A	/r	-	3/10	3/10									
	Subtract r/m16 from word reg	2B	/r	-	3/10	3/14									
TEST	AND imm8 with AL	A8	ib	-	3	3	0	-	-	-	R	R	U	R	0
	AND imm16 with AX	A9	iw	-	4	4									
	AND imm8 with r/m8	F6	/0 ib	data 8	4/10	4/10									
	AND imm16 with r/m16	F7	/0 iw	-	4/10	4/14									
	AND byte reg with r/m8	84	/r	-	3/10	3/10									
	AND word reg with r/m16	85	/r	data 8	3/10	3/14									
WAIT	Performs an NOP	9B	-	-	-	-	-	-	-	-	-	-	-	-	-

Table 94. Instruction Set Summary (Continued)

Instruction		Opcode - Hex			Clock Cycles		Flags Affected								
Mnemonic	Description	Byte 1	Byte 2	Bytes 3-6	IA186EM	IA188EM	O	D	I	T	S	Z	A	P	C
XCHG	Exchange word reg with AX	90	-	-	3	3	-	-	-	-	-	-	-	-	-
	Exchange AX with word reg	+rw	-	-	3	3									
	Exchange byte reg with r/byte	86 /r	-	-	4/17	4/17									
	Exchange r/m8 with byte reg		-	-	4/17	4/17									
	Exchange word reg with r/m16	87 /r	-	-	4/17	4/21									
	Exchange r/m16 with word reg		-	-	4/17	4/21									
XLAT	Set AL to memory byte segment :[BX+unsigned AL]	D7	-	-	11	15	-	-	-	-	-	-	-	-	-
XLATB	Set AL to memory byte DS :[BX+unsigned AL]	D7	-	-	11	15									
XOR	XOR imm8 with AL	34	ib	-	3	3	0	-	-	-	R	R	U	R	0
	XOR imm16 with AX	35	iw	-	4	4									
	XOR imm8 with r/m8	80	/6 ib	-	4/16	4/16									
	XOR imm16 with r/m16	81	/6 iw	-	4/16	4/20									
	XOR sign-extended imm8 with r/m16	83	/6 ib	-	4/16	4/20									
	XOR byte reg with r/m8	30	/r	-	3/10	3/10									
	XOR word reg with r/m16	31	/r	-	3/10	3/14									
	XOR r/m8 with byte reg	32	/r	-	3/10	3/10									
	XOR r/m16 with word reg	33	/r	-	3/10	3/14									

7.1 Key to Abbreviations Used in Instruction Set Summary Table

Abbreviations used in the [Instruction Set Summary Table](#) are explained below.

7.1.1 Operand Address Byte

The operand address byte is configured as shown below.

7	6	5	4	3	2	1	0
mod field		aux field			r/m field		

7.1.2 Modifier Field

The modifier field is defined below.

mod	Description
11	r/m is treated as a register field
00	DISP = 0, disp-low and disp-high are absent, address displacement is 0
01	DISP = disp-low sign-extended to 16-bits, disp-high is absent
10	DISP = disp-high:disp-low

7.1.3 Auxiliary Field

The Auxiliary Field is defined below.

aux	If mod = 11 and word = 0	If mod = 11 and word = 1
000	AL	AX
001	CL	CX
010	DL	DX
011	BL	BX
100	AH	SP
101	CH	BP
110	DH	SI
111	BH	DI

Note: When mod \neq 11, depends on instruction.

7.1.4 r/m Field

The r/m field is defined below.

r/m	Description
000	EA = (BX) + (SI) + DISP [where EA is the Effective Address]
001	EA = (BX) + (DI) + DISP
010	EA = (BP) + (SI) + DISP
011	EA = (BX) + (DI) + DISP
100	EA = (SI) + DISP
101	EA = (DI) + DISP
110	EA = (BP) + DISP [except if mod = 00, then EA = disp-high:disp-low]
111	EA = (BX) + DISP

7.1.5 Displacement

The displacement is an 8- or 16-bit value added to the offset portion of the address.

7.1.6 Immediate Bytes

The immediate bytes consist of up to 16 bits of immediate data.

7.1.7 Segment Override Prefix

The segment override prefix is configured as shown below.

7	6	5	4	3	2	1	0
0	0	1	SR	SR	1	1	0

7.1.8 Segment Register

The segment register is shown below.

SR	Segment Register
00	ES
01	CS
10	SS
11	DS

7.2 Explanation of Notation Used in Instruction Set Summary Table

Notation used in the [Instruction Set Summary Table](#) is explained below.

Parameter	Indication
:	The component of the left is the segment for a component located in memory. The component on the right is the offset.
::	The component of the left is concatenated with the component on the right.

Operand	Definition
imm8	Immediate byte: signed number between -128 and 127
imm16	Immediate word: signed number between -32768 and 32767
m	Operand in memory
m8	Byte string in memory pointed to by DS:SI or ES:DI
m16	Word string in memory pointed to by DS:SI or ES:DI
r/m8	General byte register or a byte in memory
r/m16	General word register or a word in memory

7.2.1 Opcode

Opcode parameters and definitions are provided below.

Parameter	Definition
/0 - /7	The Auxiliary Field in the Operand Address byte specifies an extension (from 000 to 111, i.e., 0 to 7) to the opcode instead of a register. Thus, the opcode for adding (AND) an immediate byte to a general byte register or a byte in memory is “80 /4 ib.” This indicates that the second byte of the opcode is “mod 100 r/m.”
/r	The Auxiliary Field in the Operand Address byte specifies a register rather than an opcode extension. The opcode byte specifies which register, either byte size or word size, is assigned as in the aux code above.
/sr	This byte is placed before the instruction as shown in Section 7.1.7, Segment Override Prefix .
cb	The byte following the Opcode byte specifies the offset.
cd	The double word following the Opcode byte specifies the offset and is some cases a segment.
ib	Immediate byte—signed or unsigned determined by the Opcode byte.
iw	Immediate word—signed or unsigned determined by the Opcode byte.
rw	Word register operand as determined by the Opcode byte, aux field.

7.2.2 Flags Affected After Instruction

Flags affected after instruction are shown below.

U	Undefined
-	Unchanged
R	Result-dependent

8. Innovasic/AMD Part Number Cross-Reference Tables

Tables 95 and 96 show Innovasic part numbers cross-referenced with the corresponding AMD part number.

Table 95. Innovasic/AMD Part Number Cross-Reference for the TQFP

Innovasic Part Number	AMD Part Number	Package Type	Temperature Grade
IA186EM-PTQ100I-R-03 lead free (RoHS-compliant)	AM186EM-20VC\W AM186EM-25VC\W AM186EM-33VC\W AM186EM-40VC\W AM186EM-20V\W AM186EM-25V\W AM186EM-33V\W AM186EM-40V\W	100-Pin Thin Quad Flat Package (TQFP)	Industrial
IA188EM-PTQ100I-R-03 lead free (RoHS-compliant)	AM188EM-20VC\W AM188EM-25VC\W AM188EM-33VC\W AM188EM-40VC\W AM188EM-20V\W AM188EM-25V\W AM188EM-33V\W AM188EM-40V\W		

Table 96. Innovasic/AMD Part Number Cross-Reference for the PQFP

Innovasic Part Number	AMD Part Number	Package Type	Temperature Grade
IA186EM-PQF100I-R-03 lead free (RoHS-compliant)	AM186EM-20KC\W	100-Pin Plastic Quad Flat Package (PQFP)	Industrial
	AM186EM-25KC\W		
	AM186EM-33KC\W		
	AM186EM-40KC\W		
	AM186EM-20KI\W		
	AM186EM-25KI\W		
	AM186EM-33KI\W		
	AM186EM-40KI\W		
IA188EM-PQF100I-R-03 lead free (RoHS-compliant)	AM188EM-20KC\W		
	AM188EM-25KC\W		
	AM188EM-33KC\W		
	AM188EM-40KC\W		
	AM188EM-20KI\W		
	AM188EM-25KI\W		
	AM188EM-33KI\W		
	AM188EM-40KI\W		

9. Errata

The following errata are associated with Version 03 of the IA186EM/IA188EM. A workaround to the identified problem has been provided where possible.

9.1 Errata Summary

Table 97 presents a summary of errata.

Table 97. Summary of Errata

Errata No.	Problem	Ver. 03
1	There is a difference in how priority of timer interrupts are asserted between the original AMD part and the Innovasic part.	Exists
2	Lock up just after reset is released.	Exists
3	Intermittent startup.	Exists
4	Timer Operation in continuous mode.	Exists
5	DMA interrupt will not bring device out of halt state.	Exists
6	Does not clear the interrupt request bit for INT0 upon entering the ISR.	Exists
7	There is a difference in how hardware handshaking for UARTs during a bus hold cycle is handled between the original AMD part and the Innovasic part.	Exists

9.2 Errata Detail

Errata No. 1

Problem: There is a difference in how priority of timer interrupts are asserted between the original AMD part and the Innovasic part.

Description: In the original AMD part, timer interrupts cannot be interrupted by another timer interrupt, even if the new timer interrupt is of a higher priority. The Innovasic part will interrupt a timer interrupt with a higher-priority timer interrupt. Additionally, if a lower-priority timer interrupt is interrupted with a higher-priority timer interrupt and another incident of the lower-priority interrupt occurs during the processing of the higher-priority interrupt, upon execution of the EOI, a new lower-priority interrupt will be initiated, possibly orphaning the original lower-priority timer interrupt.

Workaround: When using nested interrupts, at the beginning of the interrupt routine before the global interrupts are enabled with a CLI, timer interrupts must be specifically masked. At the

end of the timer interrupt routine being serviced, set the Interrupt Enable Bit in the Process Status Word to globally disable interrupts prior to clearing the timer interrupt being serviced and unmask the appropriate timer interrupts.

Errata No. 2

Problem: Lock up just after reset is released.

Description: Usually the first instruction is a long jump to the start of the user's code. In this case, the compiler apparently inserted a short jump instruction with zero displacement before the expected long jump instruction. The OEM device stuttered, but recovered to execute the long jump, while the device instruction pointer was corrupted, causing the lockup. In summary, a short jump with zero displacement is a corner case that does not work in the device.

Workaround: Do not use a short jump instruction with zero displacement.

Errata No. 3

Problem: Intermittent startup.

Description: Processor either came out of reset normally, or would go into a series of watchdog timeouts. The addition of 10K ohm pullups to the wr_n and rd_n outputs seemed to solve the issue. Further analysis of the OEM device shows the presence of undocumented pullups on these pins, which will pull them high when the reset condition tristates these pins. The device does not include internal pullups on these pins allowing these outputs to float during reset.

Workaround: Add 10K ohm pullups to wr_n and rd_n pins to guarantee proper logic levels at the end of reset.

Errata No. 4

Problem: Timer operation in continuous mode.

Description: The timers (Timer 0 and Timer 1) do not function per the specification when set in continuous mode with no external timer input stimulus to initiate/continue count.

Workaround: None.

Errata No. 5

Problem: DMA interrupt will not bring device out of halt state.

Description: When device is in halt state, the interrupt caused by a DMA completion will not bring the CPU out of the halt state.

Workaround: Use idle mode instead of halt.

Errata No. 6

Problem: Does not clear the interrupt request bit for INT0 upon entering the ISR.

Description: The interrupt bit for INT0 is not cleared until the interrupt routine is complete.

Workaround: Do not rely on the bit to be cleared when nesting interrupts.

Errata No. 7

Problem: How hardware handshaking for UARTs during a bus hold cycle is handled differently between the AMD part and the Innovasic part.

Description: In the AMD part, hardware handshaking works per the data sheet. The Innovasic part will occasionally drive a handshake signal to the incorrect state during bus hold instead of tristating the pin.

Workaround: None. Avoid using hardware handshaking in conjunction with the bus hold operation with the Innovasic part UARTs.

10. Revision History

Table 98 presents the sequence of revisions to document IA211050902.

Table 98. Revision History

Date	Revision	Description	Page(s)
August 17, 2005	13	Edition released.	NA
January 30, 2008	14	Errata 6 and 7 added.	130
February 19, 2008	15	Errata 7 clarified.	130
December 24, 2008	16	Document reformatted to meet publication standards. Added Conventions, Acronyms and Abbreviations , and Summary of Errata table .	All
July 15, 2009	17	Added V _{CC} parameters to Table 13.	42
January 25, 2010	18	Corrected PQFP Package Dimensions table	29
February 25, 2011	19	Updated section 2.2.46 to clarify that power is $\pm 10\%$; Removed package options to support the elimination of SnPb lead plating options	40, 140, 141

11. For Additional Information

The IA186EM/IA188EM is a form, fit, and function replacement for the original AMD Am186EM/188EM family of microcontrollers. Innovasic produces replacement ICs using its MILES system cloning technology that produces replacement ICs far more complex than “emulation” while ensuring they are compatible with the original IC. MILES captures the design of a clone so it can be produced even as silicon technology advances. MILES also verifies the clone against the original IC so that even the “undocumented features” are duplicated.

The IA186EM/IA188EM family of microcontrollers replaces obsolete AMD Am186EM/188EM devices, allowing customers to retain existing board designs, software compilers/assemblers, and emulation tools and thus avoid expensive redesign efforts.

The Innovasic Support Team wants its information to be complete, accurate, useful, and easy to understand. Please feel free to contact experts at Innovasic with suggestions, comments, or questions at any time.

Innovasic Support Team
3737 Princeton NE, Suite 130
Albuquerque, NM 87107 USA

Phone: +1-505-883-5263 (International)
Fax: (505) 883-5477
Toll Free: (888) 824-4184 (In US)
E-mail: support@innovasic.com
Website: <http://www.Innovasic.com>

Mouser Electronics

Authorized Distributor

Click to View Pricing, Inventory, Delivery & Lifecycle Information:

[Analog Devices Inc.:](#)

[IA188EMPTQ100IR03](#)